



*Please Check for  
CHANGE INFORMATION  
at the Rear of this Manual*

**4025  
COMPUTER DISPLAY  
TERMINAL**

**OPERATOR'S MANUAL**

**Tektronix, Inc.  
P.O. Box 500  
Beaverton, Oregon 97077**

**MANUAL PART NO.  
070-2401-02**

**First Printing NOV 1977  
Revised JUL 1981**

Copyright © 1977, 1978 by Tektronix, Inc., Beaverton, Oregon. Printed in the United States of America. All rights reserved. Contents of this publication may not be reproduced in any form without permission of Tektronix, Inc.

This instrument, in whole or in part, may be protected by one or more U.S. or foreign patents or patent applications. Information provided on request by Tektronix, Inc., P.O. Box 500, Beaverton, Oregon 97077.

TEKTRONIX is a registered trademark of Tektronix, Inc.

**WARNING**

This equipment generates, uses, and can radiate radio frequency energy and if not installed and used in accordance with the instruction manual, may cause interference to radio communications. It has been tested and found to comply with the limits for Class A computing devices pursuant to Subpart J of Part 15 of FCC Rules, which are designed to provide reasonable protection against such interference when operated in a commercial environment. Operation of this equipment in a residential area is likely to cause interference in which case the users at their own expense will be required to take whatever measures may be required to correct the interference.

# MANUAL REVISION STATUS

**PRODUCT:** 4025 Computer Display Terminal

This manual supports the following versions of this product: Serial No. B010100 & up

REV.	DATE	DESCRIPTION
@	NOV 1977	Original Issue
A	MAY 1978	Revised: pages i through vii, 1-1, 2-6, 3-8, 3-14 and 8-26.
B	JUL 1978	Revised: pages ii through vi and ix.
@	JUL 1978	Added: pages F-1 through F-11.
A,B,C	MAR 1979	Revised: pages 3-8, 5-18, 7-1, 7-5 , 8-15, 8-18, 8-27 and B-2.
@	AUG 1979	Added: pages C-5 through C-9.
A,B,C,D	AUG 1979	Revised pages.
A,B,C,D	SEP 1979	Revised: pages vii, viii, 1-3, 2-6, 2-9, 3-1, 3-3, 4-6, B-1, C-2, C-3, C-4, D-2, D-3, D-6.
A	OCT 1980	Revised: pages iii, 2-13, 3-11, 3-12, 3-18, 3-23, 3-24.
B	OCT 1980	Revised: pages 1-3 and D-3.



# CONTENTS

<b>Section 1</b>	<b>INTRODUCTION</b>	<b>Page</b>
	The 4025 .....	1-1
	Specifications.....	1-3
	Accessories.....	1-4
	The Split Screen: Monitor and Workspace .....	1-4
	Monitor.....	1-5
	Workspace .....	1-5
	Scrolling.....	1-6
	How the 4025 Might Be Used .....	1-6
	Dialing Up the Computer.....	1-6
	Logging In.....	1-7
	Initialization .....	1-7
	Retrieving a Record from the Host Computer.....	1-8
	Changing a Record.....	1-8
	Logging Off.....	1-9
<b>Section 2</b>	<b>OPERATOR CONTROLS</b>	
	Turning Power On .....	2-1
	The POWER Switch .....	2-1
	MASTER RESET Button.....	2-2
	The BRIGHTNESS and CONTRAST Controls.....	2-3
	How to Avoid Talking to the Computer .....	2-4
	The Keyboard.....	2-5
	ASCII Keys .....	2-6
	RETURN and LF .....	2-8
	SHIFT.....	2-9
	TTY LOCK .....	2-9
	BK SPC.....	2-9
	The Space Bar .....	2-10
	TAB.....	2-11
	BK TAB.....	2-11
	Control Characters and the CTRL Key .....	2-12
	ESC.....	2-12
	RUB OUT.....	2-13
	BREAK .....	2-13
	Cursor/Numeric Pad Keys .....	2-13
	Functioning as a Cursor Pad .....	2-13
	Functioning as a Numeric Pad.....	2-14

## Section 2 (cont)

	<b>Page</b>
Function Keys .....	2-15
ERASE .....	2-16
HOME .....	2-16
SEND .....	2-16
Editing Keys .....	2-17
TTY LOCK .....	2-18
NUMERIC LOCK .....	2-19
LEARN .....	2-19
COMMAND LOCKOUT .....	2-19
STATUS .....	2-20

## Section 3

### COMMANDS

Typing Commands on the Keyboard .....	3-1
The SYSTAT Message .....	3-3
The Workspace and the Monitor .....	3-5
Two Scrolls of Memory .....	3-5
Defining a Workspace .....	3-7
Directing Text to the Workspace or the Monitor .....	3-8
Erasing the Workspace or the Monitor .....	3-10
Form Fillout Mode .....	3-11
Keyboard Lock Mode .....	3-11
Sending Workspace Contents to the Computer .....	3-12
SYSTAT Fields Pertaining to the Split Screen .....	3-12
Margins and Tab Stops .....	3-13
Margins .....	3-13
Tab Stops .....	3-14
Buffered Operation .....	3-15
Sending Text From the Keyboard to the Computer .....	3-16
Sending the Workspace Contents .....	3-17
Entering Buffered Mode .....	3-17
Leaving Buffered Mode .....	3-18
Using the LEARN Key .....	3-18
Programming a Key .....	3-19
Making the 4025 "Forget" a Key Definition .....	3-20
The CLEAR Command .....	3-21
Selecting the Command Character .....	3-21
Setting the Communications Parameters .....	3-22
Baud Rates .....	3-22
Parity .....	3-23
Echo .....	3-24
End-of-Line String .....	3-25
Prompt String .....	3-26

<b>Section 4</b>	<b>OPERATING CONSIDERATIONS</b>	<b>Page</b>
	When You Turn the Power On.....	4-1
	Using the Workspace and the Monitor .....	4-2
	What to Do . . . . .	4-3
	If You Get a RESET or RAM ERROR Message.....	4-3
	RESET.....	4-3
	RAM ERROR .....	4-3
	If the Characters Typed Are Not Displayed Properly.....	4-4
	Displayed Not At All.....	4-4
	Displayed Twice.....	4-4
	Displayed in the Workspace When Typing into the Monitor.....	4-5
	If the 4025 Does Not Respond to Commands .....	4-5
	In Case of Difficulty .....	4-6
<b>Section 5</b>	<b>CREATING FORMS</b>	
	General Overview .....	5-2
	Basic Concepts .....	5-3
	Lines and Fields .....	5-3
	The Display List and Attribute Codes.....	5-4
	The ATTRIBUTE Command .....	5-6
	Syntax .....	5-7
	Visual Attributes .....	5-8
	Standard.....	5-8
	Enhanced .....	5-8
	Inverted.....	5-9
	Underlined .....	5-9
	Using More Than One Visual Attribute .....	5-10
	Blinking Between Visual Attributes .....	5-10
	Logical Attributes .....	5-11
	Alphanumeric .....	5-11
	Numeric.....	5-12
	Protected .....	5-12
	Modified .....	5-13
	Alternate Character Sets.....	5-14
	Rulings .....	5-15
	Drawing Rulings .....	5-16
	Getting the Junctions Right.....	5-17
<b>Section 6</b>	<b>GRAPHICS</b>	
	The GRAPHIC Command.....	6-1
	The VECTOR Command.....	6-3
	The ERASE G Command .....	6-4
	The LINE Command .....	6-4
	4010-Style Graphics Commands.....	6-5

<b>Section 7</b>	<b>MAKING HARD COPIES</b>	<b>Page</b>
	Copying on a 4631 Hard Copy Unit .....	7-1
	Copying on a Printer .....	7-5
<b>Section 8</b>	<b>PERIPHERAL DEVICES</b>	
	Printer .....	8-1
	Connecting the Printer to the 4025 .....	8-1
	Setting Switches on the 4642 .....	8-2
	Copying from the Workspace to the Printer .....	8-4
	Copying from the Host to the Printer .....	8-4
	End-of-File String .....	8-4
	Changing the End-of-File String .....	8-5
	The COPY Command .....	8-5
	Setting Printer Parameters .....	8-7
	GPIB Devices (4924 Tape Drive, 4662 Plotter) .....	8-8
	Introduction .....	8-8
	Power-On Procedure .....	8-8
	Initialization Procedure .....	8-11
	4924 Tape Drive .....	8-13
	Installing the 4924 .....	8-13
	Allocating Files .....	8-17
	The DIRECTORY Command .....	8-20
	The COPY Command: Copying to and from the Tape Drive ..	8-20
	/N and /U Switches .....	8-23
	The KILL Command .....	8-24
	4924 Error Messages .....	8-24
	4662 Plotter .....	8-25
	Installing the 4662 .....	8-26
	Operating Considerations .....	8-29
	Passing Commands to the Plotter .....	8-29
	Plotter Language Commands .....	8-30
	4025 Language Commands for the Plotter .....	8-32
	/P Switch .....	8-35
	The PASS Command .....	8-37
	Copying Data to and from the Host Computer .....	8-38
	End-of-File String .....	8-39
	Issuing a "Copy from Host Computer" Command .....	8-40
	The /D Switch .....	8-41



**Appendix A      EXAMPLES OF COMMANDS**

**Appendix B      THE ASCII CODE**

**Appendix C      OPTIONS**

**Appendix D      SPECIFICATIONS**

**Appendix E      PLOTTER COMMANDS**

**Appendix F      TESTING THE 4025**

**OPERATOR'S REFERENCE TABLE**

# ILLUSTRATIONS

Figure	Description	Page
1-1	4025 Computer Display Terminal .....	Frontis
1-2	The Split Screen Workspace and Monitor Scrolls .....	1-5
1-3	Example of a Form Displayed on the 4025's Screen .....	1-8
2-1	POWER, RESET, BRIGHTNESS and CONTRAST Controls.....	2-2
2-2	Keyboard .....	2-6
2-3	Status Message.....	2-21
3-1	SYSTAT Message .....	3-3
3-2	The Workspace and the Monitor.....	3-5
3-3	SYSTAT Indication of Form Fillout Mode.....	3-11
3-4	Parts of the SYSTAT Message Pertaining to the Workspace and the Monitor .....	3-13
3-5	SYSTAT Indication of Margin Settings.....	3-14
3-6	SYSTAT Indication of Tab Stops .....	3-15
3-7	Status Message.....	3-15
3-8	Buffered Operation .....	3-16
3-9	Key Definition Displayed in the Monitor.....	3-19
3-10	SYSTAT Indication of End-Of-Line String.....	3-25
5-1	The Parts of a Typical Form.....	5-3
5-2	Positions of Attribute Codes in a Display List.....	5-4
5-3	Effect of Field Attribute Codes .....	5-5
5-4	Parts of the ATTRIBUTE Command.....	5-7
5-5	Rulings Characters.....	5-18
6-1	A Graphics Area .....	6-2
6-2	Effect of a VECTOR Command .....	6-3
6-3	Line Types.....	6-5
7-1	4025 With 4631 Hard Copy Unit .....	7-2
7-2	Making a Copy of Text in the Workspace .....	7-3
8-1	Connections to printer .....	8-2
8-2	Switch settings on 4642 printer .....	8-3
8-3	PERIPHERALS message showing end-of-file string.....	8-5
8-4	4025 with GPIB peripheral devices .....	8-9
8-5	The PERIPHERALS list.....	8-10
8-6	GPIB interconnections.....	8-14
8-7	4924 rear panel switches .....	8-15
8-8	ALLOCATE command.....	8-17
8-9	Plotter switch positions and locations.....	8-27
8-10	Example of a plot in the workspace .....	8-35
C-1	United Kingdom Keyboard .....	C-2
C-2	French Keyboard.....	C-4
C-3	Swedish Keyboard .....	C-5

<b>Figure</b>	<b>Description</b>	<b>Page</b>
F-1	TEST display .....	F-2
F-2	Result of GTEST command .....	F-3
F-3	Connecting the Self Test Adapter .....	F-4
F-4	Function key lights during first part of test .....	F-5
F-5	Function key lights during second part of test .....	F-5
F-6	Order to press keys during keyboard test .....	F-7
F-7	Function key lights during third part of test .....	F-7
F-8	Function key lights during fourth part of test .....	F-8
F-9	Function key lights during fifth part of test .....	F-8
F-10	Display after part five of test .....	F-9
F-11	Function key lights during sixth part of test .....	F-9
F-12	Display after part six of test .....	F-9
F-13	CALIBRATE display .....	F-11

## TABLES

<b>Table</b>	<b>Description</b>	<b>Page</b>
8-1	Tape Drive Error Messages .....	8-24
8-2	Switch Settings for 4662 Plotter .....	8-27
8-3	Examples of 4662 Plotter Commands .....	8-30
B-1	ASCII Code Chart .....	B-0
B-2	Control Characters .....	B-3
C-1	United Kingdom Character Set .....	C-3
C-2	Swedish Character Set .....	C-6
D-1	Display Mechanism .....	D-1
D-2	Display Characteristics .....	D-2
D-3	Interface Characteristics .....	D-3
D-4	Buffering and Editing Capabilities .....	D-4
D-5	Keyboard Specifications .....	D-5
D-6	Graphics Specifications .....	D-6
D-7	Physical Characteristics .....	D-7
D-8	Power Requirements .....	D-8
E-1	Plotter Language Commands .....	E-1
E-2	Translation of Plotter Commands into 4025 Language .....	E-3



Fig. 1-1. 4025 Computer Display Terminal.

# Section 1

## INTRODUCTION

This manual provides an introduction to the TEKTRONIX 4025 Computer Display Terminal. It includes descriptions of the keyboard, the "workspace" and "monitor" areas of memory, and those commands which may be needed by a data entry or data retrieval operator. For a complete description of all the commands, see the Programmer's Reference Manual.

Appendix A gives examples of all the commands, including those not described in this manual.

### THE 4025

The TEKTRONIX 4025 Computer Display Terminal (Fig. 1-1) is an instrument that enables people to exchange information with computers. Inputs to the computer can be made by typing on the Terminal's keyboard, and data from the computer can be displayed on the Terminal's television-like screen.

The 4025 has the following features:

- *Buffered text.* Can hold a line of text (as many as 80 characters), allowing the line to be edited before being sent to the computer.
- *Local editing.* Can hold text in a workspace, where it can be edited before being sent to the computer.
- *Forms.* Holds forms in a workspace and allows the operator or the computer to fill in the blanks.
- *Visual enhancements.* Displays forms with visual enhancements, such as blinking underlines or bright backgrounds.
- *Definable keys.* Learns new definitions for most of the keys of its keyboard. The operator or the computer can assign any character or string of characters to a key. Thereafter, whenever that key is pressed, the 4025 interprets it as the defined character or string of characters. Commands, as well as text strings, may be included in these key definitions.
- *Repeating Keys.* Repeats any character when that character's key is depressed for longer than 1/2 second. Most function keys also repeat: of the 86 keys, 78 have the repeating feature.

## INTRODUCTION

- *Split screen.* Divides the screen into two areas when told to do so by the operator or the computer. The upper part of the screen displays the workspace, a scratchpad area for editing text or filling out forms. The lower part of the screen displays the monitor, where messages to and from the computer may be displayed without overwriting the text in the workspace.
- *Scrolling.* Scrolls text on the screen up and down. Text scrolled off the screen is not lost, but is saved as long as memory is available to hold it.
- *Programmable operating parameters.* Sets parameters such as baud rate and parity in response to commands from the computer or the operator. Remembers these settings even after power has been turned off.
- *Self test.* When the 4025 is turned on, it checks its memory and displays an error message if it has “forgotten” operating parameters or detects a memory defect. When commanded to do so, the 4025 can also check its firmware and display checksums and samples of all its characters.
- *Remotely programmable.* Changes its settings under computer control. Uses “English-language” commands, rather than non-printing control characters; this simplifies sending commands from the computer.
- *Detached keyboard.* Has a detached keyboard, which may be placed where convenient for the operator.

These additional capabilities are available as options:

- *Hard copies.* Makes copies on a TEKTRONIX 463I Hard Copy Unit. The copies can show anything displayed on the screen, including rulings characters and graphs. One or several pages of the display memory can be copied. Each hard copy page is about 8 1/2 by 11 inches in size and can show 53 lines of 80 characters each. (This is more than can be seen at once on the screen.)
- *Printed hard copies.* Prints copies on a TEKTRONIX 4642 Printer.
- *Rulings.* Draws vertical or horizontal single or double lines on forms in the workspace.
- *Alternate character sets.* Displays characters in the workspace using any of several fonts (character sets). Rulings characters, special math characters, and characters of different alphabets are available.

- *Graphics.* Displays graphs as part of a form or other text in the workspace. Can draw solid lines and several types of dashed lines, and can erase lines previously drawn.
- *International character sets.*

Also included in the graphics option is the ability to define new character sets: any characters the user desires.

- *Current loop interface.* Communicates with other devices using a 20 mA current loop, rather than the standard RS-232 interface.
- *Polling Interface.* Can be used in a polling environment, as one of several display stations communicating with the host computer through a polling controller.
- *Polling Controller.* Can hold a "polling controller", which supervises the communication of several terminals ("display stations") with the host computer. Communications with the host computer use IBM 3271/3277 Bisynchronous EBCDIC protocol.
- *GPIB Interface.* Communicates over a GPIB (General Purpose Interface Bus) with peripheral devices: TEKTRONIX 4924 Digital Cartridge Tape Drive and 4662 Interactive Digital Plotter.

## SPECIFICATIONS

Appendix D of this manual lists the 4025's specifications. Some of the more important specifications are:

- Transmission/reception speed of up to 9600 baud (about 960 characters/second). The following baud rates may be selected by command from the keyboard or the computer: 50, 75, 110, 134.5, 150, 300, 600, 1200, 1800, 2400, and 9600 baud. A baud rate of 0 is also provided for a "times 1" external clock (requires Option 1).
- Thirty-four lines of display, each holding up to 80 characters.
- Size of display memory: 4096 characters; may be expanded to 8192, 16384, or 32,768 characters (Options 20, 21, and 22).

## ACCESSORIES

The following standard accessories are provided with each 4025:

1 Operator's Manual	
1 Large (1x2) blank keycap	366-1748-00
1 Large (1x2) keycap cover	200-2163-00
4 Small (1x1) blank keycaps	366-1749-00
4 Small (1x1) keycap covers	200-2164-00
6 Keyboard overlays	334-3290-00

These optional accessories are also available:

Programmer's Reference Manual	
Reference Card	
Service Manual	
Keyboard overlay	334-3290-00
Large (1x2) blank keycap	366-1748-00
Large (1x2) keycap cover	200-2163-00
Small (1x1) blank keycap	366-1749-00
Small (1x1) keycap cover	200-2164-00

## THE SPLIT SCREEN: MONITOR AND WORKSPACE

You can divide the 4025's display into two different work areas, or *scrolls* of memory (Fig. 1-2). The bottom part of the screen displays the *monitor* scroll, while the top part displays the *workspace* scroll.

Text typed on the keyboard can be directed to either scroll, as can text coming from the host computer. When the keyboard types into the monitor, the cursor (an underline serving as a position marker) appears in the monitor. Likewise, when the keyboard types into the workspace, the cursor appears in the workspace.

The two scrolls each have specific uses. The workspace can hold text while it is being edited, or it can hold forms that are being filled out. The monitor provides a separate display area where messages to and from the computer may be displayed without overwriting the text in the workspace.



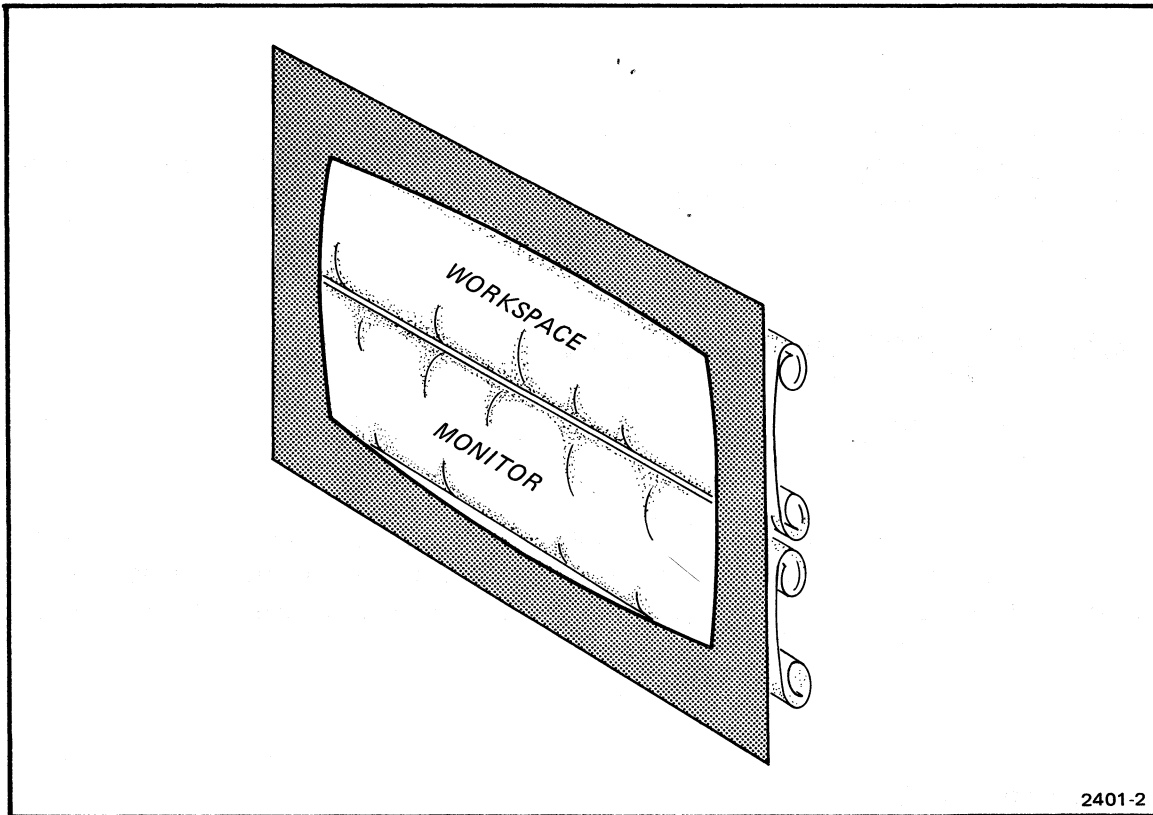

Fig. 1-2. The Split Screen: Workspace and Monitor Scrolls.

## Monitor

Text typed into the monitor is sent to the computer. When logging in on a time-sharing system, you would have both the keyboard and the computer send text to the monitor. (The monitor would then act like the roll of paper coming out of a teletypewriter.)

## Workspace

Text typed into the workspace is stored there and is not automatically sent to the computer. This lets you add or delete characters or lines with the special editing keys. When the text is as you like it, you can send the entire workspace contents to the computer.

The workspace can also hold a *form* whose blanks either you or the computer can fill in. With the 4025 in *form fillout mode*, you can fill in some or all of the form's blanks and then send the contents of those blanks to the computer.

### Scrolling

The two scrolls can each hold more text than is visible on the screen. Special scrolling keys allow you to roll the workspace and monitor scrolls up and down. When the keyboard types into the workspace (cursor in the workspace), the scrolling keys move the workspace scroll; when the keyboard types into the monitor, the scrolling keys affect the monitor scroll.

## HOW THE 4025 MIGHT BE USED

The following example shows one way the 4025 might be used. If you wish, you may skip this example and go on to Section 2.

In our example, let's assume that you work for the XYZ Company, which keeps a mailing list of its customers. Your job is to keep the list up-to-date by adding new names to the list, or by changing the entries when customers change their addresses. The list is kept in a disc file in the company's main computer. You use the 4025 to communicate with the computer.

### Dialing Up the Computer

Before you can make changes to the mailing list, you must first establish communication with the computer. You turn on the 4025 and place a telephone call using a special data telephone<sup>1</sup>. When the computer answers the phone, it puts an audio tone on the line. You then press a button on the data telephone to connect the 4025 to the computer.

At this point, the 4025 behaves like an ordinary teletypewriter. Whenever you type a character on the keyboard, the 4025 sends that character to the computer. The computer acknowledges that it has received the character by sending it back to the 4025. (This is called *echoing* the character). The echoed character is displayed on the 4025's screen<sup>2</sup>.

---

<sup>1</sup>In the XYZ Company, the computer is connected to its terminals over the ordinary telephone lines, and you must dial up the computer's telephone number in order to use it. This is not the case in all companies. In some computer installations, the terminals are always connected to the computer.

<sup>2</sup>This example assumes that the XYZ Company uses *full duplex, remote echo* data communication. It is possible to use the 4025 in other ways, such as *local echo*, in which the 4025 displays each character as it sends it to the computer, and the computer does not echo the character back to the 4025.

## Logging In

Now you must establish your authority to use the computer. You type a "login" message on the keyboard. The computer responds by asking for your password. If the password you type is correct, the computer sends a message acknowledging that you have "logged in" and have access to the computer.

## Initialization

Now you must gain access to the computer program that handles the mailing list. To do this, you type an instruction to the computer to run that program. The computer *initializes* the 4025 (sends a series of commands which prepare the 4025 for the task to come). These commands cause the 4025 to display a form on its screen (Fig. 1-3) and to direct characters typed on the keyboard into the blanks of that form. Also, the commands give special meanings to some of the keys:

- The SEND key is set so that pressing it sends to the computer what you have typed in the blanks of the form.
- Function Key 1 is set so that pressing it tells the computer to open a new entry in the mailing list.
- Function Key 2 is set so that pressing it makes the computer delete a mailing list entry.
- Function Key 3 is set so that pressing it tells the computer to stop running its "mailing list maintenance" program and log you off the computer.

At this point, you place an overlay around Function Keys 1 through 4. The overlay holds labels describing the functions of the keys.

Customer's Name	Tektronix, Inc.		
Street Address	Post Office Box 500		
City	Beaverton		
State	Oregon	Zip Code	97077

XYZ Company Mailing List Maintenance

2401-3

Fig. 1-3. Example of a form displayed on the 4025's screen.

### Retrieving a Record From the Host Computer

To retrieve a record from the computer's file, you type the customer's name in the first blank of the form and press the SEND key. The 4025 sends the name to the computer. The computer finds the customer's record and sends it back to the 4025, filling in the other blanks in the form displayed on the screen.

### Changing a Record

Once the record is received, any (or all) of the information can be changed, and new information can be added. Suppose that you have a new street address for that customer. By pressing the TAB key, you move through the form to the blank that holds the street address. You then type in the new address and press SEND again.

When you press SEND, the 4025 sends the computer only the part of the form that changed. That is, it sends the new street address, but does not repeat the customer's name, city, state, etc. When the computer receives the new street address, it corrects its mailing list.

After pressing SEND, you can erase the contents of the form (by pressing the ERASE key) and type in the next customer's name. You need not wait for the 4025 to finish sending the last customer's address.

**Logging Off**

When done making changes to the mailing list, you "log off" from the computer. In this example, you press Function Key 3. The computer then erases the 4025's screen and proceeds to log you off. As it does so, it sends a "logoff" message, which the 4025 displays for you to see.

You then end the call to the computer by replacing the handset in the special data telephone.



## Section 2

# OPERATOR CONTROLS

This section introduces you to the keys of the 4025's keyboard and to its other switches and controls. Exercises are included to help you become familiar with the 4025.

**CAUTION**

*Do Exercise 3 before doing any of the exercises which follow it. (Exercise 3 sets the 4025 so that you can practice on it without accidentally communicating with the computer.)*

*Should you put down this manual, be sure to do Exercise 3 before resuming your reading and doing any more exercises.*

## TURNING POWER ON

### The POWER Switch

The POWER switch is on the right side of the 4025's cabinet (Fig. 2-1); it has an internal lamp which lights when power is on.

When power is applied, the 4025 tests certain parts of its memory. Should the test reveal a failure, a RESET or RAM ERROR message will appear on the screen. (If that occurs, consult Section 4.)

**CAUTION**

*Do not place papers, books, etc. on the 4025's cabinet. Be especially careful not to cover the slits in the cabinet cover. These slits are needed to adequately ventilate the 4025's internal components.*

## OPERATOR CONTROLS

### MASTER RESET Button

The MASTER RESET button is next to the POWER switch. This button resets the 4025 to its "power up" condition; pressing it is like turning the 4025 off and then on again.

#### CAUTION

*If the 4025 contains information you wish to keep, do not operate the POWER switch or the MASTER RESET button. Doing so destroys any text or programmable key definitions you may have stored in the 4025.*

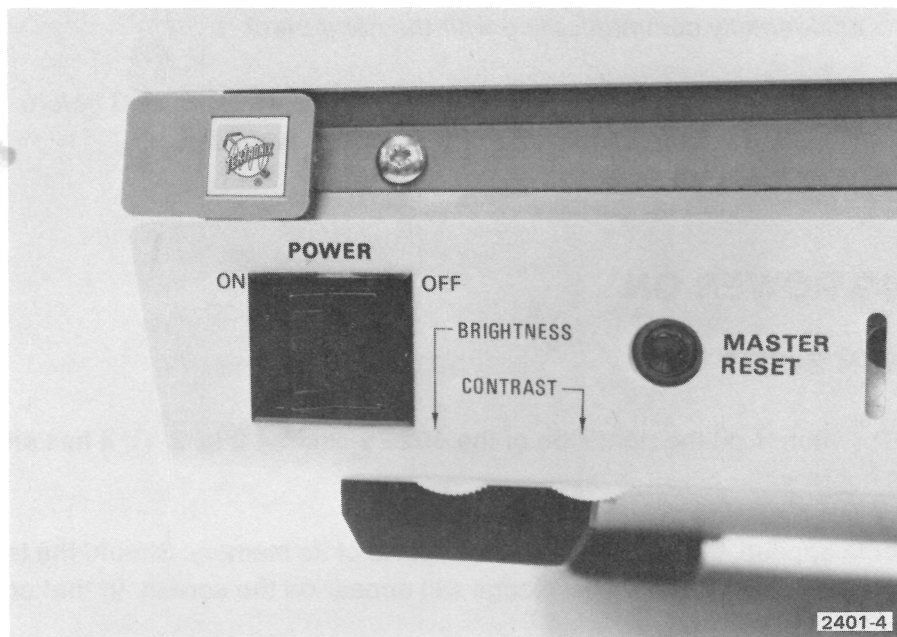

Fig. 2-1. POWER, MASTER RESET, BRIGHTNESS and CONTRAST controls.

#### NOTE

*In this manual, expressions such as "press SHIFT-STATUS", or "press CTRL-G" mean "while holding down the SHIFT key, press the STATUS key", or "while holding down the CTRL key, press the G key".*



Exercise 1

Turn on the **POWER** switch; its green light should turn on. After a delay of about 15 seconds, a cursor (underline) will appear in the upper left corner of the screen.

(Should a **RESET** message appear, consult Section 4 of this manual.)

Press **SHIFT-STATUS**; the *status message* should appear on the screen. (Do not touch any other keyboard keys yet, as you may inadvertently send data to the computer.)

Press the **MASTER RESET** button. The screen will erase and the cursor will appear in the upper left corner of the screen, just as it did when you first applied power.

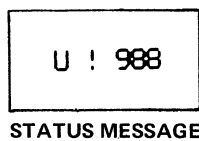
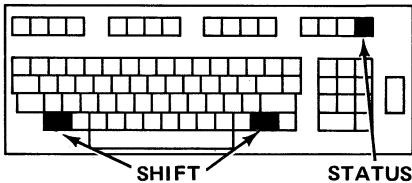

After applying power or pressing **MASTER RESET**, there is a delay of about 15 seconds before the cursor appears. During this time, the 4025 is testing its memory. Should the test reveal that essential settings like baud rate and parity have been forgotten, a **RESET** message will appear. (In that case, refer to Section 4.)

Should a **RAM ERROR** message appear, call your Tektronix Service Center; there is a defect in the 4025's memory.

**The BRIGHTNESS and CONTRAST Controls**

The **BRIGHTNESS** and **CONTRAST** controls are located near the **POWER** switch (Fig. 2-1). They function like the brightness and contrast controls of a television set: **BRIGHTNESS** adjusts the background brightness of the display, and **CONTRAST** adjusts the degree of contrast between the light and dark parts of the display.

Exercise 2

Press **SHIFT-STATUS**. The status message will appear on the screen. (Do not touch any other keys yet; doing so may send data to the computer.) Experiment with the **BRIGHTNESS** and **CONTRAST** controls, adjusting them until the display pleases you.

## HOW TO AVOID TALKING TO THE COMPUTER

It is sometimes possible to "confuse" a computer by sending improper data to it. The following discussion shows how to prevent this, by directing text from the keyboard to the 4025's internal workspace rather than to the computer.

If your terminal is always connected directly to the computer (constantly *on line*), use the following procedure to avoid talking to the computer:

1. Press **SHIFT-STATUS**. The 4025 will display the status message. Notice the second character displayed in this message: this is the command character, which you must type whenever you type commands to the 4025.
2. Check to be sure that the light on the **COMMAND LOCKOUT** key is off. If the light is on, press the key once to turn it off.
3. Now type the command character. Immediately after it, type the command **WORKSPACE 15 K** and press the **RETURN** key.

For instance, if the command character is the exclamation point (!), you type:<sup>1</sup>

```
!WORKSPACE 15 K <CR>
```

---

<sup>1</sup>In these examples, and throughout this manual, the **RETURN** key is denoted by **<CR>**. Also, in most examples, we shall assume that the command character is the exclamation point (!).

4. After the screen erases, a cursor (underline) appears in the upper left corner of the screen. You may now type on the 4025's keyboard without sending information to the computer.

**Exercise 3**

**Perform the procedure just described. That is, examine the short-form status message to learn the command character. Then check that the **COMMAND LOCKOUT** light is off and, after typing the command character, give the **WORKSPACE 15 K** command.**

(This command defines a *workspace*, allots 15 lines of the screen to displaying the workspace, and causes characters typed on the keyboard to be stored in the workspace rather than sent directly to the computer. The workspace, and the **WORKSPACE 15 K** command, are described in Section 3, under "The Workspace and the Monitor".)

## **THE KEYBOARD**

The 4025's keyboard is shown in Fig. 2-2. Its keys fall into three main categories:

- *ASCII keys.* The ASCII keys are used to send data to the computer. (We call them "ASCII keys" because they send characters of the ASCII code--the American Standard Code for Information Interchange. This code is described in Appendix B.)
- *Cursor/numeric pad keys.* The keys of the cursor/numeric pad serve two functions:
  - When the pad acts as a cursor pad, some of its keys move the cursor on the screen, and others scroll text in view up and down. \*
  - When the pad acts as a numeric pad, its keys are used to enter numeric data.

## OPERATOR CONTROLS

- *Function Keys.* The function keys control the 4025, causing it to erase text from its memory, insert or delete characters or lines of text, and so on. Many of these keys have no predefined meanings; they are reserved for programming by the user (or the computer).

### NOTE

*If you have Option 4A, 4B, or 4C, refer to Appendix C for optional keyboard configuration.*

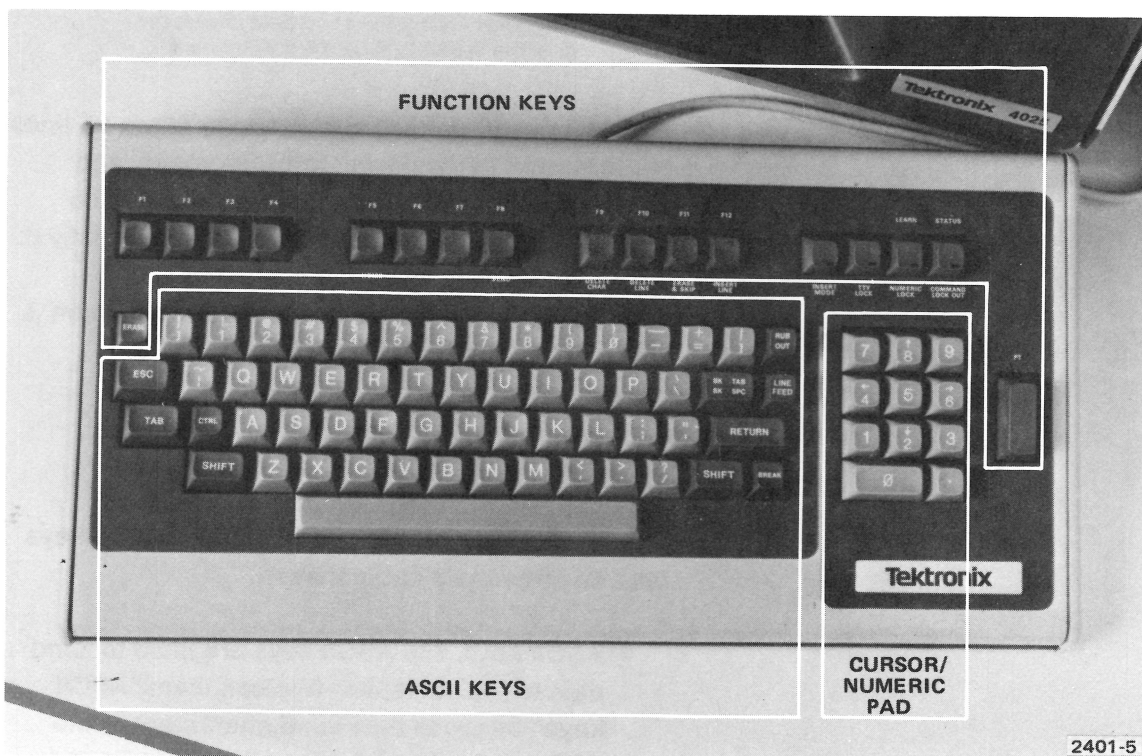

Fig. 2-2. Keyboard.

### ASCII Keys



The main part of the 4025's keyboard, which holds the ASCII keys, resembles an ordinary typewriter keyboard. However, there are some important differences. The easiest way to learn about these is to experiment with the keyboard. To guide you in this experimentation, this manual includes exercises to try.

**Exercise 4**

**(Be sure that you have done Exercise 3 first.)**

**Type a few words of some test sentence. Then press the RETURN key.**

As you type, the cursor moves to the right. (The cursor is an underline which serves as a position marker.) The cursor always indicates where the next character you type will be displayed.

The distinction between the ASCII keys and the 4025's other keys is important when you are communicating directly with the computer by typing on the keyboard:

- As you press an ASCII key, the 4025 sends a character to the computer. Thus, if you move the cursor by pressing RETURN, LF, or BK SPAC (which are ASCII keys), the computer is informed that you have moved the cursor.
- On the other hand, if you move the cursor with the cursor control keys (which are not ASCII keys), no characters are sent to the computer. Therefore, the computer is not informed that the cursor has moved.

The ASCII keys fall into three categories: alphanumeric keys, keys for non-alphanumeric characters, and the BREAK key. (While the BREAK key does not actually send an ASCII character, it does communicate with the computer by sending a *break* signal. Therefore, it is convenient to discuss it together with the ASCII keys.)

The alphanumeric keys, colored light gray, send the "printing" ASCII characters to the computer. These represent letters, numerals, and special symbols. ("Space" is considered a printing character.)

## OPERATOR CONTROLS

The non-alphanumeric keys, colored dark gray, send certain of the special “non-printing” ASCII characters. These include the rub out (or delete) character, and the escape, horizontal tab, back-space, carriage return, and line feed characters. Also included among the non-alphanumeric keys are the SHIFT and CTRL keys, which help select the characters sent when alphanumeric keys are pressed.

### RETURN and LF

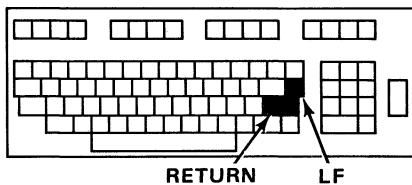

The RETURN and LF keys send the *carriage return* and *line feed* ASCII characters. *Carriage return* returns the cursor to the left edge of the screen, and *line feed* advances the cursor to the following line.

#### Exercise 5

Type a few words of text; do not press RETURN. Then press LF a few times and watch the cursor move down the screen.

Type a few more lines, pressing RETURN at the end of each line.

#### NOTE

*When communicating with a computer, the characters sent when you press RETURN may differ as required by the system. However, the net visual response will be the same: pressing RETURN moves the cursor to the start of the next line.*

**SHIFT**

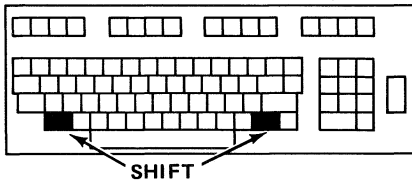

Most of the 4025's keys have two meanings: the *normal* and *shifted* meanings. For instance, pressing the Q key while holding down SHIFT sends the uppercase letter (Q); pressing the same key without SHIFT sends the lowercase letter (q). Function keys, as well as other keys, have shifted meanings: SHIFT-HOME is not the same as HOME.

**TTY LOCK**

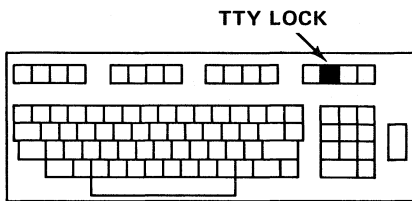

The 4025 does not have a shift lock key like that on a typewriter. Instead, it has the TTY LOCK function key. Pressing TTY LOCK lights the light on that key and locks the keyboard so that it cannot send lowercase letters of the alphabet. (TTY LOCK does not affect the action of the other keys.) Pressing TTY LOCK again unlocks the keyboard and turns off the TTY LOCK light. An advantage of TTY LOCK is that you can type numerals on the alphanumeric keys with TTY LOCK active, whereas a shift lock key would not permit this. (You should use the TTY LOCK key when using computers or computer programs that do not accept lowercase letters.)

**Exercise 6**

**Press TTY LOCK; the light in that key will turn on. Type a few words, and notice that they are displayed in all uppercase letters. Then press TTY LOCK again, and type a few more words, using lowercase letters.**

**BK SPC**

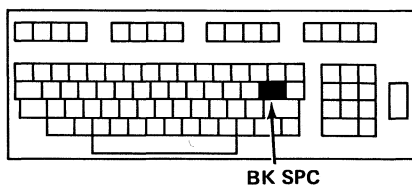

The BK SPC (backspace) key sends the *backspace* ASCII character. This moves the cursor backwards (to the left) one character position.

## OPERATOR CONTROLS

### Exercise 7

Type a few words and then use **BK SPC** to move the cursor back to the beginning of the line. Repeat this several times, typing over the words which you have previously typed.

Notice that as you type over characters already displayed on a line, the characters typed replace characters formerly on the line. This provides an easy way to change text in the workspace.

### The Space Bar

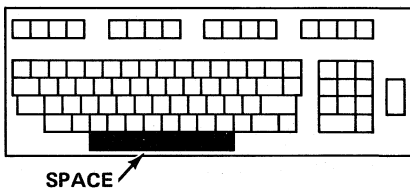

The space bar sends the ASCII *space* character. The 4025 and the computer treat *space* just like any other letter of the alphabet. For instance, when you type over previously entered characters with the space bar, those characters are replaced with spaces.

This means that you cannot use the space bar just to move across the page, as you would the space bar of a typewriter. To move the cursor without entering or changing text, you must use the cursor control keys, discussed later in this section.

### Exercise 8

Type a few words of text. Use **BK SPC** to move the cursor back to the beginning of the line. Then hold the space bar down; notice that as the cursor moves to the right, characters previously on the line are erased (replaced with spaces).



**TAB**

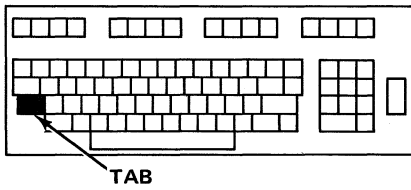

The TAB key sends the *tab* character of the ASCII code.

When you are typing into the 4025's workspace rather than directly to the computer, TAB moves the cursor to the next tab stop, or to the beginning of the next line if there are no tab stops defined to the right of the cursor. If you are filling in the blanks of a form (4025 in "form fillout mode"), TAB moves the cursor to the next blank in the form.

When you are typing from the keyboard directly to the computer, you should avoid using TAB unless you know how the computer will respond to that character.

**BK TAB**

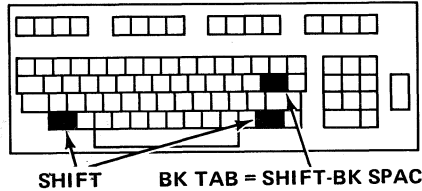

When SHIFT is held down, the BK SPC key becomes the BK TAB (backtab) key.

When you are typing into the 4025's workspace rather than directly to the computer, BK TAB moves the cursor to the previous tab stop in a line, or to the beginning of the line if there are no tab stops to the left of the cursor. If you are filling in the blanks of a form (4025 in "form fillout mode"), BK TAB moves the cursor to the preceding blank of the form.

When you are typing from the keyboard directly to the computer, BK TAB moves the cursor to the preceding tab stop in a line, but does not send any character to the computer. (There is no *backtab* character in the ASCII code.) Thus, BK TAB serves only to move the cursor; it sends no information to the computer.

## OPERATOR CONTROLS

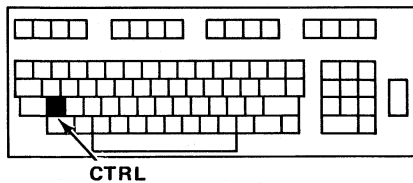

### Control Characters and the CTRL Key

The ASCII alphabet includes a number of *control* characters which have special meanings. For instance, *carriage return* and *line feed* are control characters; so are *bell* and *form feed*. Only a few of the control characters have their own keys on the keyboard: the RETURN, LF, BK SPC, TAB, ESC, and RUB OUT keys.

By means of the CTRL key, however, you can send any of the control characters. To do this, hold down CTRL while typing another key. For each control character there is a key which, when pressed while holding CTRL down, sends that control character.

For instance, CTRL together with G sends the *bell* character, CTRL-M sends *carriage return*, and CTRL-J sends *line feed*.

#### Exercise 9

**Hold down the CTRL key and type the letter G. Then, while holding down CTRL, type J.**

CTRL-G sends the *bell* character, ringing the 4025's bell. CTRL-J sends *line feed*, moving the cursor down one line. Table B-2 in Appendix B lists the ASCII control characters with the keys to press to send those characters.

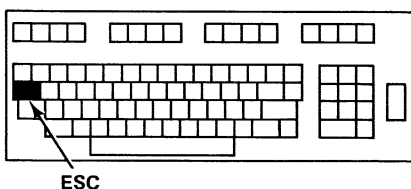

**ESC.** When you are typing from the 4025's keyboard directly to the computer, the ESC key sends the ASCII *escape* character. *Escape* is one of the non-printing control characters of the ASCII code.

When typing into the 4025's workspace rather than directly to the computer, ESC has no effect.

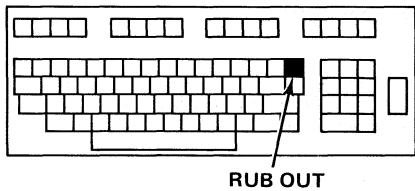

**RUB OUT.** The RUB OUT key sends another special ASCII character, the *rub out* or *delete* character. Like ESC, RUB OUT has no effect when typing into the workspace.

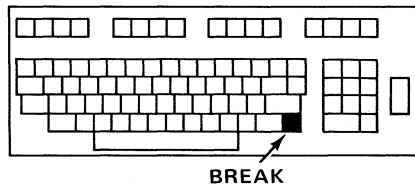

**BREAK.** The BREAK key is occasionally used to interrupt the host computer, but should be used with caution. (Consult your computer systems analyst to learn when to use BREAK.) To use this key to interrupt the computer, press it twice in quick succession.

You can also use the BREAK key to remove the 4025 from its buffered mode of operation. This is described in Section 3, under "Buffered Operation".

**BREAK (Firmware Versions 1.6 and 2.2 Only).**

The Break key is occasionally used to interrupt the host computer, but should be used with caution. (Consult your computer systems analyst to learn when to use BREAK.) One press of the BREAK key transmits a TDATA break time of 350 msec.

You can also use the BREAK key to remove the terminal from buffered mode, to clear the input and output buffers, to exit keyboard lock, and to terminate various peripheral operations. These functions require that the BREAK key be pressed twice in quick succession.

**Cursor/Numeric Pad Keys**

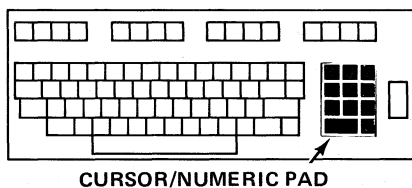

The *cursor/numeric pad* consists of the eleven light gray keys located to the right of the ASCII keys. They can be used in two ways: as a *cursor pad* and as a *numeric pad*.

**Functioning as a Cursor Pad**

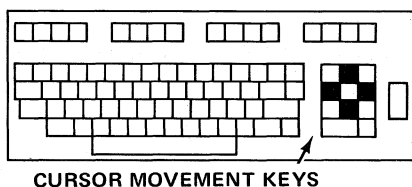

When the light on the NUMERIC LOCK key is off, the pad acts as a cursor pad. The four keys marked with arrows move the cursor in the direction of the arrows.

## OPERATOR CONTROLS

### Exercise 10

Check that the light on the **NUMERIC LOCK** key is off. (If the light is on, press **NUMERIC LOCK** once to turn it off.) Then experiment with the cursor control keys, moving the cursor about on the screen.

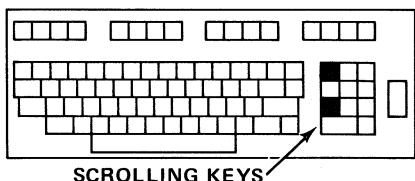

The two keys with triangular markings scroll the text in the workspace up and down. (If the keyboard is typing into the monitor, rather than the workspace, these keys move the monitor scroll rather than the workspace scroll.)

### Exercise 11

Type several lines of text, until the display scrolls upward to accommodate the text you have entered. You now have enough text in the workspace to use the scrolling keys. Type several more lines of text, and then use the scrolling keys to move the text up and down.

### NOTE

*The scrolling keys will not move the workspace or monitor scrolls past the end of the text already in memory. Thus, if the entire text is in view, the scrolling keys will have no effect. (For this purpose, "text in memory" includes any empty lines that may have been inserted by moving the cursor below the end of the scroll.)*

### Functioning as a Numeric Pad

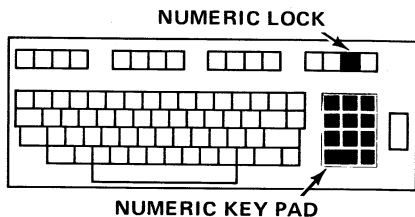

To use the keypad to enter numeric data, press the **NUMERIC LOCK** key; the light on that key will turn on. To return the pad to its cursor control functions, press **NUMERIC LOCK** again; the light will turn off. With **NUMERIC LOCK** on, you can use the pad as a numeric keypad; its keys send ASCII characters for the numeric digits. With **NUMERIC LOCK** off, the keys do not send anything to the computer, they only move the cursor.

Exercise 12

Press **NUMERIC LOCK**, and use the numeric pad to type several numbers. Then press **NUMERIC LOCK** again, and use it to move the cursor.

You can move the cursor even when the pad is a functioning as a numeric pad (**NUMERIC LOCK** on). To do this, hold **SHIFT** down; the shifted versions of the pad keys still function to move the cursor and to scroll text up and down.

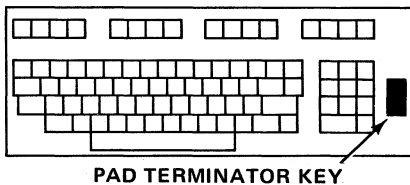

The pad terminator function key (labeled "PT") is just to the right of the cursor/numeric pad. Pressing this key has no effect unless you or the computer has assigned a meaning to it. (This is done with the **LEARN** key, discussed in Section 3.)

For instance, you might use a *space* to separate numbers to be entered. In that case, you would program the PT key to mean *space*. After entering each number, you would press the pad terminator key to type a *space* before entering the next number.

(Alternatively, after entering each number, you might want to give a **SEND MOD** command, as described in Section 3. In that case, PT would be programmed to give the **SEND MOD** command.)

**Function Keys**

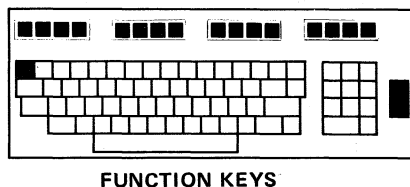

The function keys control the 4025, causing it to erase the screen, display the status message, insert characters, etc. These keys do not necessarily send ASCII characters to the computer, although most of them can be programmed to do so.

Some of the function keys have no labels describing their functions. These are reserved for you or the computer to program with the **LEARN** key or the **LEARN** command. (The **LEARN** key is described in Section 3. For the **LEARN** command, see the Programmer's Reference Manual.)

## OPERATOR CONTROLS

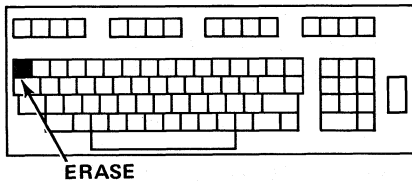

### ERASE

The ERASE key erases the scroll (workspace or monitor) into which the keyboard is typing. (The workspace and monitor are described in Section 3.) If you are typing into the workspace, the entire workspace is erased. (This includes any text that may be scrolled up out of view.) Similarly, if you are typing into the monitor, ERASE clears the entire monitor.

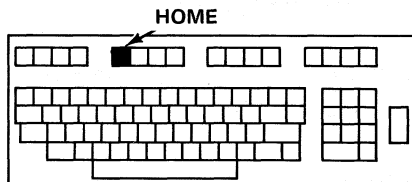

### HOME

The HOME key moves the cursor back to the beginning of the workspace or the monitor, rewinding the workspace or monitor scroll if necessary. If you are typing into the workspace, the cursor moves to the beginning of the workspace. Likewise, if you are typing into the monitor, HOME moves the cursor to the beginning of the monitor.

#### Exercise 13

**Press HOME, and see the cursor move back to the start of the workspace. Then press ERASE to clear the workspace.**

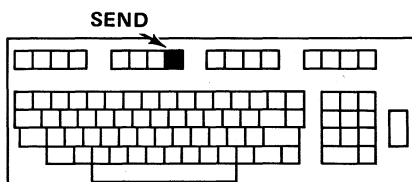

### SEND

When it has been suitably programmed, you can use the SEND key to give the SEND ALL or SEND MOD commands. The SEND ALL command sends the entire contents of the workspace to the host computer, while the SEND MOD command sends only certain parts of the workspace to the computer. (For more information on these commands, see "Sending Workspace Contents to the Computer", in Section 3 of this manual.)

NOTE

Unlike the other labeled function keys, the SEND key performs no function until the 4025 has LEARNed a meaning for it.

Editing Keys

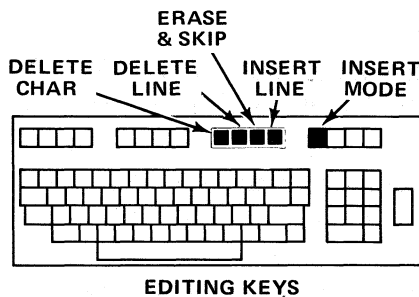

Five of the function keys are used for editing text in the 4025's memory.<sup>2</sup> These are the DELETE CHAR, DELETE LINE, ERASE & SKIP, INSERT LINE, and INSERT MODE keys.

The DELETE CHAR key deletes the character at the cursor position from the text on the screen. Characters to the right of the cursor move left to fill the gap.

The DELETE LINE key deletes the entire line in which the cursor is located. Lines below it move up to fill the gap left by the deleted line.

The ERASE & SKIP key deletes the characters from the cursor position to the end of the line. The cursor moves to the start of the next line.

The INSERT LINE key inserts a blank line below the present cursor position and moves the cursor to the beginning of that line.

The INSERT MODE key lets you insert characters into a line. When you press INSERT MODE, a light on that key turns on. While the light is on, any characters typed are inserted in the line at the present position of the cursor. Characters at or to the right of the cursor move right to make room for the inserted characters. (If any of these characters move right off the end of the line, they are lost.) Pressing the key again removes the 4025 from "insert mode" and turns off the INSERT MODE light.

<sup>2</sup>You can edit text typed into the workspace, and then later send that text to the computer with the SEND ALL or SEND MOD command, as described in Section 3.

## OPERATOR CONTROLS

### Exercise 14

**Type some text, and then experiment with the DELETE CHAR, DELETE LINE, ERASE & SKIP, INSERT LINE, and INSERT MODE keys. You will find these keys quite useful for editing text.**

Ordinarily, you would use the editing keys only when typing into the workspace, as you have been doing in this section's exercises.

You should not use the editing keys when typing text from the keyboard directly to the computer. This is because the editing keys only affect the display in the 4025, and do not send information to the computer. Consequently, if you try to use the editing keys to change text already typed in the monitor and sent to the computer, you won't accomplish the desired result. Although the 4025's display of the text will be edited, the text already sent to the computer won't be.

An exception to this occurs when the 4025 is operating in buffered mode, described in Section 3. In buffered mode, you can use the editing keys to edit each line of text typed in the monitor, but only before you press RETURN. Once you press RETURN, that line of text is beyond recall.

### TTY LOCK

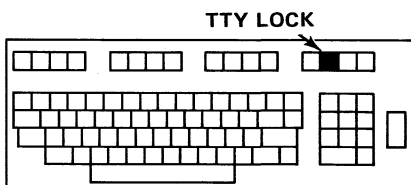

The TTY LOCK key has already been mentioned in connection with the ASCII keys. It is used with those keys much like a typewriter's shift lock key. Pressing this key lights a light on the key and locks the keyboard so that it cannot send lowercase letters of the alphabet. (The corresponding uppercase letters are sent instead.) Pressing the key again unlocks the keyboard and turns off the light.



**NUMERIC LOCK**

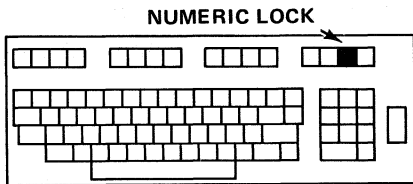

The NUMERIC LOCK key has already been mentioned in connection with the cursor/numeric pad. Pressing this key lights the light on the key and lets the cursor/numeric pad function as a numeric pad for entering numbers. Pressing the key again turns off the light and returns the pad to its usual cursor movement function.

**LEARN**

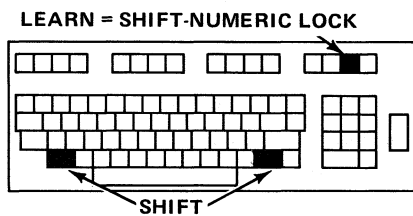

The LEARN KEY is the shifted version of the NUMERIC LOCK key. It is discussed in Section 3, under "Using the LEARN Key".

**COMMAND LOCKOUT**

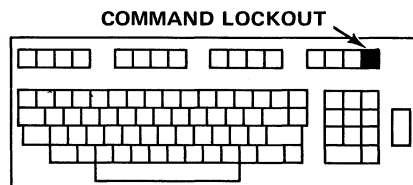

The COMMAND LOCKOUT key is the rightmost of the four lighted function keys. Pressing this key turns on the light on the key and causes the 4025 to ignore the command character which signals the start of a command. (The command character is described in Section 3, under "Typing Commands on the Keyboard".) With COMMAND LOCKOUT active, the 4025 will not respond to commands typed on the keyboard or received from the computer. Pressing the key again turns off the light and enables the 4025 to respond to commands.

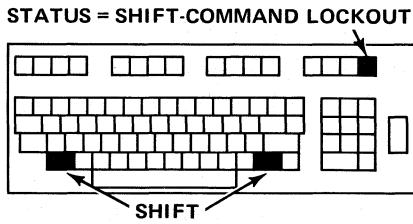

**STATUS**

The STATUS key is the shifted version of the COMMAND LOCKOUT key. Use this key to examine the *status message*. (Fig. 2-3.)

**Exercise 15**

**While holding down SHIFT, press STATUS. A *status message* will appear.**

The status message has three parts:

- The first part is a single letter, either U (for “unbuffered”) or B (for “buffered”). This indicates whether the 4025 is operating in *buffered mode*.<sup>3</sup>
- The second part of the short-form status message is a single character. This is the command character, which you must use to give the 4025 most of its commands.

**NOTE**

*If the command character is one of the non-printing ASCII characters (such as escape, for instance), a two-letter mnemonic for the character appears in the status message. Table B-2 in Appendix B shows the two-letter mnemonic for each ASCII control character.*

- The third part of the status message shows the number of blocks of memory left in the 4025. (Each block contains 16 words of memory, and may hold from 7 to 14 characters of text.)

<sup>3</sup>Buffered mode is described in Section 3 of this manual.

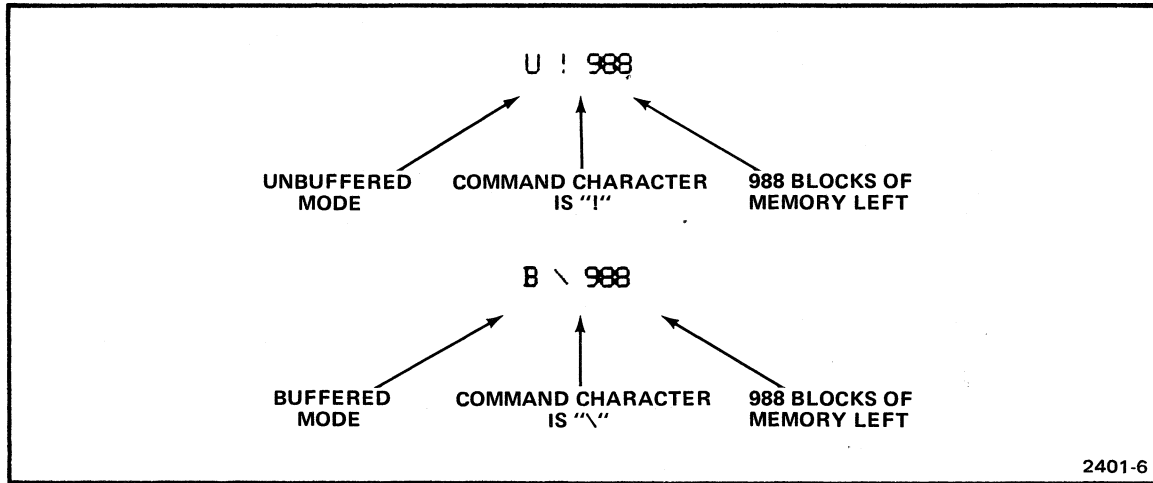

Fig. 2-3. Status message.



# Section 3

## COMMANDS

This section describes some of the commands which you can give the 4025. Not all the commands are discussed; for more information, see the 4025 Programmer's Reference Manual. Also, Appendix A gives examples of all commands, including those not described in this manual. These are the topics in this section:

- Typing commands on the keyboard.
- Interpreting the SYSTAT message.
- Using the two scrolls (workspace and monitor) which the 4025 displays on its screen.
- Setting margins and tab stops.
- Buffered operation.
- Making the 4025 "learn" new meanings for its keyboard keys; and making it "forget" what it has "learned".
- Selecting a different command character.
- Setting the communications parameters: baud rate, parity, etc.

### TYPING COMMANDS ON THE KEYBOARD

You can give a few commands to the 4025 by just pressing keys such as ERASE or HOME. Most commands, however, must be typed on the keyboard or sent from the computer.

Before typing a command, be sure the COMMAND LOCKOUT light is off. (If the light is on, the 4025 will not respond to the commands you type, although it will respond to keys like ERASE and HOME.) If the light is on, press the key once to turn it off.

To type a command, begin by typing the command character. (See the discussion of the STATUS key in Section 2.) This notifies the 4025 that a command is to follow. The 4025 responds by moving the cursor to the monitor (if it is not already there) and displaying the command character.

## COMMANDS

Type the command **immediately** after the command character, with no intervening spaces. Each command starts with a *keyword* - the name of the command. For instance, to set the tab stops, you type the keyword STOPS. (If you wish, you may abbreviate any keyword by typing only its first three letters.)

### NOTE

*If you misspell the keyword, or otherwise mistype the command, the 4025 will display an error message. (It will display "WHAT?" and the mistyped command.) If this happens, type the command again correctly.*

Follow the keyword with a space, and then type any *parameters* which the command may require. (Parameters are additional numbers or letters which give the 4025 more details about what you want it to do.) Separate the parameters from the keyword with a space, and from each other with commas or spaces. After typing the parameters, if any, end the command by pressing RETURN.

Suppose, for instance, that the command character is the exclamation point(!), and that you want to make hard copies of two pages of the text in the workspace. You would type:

!HCOPY 2 WORKSPACE <CR> or !HCO 2 W <CR>

(In this example, "2" and "W" are parameters for the HCOPY command. This command is described in Section 7.)

If the command character were the ampersand (&) and you wanted to erase the monitor, you would type:

&ERASE MONITOR <CR> or &ERA M <CR>

## THE "SYSTAT" MESSAGE

The 4025's system status message, or *SYSTAT* message, tells you almost everything you may need to know about the 4025's status. You should examine this message after changing any of the 4025's settings. If you ever become confused about the 4025's operation, examining the *SYSTAT* message may help you understand what is happening.

On the last page of this manual (RT-1), there is a table in which you should record the *SYSTAT* settings for your particular computer installation.

To see the *SYSTAT* message, type:

```
!SYSTAT <CR> or !SYS <CR>
```

```
TB= 2400 RB= 2400 DL= 0 LM= 1 RM=70 WL=20 V#=1.1
TS= 5 8 12 26 0 0 0 0 0 0 0 0 0 0 0 0
CC=! FS=9 PR=? EL=9
DU=F BU=N EC=R FF=N SN=N KB=M CM=W PA=N
```

2401-7

Fig. 3-1. The *SYSTAT* message.

The following "translation" interprets the message shown in Fig. 3-1. Some of the settings will be explained later in this manual, and many are of interest only to the person who programs the computer to talk to the 4025. (See the Programmer's Reference Manual for more information about these settings.)

**TB= 2400 RB= 2400**

The transmitting and receiving baud rates are each set to 2400 baud.

**DL= 0** The delay before the 4025 responds to a prompt from the host computer is set to 0 milliseconds.

**LM= 1 RM=70**

The workspace's left margin is set at column 1, and the right margin at column 70.

## COMMANDS

- WL=20** The visible workspace length is set to 20 lines. That is, 20 lines of the screen are used to display the workspace, and the remainder (14 lines) to display the monitor.
- V# = 1.1** This 4025 has firmware version 1.1 installed.
- TS= 5 8 12 26 0 0 0 0 0 0 0 0 0 0 0**  
The tab stops are set at columns 5, 8, 12, and 26.
- CC=!** The command character is the exclamation point (!).
- FS=↵** The field separator is *carriage return*.
- PR=?** The prompt string consists of a single character, the question mark (?).
- EL=↵** The end-of-line string consists of a single character, *carriage return*.
- DJ=F** The 4025 is set for full duplex data communications.
- BU=N** The 4025 is not in buffered mode.
- EC=R** The 4025 is set for remote echo rather than local echo.
- FF=N** The 4025 is not in form fillout mode.
- SN=N** The 4025 is not in snoopy mode.
- KB=M** Text coming from the keyboard is directed to the monitor.
- CM=W** Text from the computer is directed to the workspace.
- PA=N** No parity checking is being done.

### NOTE

*There may be additional information in the SYSTAT message, beyond that shown in this example, if the 4025 is equipped with certain options.*



## THE WORKSPACE AND THE MONITOR

### Two Scrolls of Memory

Think of the 4025's display memory as consisting of two *scrolls* (Fig. 3-2). The screen displays part of each scroll, but not the entire scroll.

The reason for having two scrolls is this: you can use one scroll to hold the text or form on which you are working, and the other to display your communications with the computer. That way, messages from the computer are not written over your text or form.

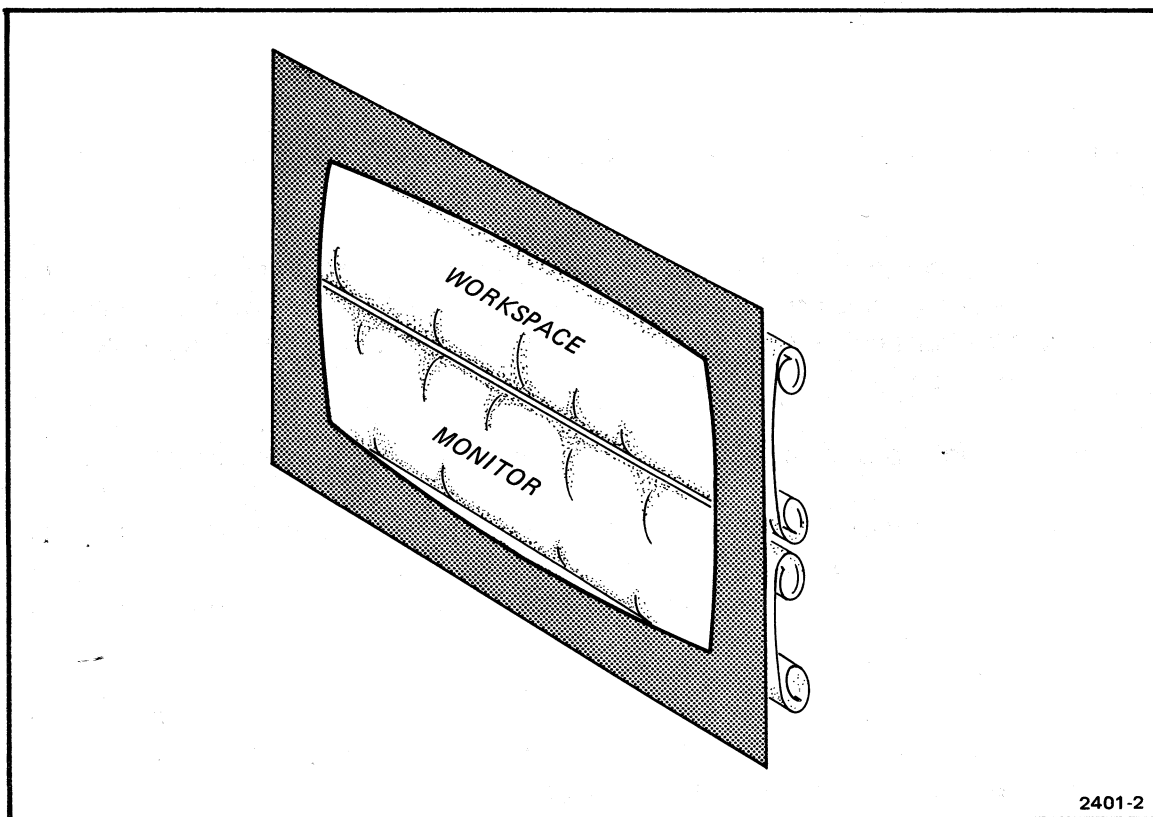

Fig. 3-2. The workspace and the monitor.

## COMMANDS

The bottom scroll is the *monitor*. (When the 4025 is first turned on, the monitor occupies the entire screen; there is no top scroll.) The monitor has two uses:

1. The monitor displays conversations that you have with the 4025. For instance, whenever you type a command to the 4025, that command is displayed in the monitor. Similarly, if the 4025 does not understand the command, it displays an error message in the monitor. When you press SHIFT-STATUS or give a SYSTAT command, the status or SYSTAT message appears in the monitor.
2. You can use the monitor to display conversations between you and the host computer. When you use the 4025 this way, it behaves like an ordinary teletypewriter; the monitor scroll imitates the roll of paper on which a teletypewriter prints.

The top scroll is the *workspace*. The workspace has many features which the monitor lacks:

- Text typed into the workspace is not immediately sent to the computer, but instead is held until you command the 4025 to send that text. This allows you to edit the text, perhaps deleting or adding characters or lines to get it just right before sending it on to the computer.
- In the workspace (but not the monitor), you can set right and left margins.
- The workspace can hold a form with blanks which either you or the computer can fill. With the 4025 operating in form fillout mode, you can send to the computer the contents of all the blanks in the form, or of only those blanks whose contents have been modified.
- In creating a form, you can make the 4025 emphasize certain parts of the text by displaying them with distinguishing *visual attributes*, such as *inverted* or *enhanced* backgrounds or blinking underlines.
- If your 4025 has the optional rulings characters (Option 32), you can draw vertical and horizontal lines in the workspace to create forms.
- With other optional character sets installed, the workspace can display other special characters, such as "math" characters (Option 34).
- If your 4025 has the graphics option, you (or the computer) can draw pictures in the workspace, with solid lines or a variety of dashed lines. Also, you can define your own alternate character sets, and so display (in the workspace) any special characters you may desire.

## Defining a Workspace

When the 4025 is first turned on, the monitor occupies the entire screen; no workspace exists. Before you can use a workspace, you (or the computer) must create that workspace. This is called *defining a workspace*, and it is done with the WORKSPACE command or the MONITOR command.

More precisely, when you define a workspace, you do two things:

- You cause the 4025 to separate its display memory into two parts: the workspace and monitor scrolls.
- You tell the 4025 the number of lines of the screen to use for displaying the workspace scroll, and the number of lines to use to display the monitor scroll.

The 4025's screen can display 34 lines of text. In defining a workspace, you can either tell the 4025 how many lines to use for the workspace, or you can tell it how many to use for the monitor.

- You can use a WORKSPACE command to tell the 4025 how many lines of the screen to use for displaying the workspace. The 4025 will then use the remaining lines to display the monitor.
- You can use the MONITOR command to designate how many lines to use for displaying the monitor. The 4025 will then use the remaining lines to display the workspace.



**CAUTION**

*Whenever a workspace is defined (or redefined), the contents of the monitor and the workspace (if already defined) are lost. Therefore, you should define a workspace only at the start of your work.*

To create a workspace and reserve the top 30 lines of the screen for displaying it (leaving the bottom 4 lines for the monitor), type:

```
!WORKSPACE 30 <CR> or !WOR 30 <CR>
```

## COMMANDS

To reserve the bottom 5 lines of the display for the monitor and leave the remaining 29 lines above it for the workspace, type:

```
!MONITOR 5 <CR> or !MON 5 <CR>
```

The parameter in a WORKSPACE command may be any number from 0 to 33; in a MONITOR command, it may be any number from 1 to 34. (There are 34 lines in the display, at least one of which must be reserved for the monitor.)

### Directing Text to the Workspace or the Monitor

Text entered from the keyboard can go to either the workspace or the monitor, as can text coming over the communications line from the host computer. Use the WORKSPACE and MONITOR commands to tell the 4025 where to put text coming from the keyboard or the computer.

Characters typed on the keyboard fall into two categories:

- **Conversational communications** between you and the 4025 are always displayed in the monitor. That is, when you type a command, the command appears in the monitor. Also, when you use the LEARN key, described later in this section, a *key definition* is displayed in the monitor.
- **Text** (everything but commands and key definitions) typed on the keyboard can go to either the workspace or the monitor. To send text from the keyboard to the workspace, type:

```
!WOR <CR> or !WOR K <CR>
```

(The "K" stands for "keyboard".)

To send text from the keyboard to the monitor, type:

```
!MON <CR> or !MON K <CR>
```

#### NOTE

After typing the !MON or !MON K commands, you may find that the characters you type are not displayed. Should this occur, type:

```
!Echo L <cr>
```

This command is described later in this section.

Characters coming over the communications line from the host computer also fall into two categories:

- **Commands** from the computer are executed, but not displayed.
- **Text** (everything but commands) from the computer can go to either the workspace or the monitor.

To direct text from the computer to the workspace, type:

`!WORKSPACE H <CR>` or `!WOR H <CR>`

(The "H" stands for "host computer".)

To direct text from the computer to the monitor, type:

`!MONITOR H <CR>` or `!MON H <CR>`

It is possible in one `WORKSPACE` or `MONITOR` command to define a workspace and direct text to it or to the monitor. For instance:

`!WOR 15 H K <CR>`

creates a workspace, allots the top 15 lines of the screen to it, and directs text from the computer and from the keyboard to that workspace.

**Exercise**

Type a `WORKSPACE 20 H K` command, and then examine the `SYSTAT` message. You should see "`WL=20`", "`KB=W`", and "`CM=W`".

```
TB= 2400 RB= 2400 DL=   0 LM= 1 RM=70 WL=20 V#=1.1
TS= 5  8 12 26 0  0  0  0  0  0  0  0  0  0  0  0
CC=! FS=6 PR=? EL=6
DU=F BU=N EC=R FF=N SN=N KB=W CM=W PA=N
```

## COMMANDS

Then type a **MONITOR 30 H** command, and examine the **SYSTAT** message again. You should have "WL=4". (With 30 lines taken for the monitor, only the top four lines of the screen will display the workspace.) The keyboard will still type into the workspace ("KB=W"), but the computer will now type into the monitor ("CM=M").

```
TB= 2400 RB= 2400 DL= 0 LM= 1 RM=70 WL= 4 V#=1.1
TS= 5 8 12 26 0 0 0 0 0 0 0 0 0 0 0 0
CC=! FS=6 PR=? EL=6
DU=F BU=N EC=R FF=N SN=N KB=W CM=M PA=N
```

When the 4025 is first turned on, or when MASTER RESET is pressed, there is no workspace defined ("WL=0" in the SYSTAT message), and both computer and keyboard send text to the monitor ("KB=M", "CM=M").

### Erasing the Workspace or the Monitor

One way to erase the contents of the workspace or the monitor is to press the ERASE key. Pressing this key erases the scroll (workspace or monitor) into which the keyboard is typing.

You can accomplish the same thing by typing:

```
!ERASE <CR> or !ERA <CR>
```

Suppose, however, that you are typing text into the workspace, but you want to erase the monitor rather than the workspace. To do this, designate the monitor in an ERASE command:

```
!ERASE MONITOR <CR> or !ERA M <CR>
```

Similarly, while typing into the monitor, you can erase the workspace by typing:

```
!ERASE WORKSPACE <CR> or !ERA W <CR>
```

Erasing the workspace or the monitor frees some of the 4025's memory for other uses.

## Form Fillout Mode

The 4025 has a *form fillout* mode of operation. In this mode, the workspace holds a prepared form, and either you or the computer can fill in the *blanks* of the form. Ways of using form fillout mode are summarized here; look in Section 5 to learn how to create a form in the workspace.

To see whether the 4025 is in form fillout mode, examine the SYSTAT message (Fig. 3-3). Look for the "FF=" part of the message: "FF=Y" means the 4025 is in form fillout mode, and "FF=N" means it is not.

```

TB= 2400 RB= 2400 DL=  0 LM= 1 RM=70 WL= 4 V#-1.1
TS= 5 8 12 26 0 0 0 0 0 0 0 0 0 0 0 0
CC=! FS=9 PR=? EL=9
DU=F BU=N EC=R FF=Y SN=N KB=M CM=M PA=N

```

2401-8

Fig. 3-3. SYSTAT indication of form-fillout mode.

These are the special features of form fillout mode:

- You can type only in the *blanks* of the form (the *unprotected fields*). If you try to type elsewhere, the bell sounds and the character typed is inserted in the next blank.
- The TAB key no longer moves the cursor to the next tab stop. Instead, it moves the cursor to the next blank of the form. Similarly, BK TAB moves the cursor back to the preceding blank.
- HOME moves the cursor to the start of the first blank, rather than to the start of the first line.
- ERASE doesn't erase the whole workspace, but just the data in the blanks of the form.
- Some of the blanks (the *numeric fields*) will accept numerals and special characters, but not letters of the alphabet.

## Keyboard Lock Mode

The Keyboard Lock Mode, normally controlled by the computer program, prevents unwanted data or command entry from the keyboard. The commands are:

!PAD 205 to lock the keyboard

!PAD 203 to unlock the keyboard (BREAK-BREAK from the keyboard will also unlock it)

## Sending Workspace Contents to the Computer

The SEND command sends the workspace contents to the computer. This command takes two forms: SEND ALL and SEND MOD. (If you leave out the word ALL or MOD, the 4025 interprets the command as a SEND ALL command.) These commands perform differently when the 4025 is in form fillout mode than when it is not.

**CAUTION**

*Use the SEND command (or the SEND key) only as required by the particular host computer program you are using.*

When the 4025 is **not** in form fillout mode, the SEND ALL and SEND MOD commands are treated alike. Each of these commands sends the entire contents of the workspace to the computer:

!SEND ALL or  
!SEND MOD

In form fillout mode, the SEND ALL and SEND MOD commands behave as follows:

SEND ALL. The SEND ALL command sends the contents of all the blanks in the form.

SEND MOD. The SEND MOD command sends the contents of only those blanks whose contents have been modified.<sup>1</sup>

## SYSTAT Fields Pertaining to the Split Screen

Fig. 3-4 illustrates the parts of the SYSTAT message which pertain to the workspace and the monitor. The SYSTAT message shows:

- The number of lines of the screen used to display the workspace.
- Whether the keyboard types into the workspace or the monitor.
- Whether text from the communications line is directed to the workspace or the monitor.

<sup>1</sup>It is, however, possible to designate other parts of the form (*protected fields*) as "modified", so that they, too, will be sent each time a SEND MOD command is executed. This is described in Section 5.



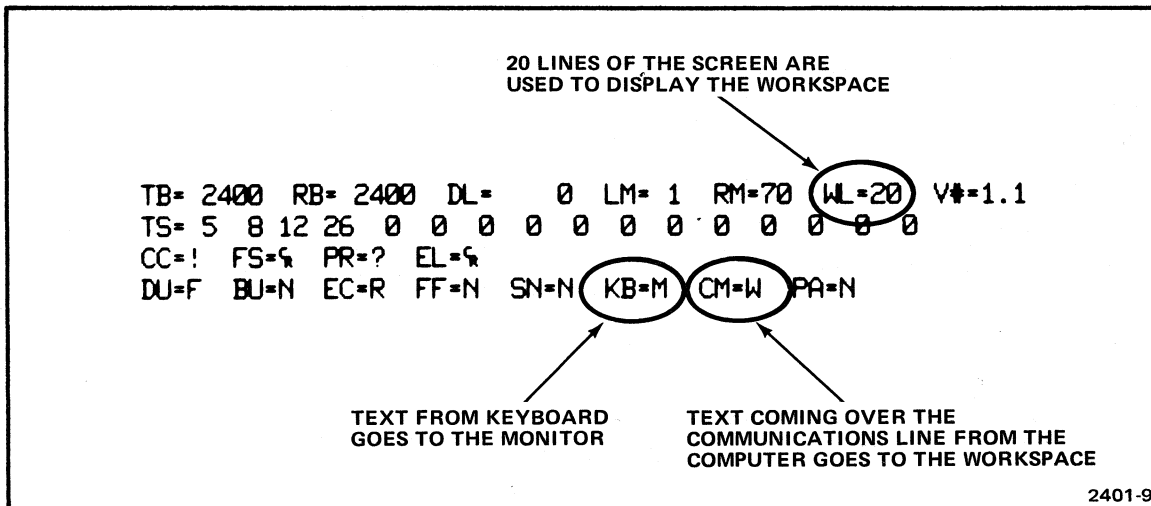

Fig. 3-4. Parts of the SYSTAT message pertaining to the workspace and the monitor.

## MARGINS AND TAB STOPS

Either you or the computer can set margins and tab stops in the workspace, similar to the margins and tab stops in a typewriter. (Margins affect only the workspace; the monitor has no margins.) There are eighty character positions (columns) in each line, and you can set the margins at any of these. You can define up to 16 tab stops, putting them in any of the columns except column 1.

### Margins

To set the margins at the extreme left and right edges of the screen, type this command:

!MARGINS <CR> or !MAR <CR>

To set the left margin at column 10 and the right margin at column 70, type this:

!MARGINS 10, 70 <CR> or !MAR 10, 70 <CR>

To change the setting of the left margin without disturbing the right margin, enter only one number in the command. For instance, to set the left margin at column 15 (leaving the right margin where it is) type:

!MARGINS 15 <CR>

## COMMANDS

You cannot type to the left of the left margin, but you can type beyond the right margin (right out to column 80). If you type in the column beyond the right margin, the bell sounds.

The "LM" and "RM" parts of the SYSTAT message (Fig. 3-5) give the current settings of the left and right margins. It is wise to examine the SYSTAT message to check that you have set the margins correctly.

```
TB= 2400 RB= 2400 DL= 0 LM= 1 RM=70 WL=20 V#=1.1
TS= 5 8 12 26 0 0 0 0 0 0 0 0 0 0 0 0 0 0 0 0
CC=! FS=␣ PR=? EL=␣
DU=F BU=N EC=R FF=N SN=N KB=M CM=W PA=N
```

2401-10

Fig. 3-5. SYSTAT indications of margin settings.

The 4025 remembers margin settings even after you turn off the power or press the MASTER RESET button.

### Tab Stops

The STOPS command sets the tab stops. For instance, to set tab stops in columns 10, 15, and 20; type:

```
!STOPS 10, 15, 20 <CR>
```

You may set up to 16 tab stops, in columns 2 to 80. When using the STOPS command, you should remember two things:

- You must list the column numbers in increasing order. For instance, you may type:

```
!STOPS 10,15,20 <CR>
```

However, you should not type:

```
!STOPS 15,10,20 <CR>
```

- Each time you use the STOPS command, you must list all columns where you want tab stops. If you leave any column numbers out, tab stops previously at those columns are deleted.

Fig. 3-6 shows how the SYSTAT message indicates where the tab stops are located. After setting the tab stops, check the SYSTAT message to be sure that you have set them correctly.

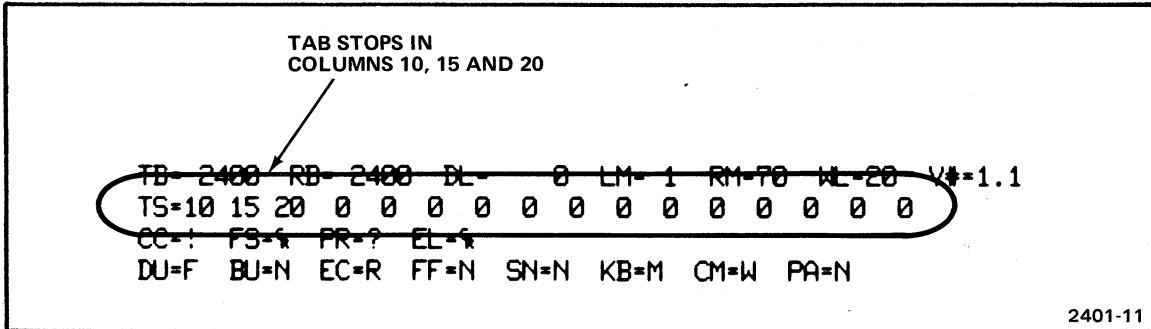

Fig. 3-6. SYSTAT indication of tab stops.

The 4025 remembers tab stop settings, like margin settings, even after it has been turned off or reset with the MASTER RESET button.

## BUFFERED OPERATION

The 4025 has a *buffered* mode of operation, in which it sends data to the computer only when the computer has requested that data.

To learn whether the 4025 is in buffered mode, press SHIFT-STATUS. The 4025 will display the status message (Fig. 3-7). The first character in this message is a B if the 4025 is in buffered mode, and a U if it is not.

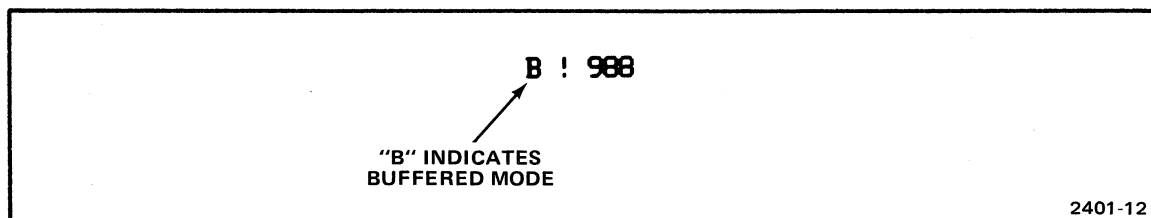

Fig. 3-7. Status message.

### Sending Text from the Keyboard to the Computer

Buffered operation differs from unbuffered operation in the way that text typed into the monitor is sent to the computer. In unbuffered mode, as you type into the monitor, the 4025 sends each character on to the computer as soon as you type it. In buffered mode, on the other hand, the 4025 does not send the characters right away. Instead, it holds each line of text and sends that line to the computer only after (a) you press RETURN to mark the end of the line, and, moreover, (b) the computer has asked for that line to be sent.

Fig. 3-8 illustrates buffered operation. As you type into the monitor, you can change a line of text any time before pressing RETURN. When you press RETURN, the 4025 copies that line into a part of its memory called the *transmit buffer*. You can continue to type in lines of text. As you press RETURN at the end of each line, that line is copied into the transmit buffer, where it waits its turn to be sent to the computer.

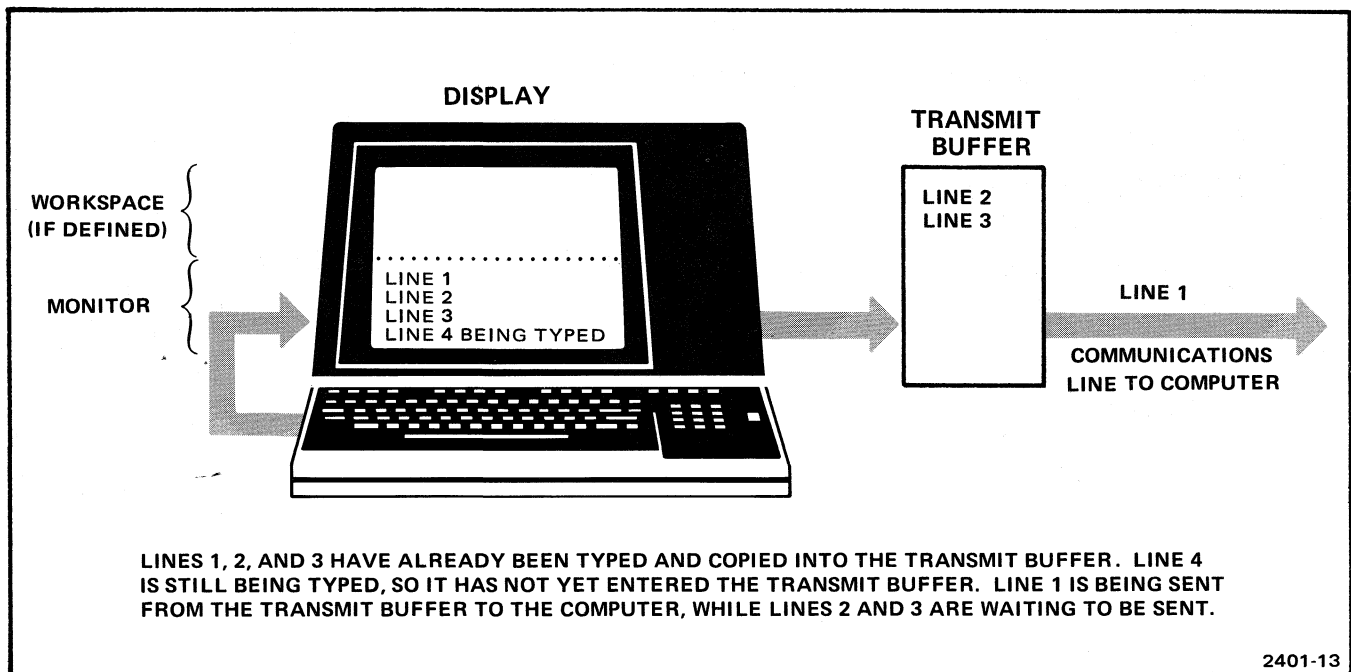

Fig. 3-8. Buffered Operation.

The 4025 sends lines of text from the transmit buffer one at a time, in order. If you type several lines of text, the computer must make several requests for data from the 4025. At each request, the 4025 sends one line of text.

**CAUTION**

*The 4025 will not go on to its next task (such as executing a command typed on the keyboard) until it has finished sending the contents of its transmit buffer. If the computer does not send the necessary prompts, the 4025 cannot go on to the next task.*

*If this happens, press BREAK twice in quick succession. This removes the 4025 from buffered mode and sends a break signal to interrupt the host computer.*

*If you ever encounter this difficulty, consult your computer systems analyst; there may be a fault in the computer's program.*

## **Sending the Workspace Contents**

Suppose the 4025 is in buffered mode, and you want to send the workspace contents to the computer. To do this, give a SEND ALL or SEND MOD command, either by typing the command, or by pressing the SEND key. (The SEND key must first be programmed to give the SEND ALL or SEND MOD command. This may be done by the computer or by means of the LEARN key, described later in this section.)

When the 4025 executes the SEND command, it copies the contents of the workspace into its transmit buffer and waits for the computer to request that each line be sent. When the computer has requested and received each line from the transmit buffer, the 4025 is ready for its next task.

## **Entering Buffered Mode**

When you first turn on the 4025, it powers up in unbuffered mode. To put it in buffered mode, type the BUFFERED or BUFFERED YES command. For instance, if the command character is the exclamation point (!), you would type:

!BUFFERED <CR> or !BUF <CR>

### Leaving Buffered Mode

There are four ways to remove the 4025 from buffered mode:

- The usual way to remove the 4025 from buffered mode is with the BUFFERED NO command. That is, to remove the 4025 from buffered mode, type:

```
!BUFFERED NO <CR> or !BUF N <CR>
```

When the 4025 has emptied its keyboard buffer, it will execute the BUFFERED NO command and return to unbuffered mode.

- Another way to exit buffered mode is to press the BREAK key twice in quick succession. (In addition to removing the 4025 from buffered mode, this sends a *break* signal to interrupt the computer.) You would use this method if the 4025 were not responding to commands because the host was not sending prompts. (Without the prompts, the 4025 could not empty its transmit buffer and go on to the next command.)
- Since the 4025 powers up in unbuffered mode, you can remove it from buffered mode by turning the power off, and then on again. This method is not recommended, as it destroys any text in the 4025's memory.
- Pressing MASTER RESET has the same effect as turning power off, and then on again. It also has the same disadvantages.

### USING THE LEARN KEY

You can assign a new meaning to almost any key on the keyboard. Defining a new meaning for a key is called *programming* that key, and it is done with the LEARN key. (The LEARN key is the shifted version of the NUMERIC LOCK function key.)

#### NOTE

*Anything the LEARN key can do can also be done by the computer with the LEARN command (described in the Programmer's Reference Manual). Since the computer ordinarily programs the function keys, you normally need not use the LEARN key.*

*Unless you need to program a key, you do not have to read the following explanation of the LEARN key.*

## Programming a Key

To program a key:

1. Press SHIFT-LEARN.
2. Press the key you want to program.
3. Press, in order, the keys whose meanings you want to assign to the key being programmed.
4. Press SHIFT-LEARN again.

As you program a key, the 4025 displays in the monitor the meaning (*key definition*) you are assigning to that key. Fig. 3-9 illustrates what would appear in the monitor if you assigned the meaning "This is a test" to the "{" key.

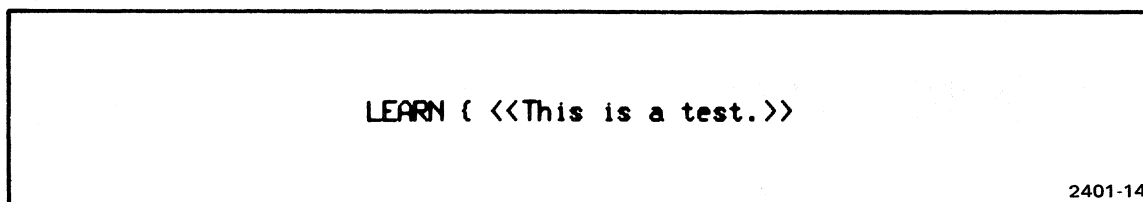

Fig. 3-9. Key definition displayed in the monitor.

### Exercise

Program the "{" key to mean, "This is a test". That is, press SHIFT-LEARN and type "{"; then type "T", "h", "i", etc., to spell "This is a test". Finally, press SHIFT-LEARN again.

As you do this, notice the message that appears in the monitor. First, as you press SHIFT-LEARN, the word LEARN appears. Then, as you press the key being programmed, the character for that key appears. (If the key has no ASCII character, a "blotch" - the "rubout" symbol - appears instead.) After displaying the character (or "blotch") for the key being programmed, the display shows two left angle brackets (<<). Next, as you press the keys whose meanings you are giving the key being programmed, the characters for those keys appear. Finally, as you press SHIFT-LEARN again, two right angle brackets (>>) appear.

Now try pressing the "{" key. Instead of the character "{", you see the message, "This is a test".

## COMMANDS

The shifted and unshifted versions of each key are programmed independently. For instance, when you programmed "{", you did not change the meaning of "[".

Every key that you press while programming a key will be interpreted as part of the key definition. Thus, you cannot use the cursor movement keys or editing keys in the usual way. If you make a mistake while programming a key, terminate the programming by pressing SHIFT-LEARN. Then start over again.

During a key definition you can press keys such as RETURN or LF if you wish; the corresponding ASCII characters will become part of the key definition. In fact, you can include any ASCII character in a key definition. (The control characters are represented in the monitor by two-letter mnemonics, such as CR for *carriage return*.) You can also incorporate function keys or cursor control keys in a key definition. These have no corresponding ASCII characters, so they are represented by "blotches" in the display.

The only keys you can't program, and can't incorporate into the programming of other keys, are:

- The rightmost three of the lighted function keys.
- CTRL, SHIFT, and BREAK.

### Making the 4025 "Forget" a Key Definition

To restore a key to its original meaning:

1. Press SHIFT-LEARN.
2. Press the key you wish to restore to its original meaning.
3. Press SHIFT-LEARN again.

#### Exercise

**Restore the "[" key to its original meaning. When you have done so, press "{" to check that it no longer means "This is a test".**



## The CLEAR Command

You can restore all the keys of the keyboard to their ordinary meanings by typing the CLEAR command. For instance, if the command character were the exclamation point, you would type:

```
!CLEAR <CR> or !CLE <CR>
```

## SELECTING THE COMMAND CHARACTER

Normally, you should leave the command character unchanged, so that the 4025 always responds to commands from the computer. The 4025 remembers its command character even after being turned off; it would only forget if the battery powering that part of its memory should fail. (In that case, a RESET message appears when you turn on the 4025.)

If you do get a RESET message, use the COMMAND command to reset the command character. For instance,

```
!COMMAND @ <CR> or !COM @ <CR>
```

changes the command character from “!” to “ @ ”.

To set the command character to one of the non-printing ASCII control characters, use the ASCII decimal equivalent for that character in the command. (Table B-1 in Appendix B gives ASCII decimal equivalents for all the ASCII characters.) For instance, the ASCII decimal equivalent for the *shift out* control character is 14, so

```
!COM 14 <CR>
```

changes the command character from “!” to *shift out*.



*When using the ASCII decimal equivalent to specify a control character in the COMMAND command, you must type the ASCII decimal equivalent as a two- or three-digit numeral. (A one-digit numeral is not interpreted as an ASCII decimal equivalent, but as a character itself.)*

*For instance, !COM 02 sets the command character to the start of heading character, whose ASCII decimal equivalent is 2; but !COM 2 sets the command character to the digit “2”.*

## SETTING THE COMMUNICATIONS PARAMETERS

To communicate successfully with the host computer, certain of the 4025's settings must agree with what the computer expects. For instance, if the 4025 transmits characters at 1200 baud (120 characters/second), and the computer expects to receive characters at 110 baud (about 10 characters/second), the computer will not understand what the 4025 is saying.

You should not normally have to set the communications parameters, since the 4025 remembers these settings even when its power is turned off. You should, however, keep a note of the proper settings in the table on the last page of this manual.

If the 4025 forgets these settings, it will display a RESET message when you turn it on. In that case, you should refer to your notes on the last page of this manual and then reset the command character and the communications parameters.

Also, if you dial up a different computer, you may have to change some of these settings to agree with what that computer expects.

The *communications parameters* which must be set correctly are:

- Transmitting and receiving baud rates.
- Parity.
- Remote or local echo.
- End-of-line string.
- Prompt string.

With these five parameters set correctly, it should be possible to log in on a computer system. Once you have logged in, each application program that you run on the computer will set the 4025's other settings as needed.

### Baud Rates

The transmitting and receiving baud rates are the speeds at which the 4025 sends and receives characters from the computer. These speeds are indicated by the "TB=" and "RB=" parts of the SYSTAT message.

**Exercise**

Examine the SYSTAT message by typing the SYSTAT command, and note the transmitting and receiving baud rates. Write these down, for future reference, in the table on the last page of this manual.

To set the transmitting and receiving baud rates, we use the BAUD command. The following baud rates may be specified: 50, 75, 100, 134, 150, 300, 600, 1200, 1800, 2400, 4800, and 9600 baud. For example, to set both transmitting and receiving rates to 600 baud, you would type:

```
!BAUD 600 <CR>
```

The transmitting and receiving baud rates may be set independently. For instance, to set the transmitting rate to 1200 baud and the receiving rate to 4800 baud, type:

```
!BAUD 1200, 4800 <CR>
```

There is a table on the last page of this manual, in which you should record the proper baud rates for use with your computer. (While the 4025 remembers its baud rate settings even after it has been turned off, it depends on an internal battery to provide power for this memory. Should the battery fail, the 4025 will display a RESET message. In that case, you would refer to your notes on the last page of this manual, and use the BAUD command to reset the 4025 to the right baud rates.)

**Parity**

The *parity* setting determines how the 4025 treats the eighth bit (*parity bit*) in each ASCII character. There are five possible parity settings: "even," "odd," "none," "high," and "data." If the host computer uses the parity bit, then the 4025's parity setting must correspond with that of the computer. (If the computer uses even parity, so must the 4025.) You can learn the 4025's parity setting from the "PA=" part of the SYSTAT message.

**Exercise**

Type the SYSTAT command, and examine the SYSTAT message. Write down the parity setting in the table in the back of this manual.

## COMMANDS

To set the 4025 for **even** parity, type:

```
!PARITY E <CR>
```

To set it for **odd** parity, type:

```
!PARITY O <CR>
```

To set parity to **none**, type:

```
!PARITY N <CR>
```

To set parity to **high**, type:

```
!PARITY H<CR>
```

To set parity to **data**, type:

```
!PARITY D <CR>
```

## Echo

When you are typing directly to the computer (typing into the monitor in unbuffered mode), there are two ways that the characters you type may be displayed on the screen: *remote echo* and *local echo*.

In **remote echo** data communications, characters typed into the monitor are sent to the computer without first being displayed. As the computer receives each character, it "echos" it back to the 4025. It is the received echo, rather than the original transmitted character, that the 4025 displays on its screen. This has the following advantages:

- As you type each character into the monitor, you can tell immediately whether the computer has received the character correctly.
- *Selective echo* is possible, because the computer can be programmed to decide which characters to echo. For instance, in time sharing systems, the computer usually does not echo the password typed when logging in.

In **local echo** data communications, as you type each character into the monitor, the 4025 supplies the echo within itself. That is, it displays each character sent to the computer without waiting for the computer to echo the character back to the 4025. Local echo data communications has the advantage that simpler, half duplex data communications links can be used. (Remote echo requires full duplex data communications, in which both computer and terminal may transmit simultaneously.)

The ECHO command is used to choose between remote echo and local echo data communications. To choose remote echo, type:

!ECHO REMOTE <CR> or !ECH R <CR>

To choose local echo, type:

!ECHO LOCAL <CR> or !ECH L <CR>

After typing an ECHO command, check the SYSTAT message to be sure that you have set the echo parameter correctly. Look for the "EC=" part of the SYSTAT message "EC=R" means "remote echo", and "EC=L" means "local echo".

### End-of-Line String

The 4025 sends the computer an *end-of-line* string at the end of each line of text. For instance, when you are typing directly to the computer (that is, with the keyboard typing into the monitor), the 4025 sends the end-of-line string whenever you press RETURN. Similarly, when sending the workspace contents to the computer, the 4025 inserts an end-of-line string at the end of each line of text.

Some computers may expect to receive *carriage return* (<CR>) at the end of each line, while others may require *carriage return, line feed*, (<CR>,<LF>) or some other string of characters. For this reason, the 4025 has an EOL command for setting the end-of-line string as required.

You can learn the current end-of-line string by examining the "EL=" part of the SYSTAT message (Fig. 3-10). Usually the end-of-line string does not include ordinary letters of the alphabet, but instead consists of one or more non-printing ASCII control characters. These control characters are represented by two-letter mnemonics in the SYSTAT message. You can learn the meanings of these mnemonics by consulting Table B-2 in Appendix B.

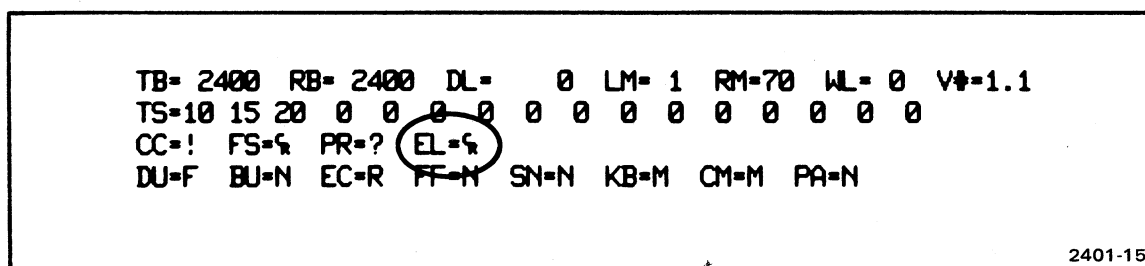

Fig. 3-10. SYSTAT indication of end-of-line string.

**Exercise**

**Type the SYSTAT command to examine the end-of-line string setting. Record this for future reference in the table on the last page of this manual.**

To set the end-of-line string, use the EOL command. The Programmer's Reference Manual describes several forms this command may take. One way to give the EOL command is to list (as parameters in the command) the ASCII decimal equivalents of the characters which are to make up the end-of-line string.

Table B-1 in Appendix B lists the ASCII decimal equivalents for all the characters of the ASCII code. For instance, the ASCII decimal equivalents for *carriage return* and *line feed* are 13 and 10, respectively. Thus, to set the end-of-line string to *carriage return, line feed*, you would type:

```
!EOL 13,10 <CR>
```

Similarly, to set the end-of-line string to be just *carriage return*, you could type:

```
!EOL 13 <CR>
```

If you omit the ASCII decimal equivalent in the EOL command, the 4025 sets the end-of-line string to *carriage return*. Thus,

```
!EOL <CR> and !EOL 13 <CR>
```

have the same effect.

After setting the end-of-line string, you should examine the SYSTAT message to be sure that you have set it correctly.

**Prompt String**

If you use the 4025 in buffered mode, you should be sure that the 4025 and the computer agree on what characters comprise the *prompt string*. (The prompt string is the character or characters which the computer sends the 4025 when it is ready for the 4025 to send it another line of text.)

You can specify any prompt string up to 10 characters by naming the ASCII decimal equivalents of those characters in the PROMPT command. (You can find the ASCII decimal equivalent for any character in Table B-1 in Appendix B.) For instance, the ASCII decimal equivalents for *ampersand* and *line feed* are 38 and 10. To set the prompt string to *ampersand, line feed*, type:

```
!PROMPT 38,10 <CR> or !PRO 38,10 <CR>
```

After setting the prompt string, you should check it by examining the "PR=" part of the SYSTAT message. The non-printing ASCII characters are represented in the SYSTAT message by two-letter mnemonics; the meanings of these mnemonics are given in Table B-2 of Appendix B.

Information on other forms of the PROMPT command can be found in the Programmer's Reference Manual.





## Section 4

# OPERATING CONSIDERATIONS

This section describes operating considerations. Topics included are:

- Things to do when you turn the 4025 on.
- Using the workspace and the monitor.
- What to do . . .
  - If you get a RESET or RAM ERROR message.
  - If the characters you type are not displayed properly.
  - If the 4025 does not respond to commands typed on its keyboard.
  - In case of difficulty.

But first, a word of caution:



*Do not place papers, books, etc. on the 4025's cabinet. Be especially careful not to cover the slits in the cabinet cover. These slits are needed to adequately ventilate the 4025's internal components.*

## WHEN YOU TURN THE POWER ON

When you turn on the 4025, or when you begin working with it, you should familiarize yourself with its current settings.

1. Press SHIFT-STATUS to examine the status message. Check to see what the command character is.

## OPERATING CONSIDERATIONS

2. Type a SYSTAT command to examine the SYSTAT message. Look especially for these things:

- Whether a workspace is defined. (“WL=0” if there is no workspace.)
- Whether text from the keyboard is directed to the workspace (“KB=W”) or to the monitor (“KB=M”).
- Whether text from the computer is directed to the workspace (“CM=W”) or to the monitor (“CM=M”).

You should also check that the 4025 is correctly set for talking to the computer. Check these parts of the SYSTAT message:

- The transmitting and receiving baud rates. (The “TB” and “RB” settings.)
- Whether the echo is remote (“EC=R”) or local (“EC=L”).
- Whether the prompt string and end-of-line string are their usual values. (The “PR” and “EL” settings.)

At the rear of this manual is a table for recording the most important SYSTAT settings for future reference.

If a RESET or RAM ERROR message is displayed when you turn on the power (or press MASTER RESET), refer to “If You get a RESET or RAM ERROR Message”, later in this section.

## USING THE WORKSPACE AND THE MONITOR

The workspace and the monitor each have specific uses. Don't use the workspace to do things for which the monitor is designed, or vice versa.

Use the **monitor** to display general conversations with a computer time-sharing system. For instance, when you first dial up a computer and “log in”, you should direct text from both the keyboard and the computer to the monitor.

Use the **workspace** only to hold the particular text or form on which you are working. Don't use it to display general conversation with the computer; this will quickly exhaust the 4025's memory.

If you are filling out a form, the form will be in the workspace, so text from the keyboard should be directed to the workspace. If the computer is filling in some of the blanks in the form, text from the computer should be directed to the workspace. Should the computer send an error message, it will first send the MONITOR H command so that the error message is displayed in the monitor and does not overprint text in the workspace.

You can use the workspace to hold text which you are editing before sending it to the computer. However, if the text is lengthy, the 4025 may run out of memory. If this happens, the text you type will overprint the last line of the workspace.

## **WHAT TO DO . . .**

### **If You Get a RESET or RAM ERROR Message**

When you turn on the 4025, or press MASTER RESET, the 4025 checks its memory before displaying the cursor. If all is well, only the cursor will appear. However, if the check discloses a memory error, one of two messages will appear.

#### **RESET**

The RESET message indicates that the 4025 has forgotten operating parameters such as the baud rate, command character, etc. (Normally, a battery-powered memory device remembers these settings when the 4025 is turned off. Should the batteries run down, the settings would be forgotten. In that case, the 4025 resets the operating parameters to their original factory settings, and displays the RESET message.)

If the RESET message appears, press SHIFT-STATUS to see the command character. Then give a SYSTAT command and examine the SYSTAT message. Compare each of the SYSTAT settings with the settings for your computer installation. (There is a table in the back of this manual in which to record your settings.) Then, by typing the appropriate commands, set these settings back to their proper values. It is particularly important to reset the transmitting and receiving baud rates, the end-of-line string, and the command character. Once these are correct, the 4025 can receive the settings for the other operating parameters from the computer.

#### **RAM ERROR**

The RAM ERROR message indicates that the 4025 has detected a malfunction within itself. You should call your Tektronix Service Center to have the 4025 repaired.

## **If the Characters You Type Are Not Displayed Properly**

If the characters you type are not displayed properly, you should examine the SYSTAT message. Check the echo setting and look to see where text from the keyboard and the computer is sent.

### **Displayed Not At All**

If you are typing into the monitor rather than the workspace, it is possible that the characters you type may not be displayed. This is probably because neither the 4025 nor the computer is providing the necessary echo of each character typed. The following are possibilities:

- You may not be connected to the computer. (You may have forgotten to dial its telephone number, or the telephone connection may be faulty.)
- The computer may not be set to echo the characters you type. In that case, you should type a command to the computer, telling it to provide this echo.
- Your computer installation may expect the 4025, rather than the computer, to provide the echo - and the 4025 is set for remote echo rather than local echo. If this is the case, type an ECHO L command on the 4025's keyboard:

```
!ECHO L <CR>
```

### **Displayed Twice**

If both the 4025 and the computer are providing echoes, the letters you type will appear twice on the screen. To remedy this, set the 4025 for remote echo, as follows:

```
!ECHO R <CR>
```

### Displayed in the Workspace when Typing into the Monitor

If the computer is providing a “remote echo” for the characters you type, it is possible for these characters to appear in the workspace, even if you are typing into the monitor. Examine the SYSTAT message, and see if the following is the case:

- Text from the keyboard is directed to the monitor (“KB=M”).
- Text coming over the communications line from the computer is directed to the workspace (“CM=W”).
- The 4025 is set for “remote echo” (“EC=R”).

If this is the case, then each character that you type into the monitor is sent to the computer, which echoes it--sends it back for display on the screen. The echoed character, coming from the computer rather than the keyboard is displayed in the workspace. To display the echoed characters in the monitor, type:

```
!MON H <CR>
```

This causes text from the computer to be directed to the monitor.

### If the 4025 Does Not Respond to Commands

If the 4025 does not respond to commands, check the following things:

1. Look to see if the COMMAND LOCKOUT light is on. If it is, press the COMMAND LOCKOUT key to turn it off.
2. Press SHIFT-STATUS, and examine the status message:
  - Is the command character what it should be? If you type commands using the exclamation point (!) when the command character is the ampersand (&), the 4025 will not understand the commands. If the 4025 is set to the wrong command character, use the COMMAND command to set it back. For instance, if the command character is the exclamation point, you can change it to the ampersand by typing this:

```
!COMMAND & <CR>
```

## OPERATING CONSIDERATIONS

- Is the 4025 in buffered mode? (If it is, the first letter of the status message will be B instead of U.) In buffered mode, the 4025 cannot execute commands until it has emptied its transmit buffer - and it cannot empty the transmit buffer until it receives the necessary prompts from the computer.

You can break the 4025 out of buffered mode, so that it will respond to commands, by pressing the BREAK key twice in quick succession. (This also sends a "break" signal to interrupt the computer.)

### **In Case of Difficulty**

In case of difficulty, press SHIFT-STATUS and examine the status message (see Exercise 5 in Section 2). Then type the SYSTAT command and examine the SYSTAT message (see the "Systat" Message, Section 3).

## Section 5

# CREATING FORMS

This section describes how to create a *form* in the workspace, with *blanks* that either you or the computer can fill in. Topics included are:

- General overview: form fillout mode, creating a form.
- Basic concepts: lines and fields, the display list, attribute codes.
- The ATTRIBUTE command: how it affects the display list.
- Visual attributes: *enhanced* and *inverted* backgrounds, underlines, blinking underlines, etc.
- Logical attributes: *protected* and *unprotected* fields, and the *alphanumeric* and *numeric* types of unprotected fields.
- Character set attributes: alternate character fonts.
- Rulings: drawing vertical and horizontal lines on a form.

## GENERAL OVERVIEW

Creating a form consists of attaching properties, or *attributes*, to parts of the workspace. The process is as follows:

1. With the 4025 not in form fillout mode use the **ATTRIBUTE** command to create the form. (The **ATTRIBUTE** command is described later in this section.)
2. By means of a **FORM** or **FORM YES** command, put the 4025 into form fillout mode.

Once you have created the form, you can use it: fill in the blanks, send the contents of the blanks to the computer, etc. The special properties of forms, and of form fillout mode, are described in Section 3, under "Form Fillout Mode".

When done using the form, you would usually:

1. Remove the 4025 from form fillout mode with a **FORM NO** command.
2. Erase the workspace and use it for something else.

### NOTE

*The **ATTRIBUTE** command, used to create forms, has no effect when the 4025 is in form fillout mode. Therefore, one must always create a form with the 4025 not in form fillout mode, and then put it into form fillout mode with a **FORM** or **FORM YES** command.*

*Also, in form fillout mode, certain parts of the form are protected from being erased or written over. Therefore, in order to erase a form, one must always remove the 4025 from form fillout mode.*



## BASIC CONCEPTS

### Lines and Fields

Figure 5-1 shows the parts of a typical form. A form consists of several *lines* of text in the workspace. Each line consists of one or more *fields*, which are subdivided into the individual characters of text.

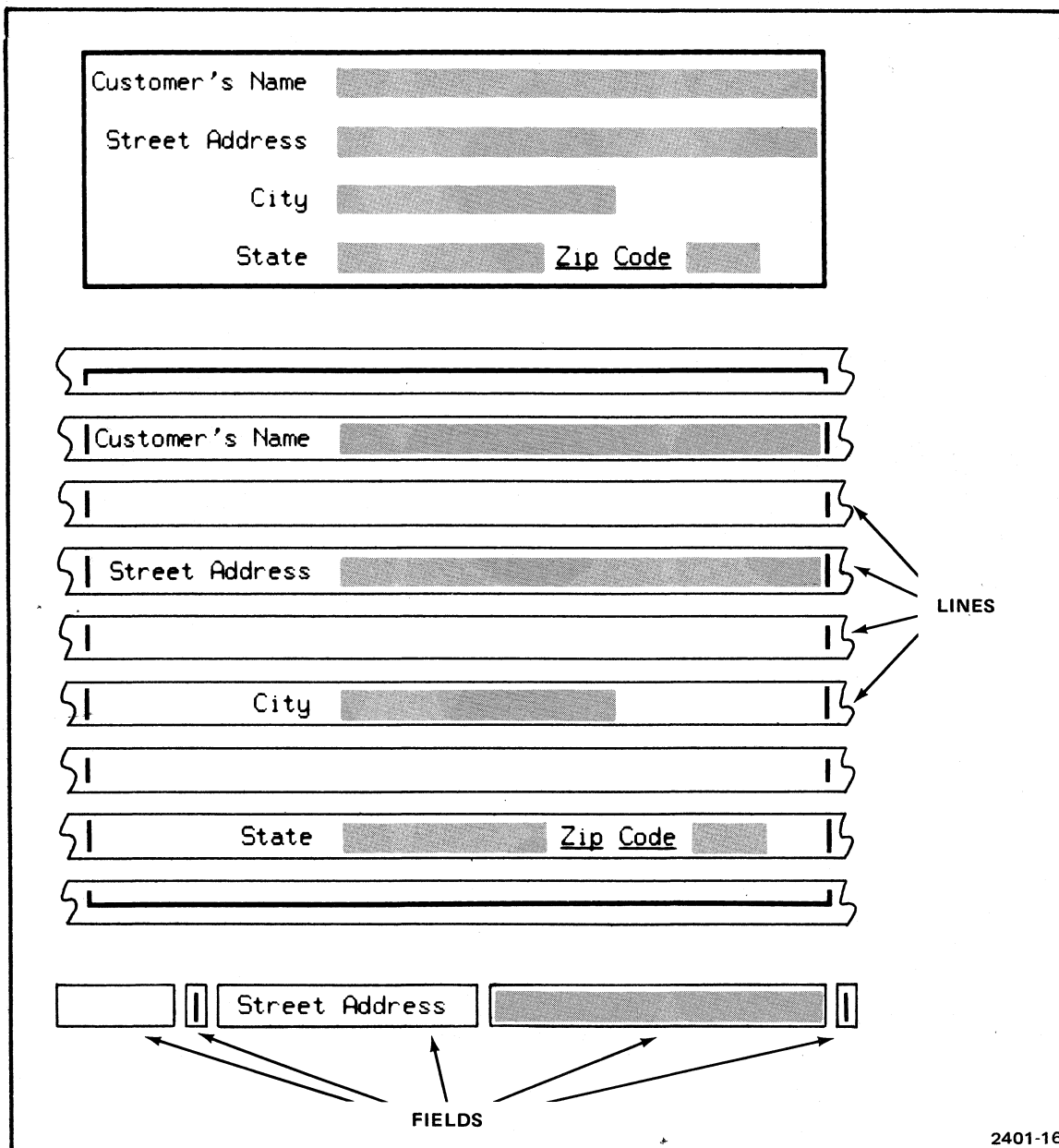

Fig. 5-1. The parts of a typical form.

### The Display List and Attribute Codes

To display text in the workspace, the 4025 must store that text in a part of its memory reserved for the workspace scroll. This part of memory is called the workspace's *display list*. In addition to characters actually displayed on the screen, the display list includes markers which are not displayed. These markers are of two types:

- Markers indicating where one line of text ends and the next begins.
- Markers, called *attribute codes*, that divide a line into fields and determine the properties (*attributes*) of those fields. (Fig. 5-2.)

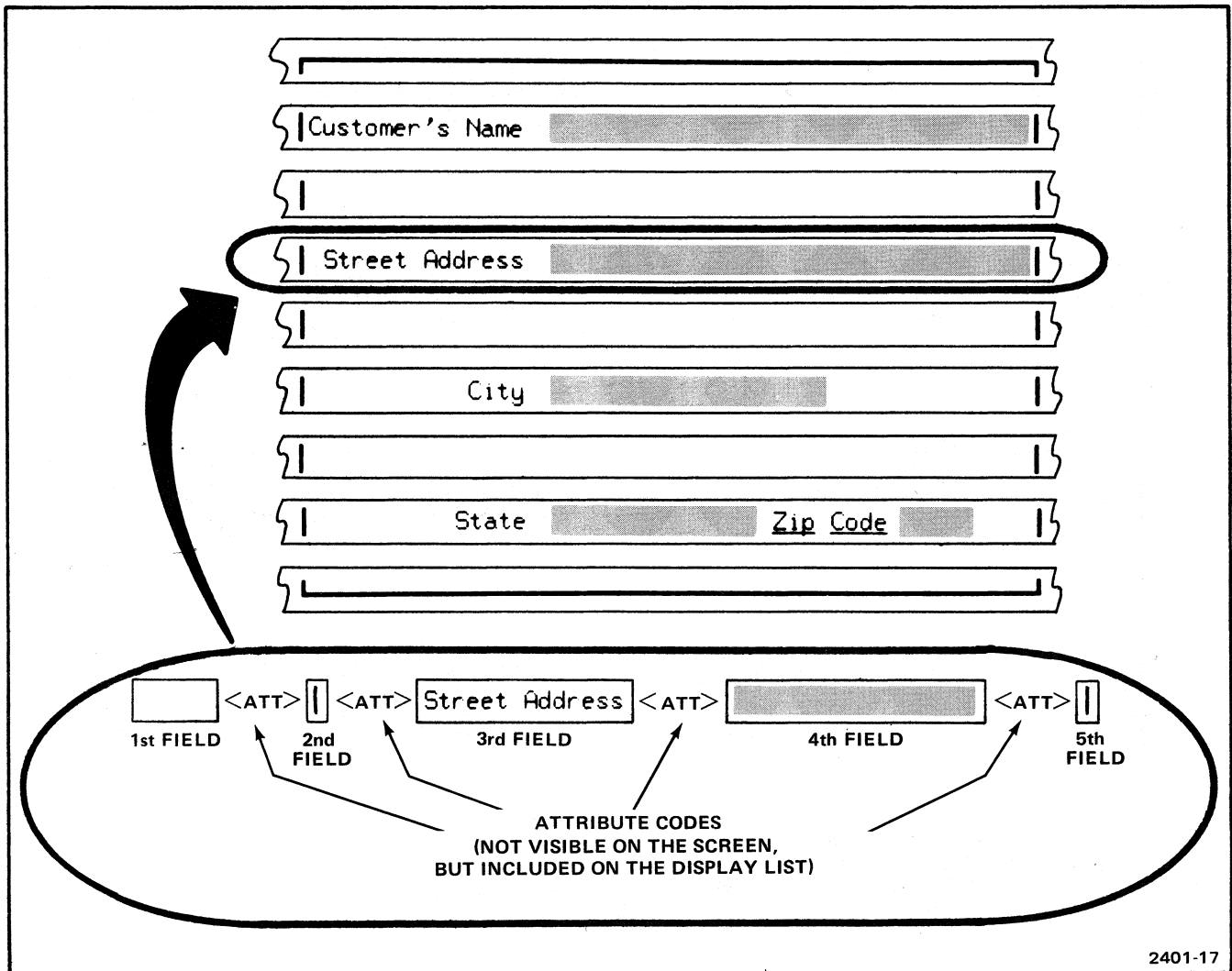

Fig. 5-2. Position of attribute codes in a display list.

Field attributes are of three types:

- Visual attributes: *standard, enhanced, inverted, underlined*, and combinations of the last three.
- Logical attributes: *alphanumeric, numeric, and protected*.
- Character font attributes: *font zero, font one, font two, etc.*

The 4025 scans the display list from left to right across each line. When it encounters an attribute code, it starts a new field. It may also change one or more of the attributes in effect, as called for by that attribute code. Each line starts with the *default* attributes: *standard* visual attribute, *alphanumeric* logical attribute, and *font zero* character font attribute .

If an attribute code specifies a visual attribute, the fields to its right will have that visual attribute until another attribute code changes the visual attribute in effect. However, the logical and character font attributes do not change unless the attribute code also specifies new logical or character font attributes.

Similarly, the logical attribute may change without affecting the visual or character font attributes, and a character font attribute may change without affecting visual or logical attributes.

Figure 5-3 illustrates the process. As the 4025 scans the display list, it begins the line with the default attributes. The first attribute code changes the visual attribute to *enhanced*, but does not affect the logical or character font attributes. The second attribute code changes the visual attribute “underlined”, and the logical attribute to “protected”.

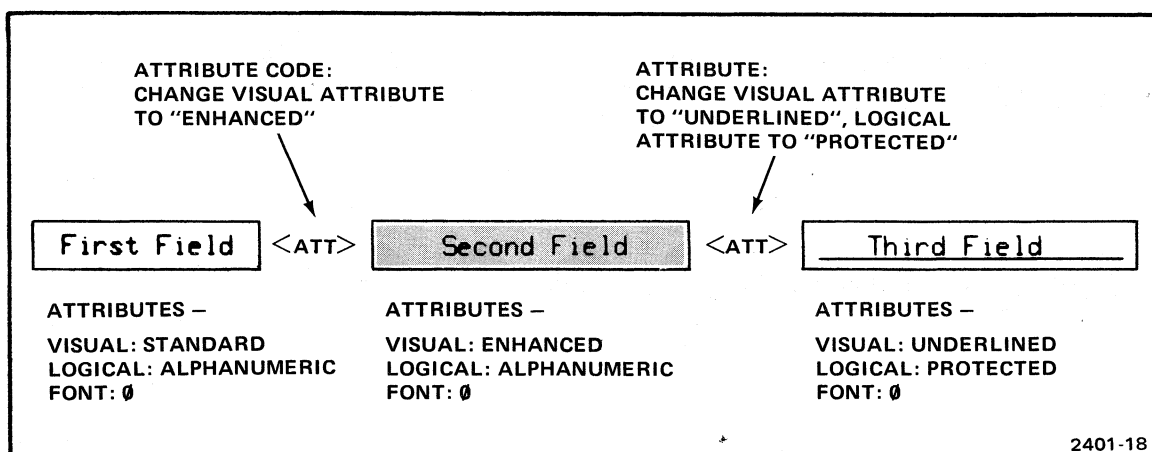

Fig. 5-3. Effect of field attribute codes.

## The ATTRIBUTE Command

Earlier in this section, we stated that creating a form consists of attaching attributes to parts of the workspace. This may now be restated with more precision: We create forms by using the ATTRIBUTE command to insert field attribute codes into the display list.

To see how the ATTRIBUTE command works, do the following exercise:

1. First, define a workspace, if one is not already defined. (See "Defining a Workspace" in Section 3.) Direct the keyboard to type into that workspace. (See "Directing Text to the Workspace or the Monitor", in Section 3.)
2. Erase the workspace, and type the following text:  

The quick brown fox jumped over the lazy dog's back.
3. Move the cursor to the letter "q" that starts the second word of the test sentence.
4. Type the ATTRIBUTE E command:

**!ATTRIBUTE E <CR> or !ATT E <CR>**

You have now divided the line into two fields. The first field has the standard visual attribute, while the second field, starting with the word "quick", has the enhanced visual attribute.

5. Move the cursor to the start of the word "brown", and type ATTRIBUTE I command:

**!ATTRIBUTE I <CR> or !ATT I <CR>**

Now the line is divided into three fields. The first field has the standard visual attribute, the second field the enhanced visual attribute, and the third field the inverted visual attribute.

When you typed the ATTRIBUTE commands, you inserted attribute codes into the display list. The first ATTRIBUTE command, typed when the workspace's cursor was at the start of the word "quick", inserted an attribute code just before that word. Likewise, the second ATTRIBUTE command inserted an attribute code just before the word "brown".

We may summarize the previous exercise as follows:

To insert an attribute code into the display list:

1. Move the cursor (with the cursor control keys) to the place in the workspace where you want to put the attribute code.
2. Type the appropriate ATTRIBUTE command on the keyboard.

### Syntax

Figure 5-4 illustrates the format, or *syntax*, of the ATTRIBUTE command.

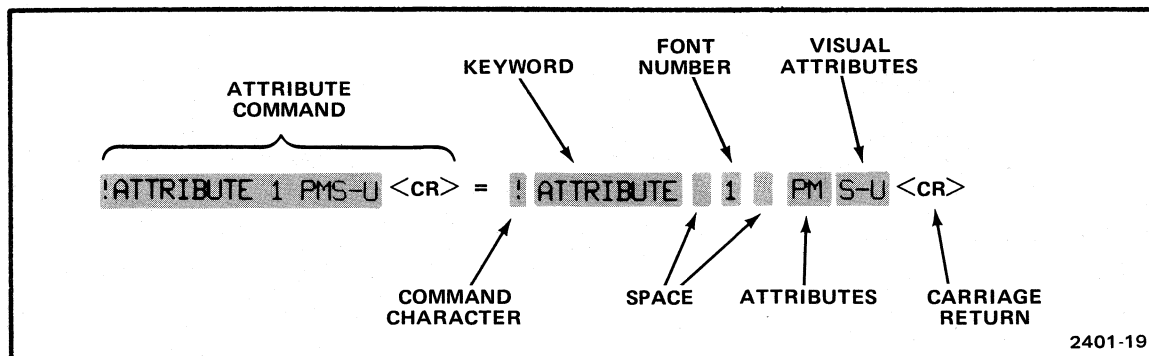

Fig. 5-4. Parts of the ATTRIBUTE command.

There are eight possible parts to an ATTRIBUTE command, some of which are optional:

- The command character (required).
- Immediately after the command character, the word ATTRIBUTE (required). It may be abbreviated to its first three letters. No spaces are allowed between the command character and the keyword.
- A space (required) to separate the keyword from the parameters to follow.
- A number (optional) to designate which of several character fonts is to be used in the field to follow. (This will be discussed later, under "Alternate Character Sets".)

## CREATING FORMS

- A space (optional) to separate the number designating the character font from the parameters to follow.
- One or more letters (optional) to designate logical attributes.
- One or more letters (optional) to designate visual attributes. No spaces are allowed between the characters designating logical and visual attributes.
- A carriage return to mark the end of the command. (A *terminator* to end the command is required; carriage return is one such terminator. The Programmer's Reference Manual describes other possible terminators.)

Now that the general syntax of the ATTRIBUTE command has been discussed, we'll examine the visual, logical, and character font attributes in more detail.

## VISUAL ATTRIBUTES

A field's visual attributes determine how it is displayed on the screen. The default visual attribute is *standard*. Other visual attributes are *enhanced*, *inverted*, and *underlined*. These attributes may be used alone or in combination.

### Standard

The *standard* attribute is the absence of the other three visual attributes. It is denoted by the letter S in the ATTRIBUTE command. Since standard is the default visual attribute, you don't need an ATTRIBUTE command to designate the first field of a line as standard.

### Enhanced

The *enhanced* visual attribute makes the background of a field brighter than standard. The letter E denotes enhanced in ATTRIBUTE commands.

#### Exercise

Move the cursor down a few lines in the workspace and type the test sentence:

The quick brown dog jumped over the lazy fox's back.

Now move the cursor to the start of the word "quick", and type an ATTRIBUTE E command:

**!ATTRIBUTE E <CR> OR !ATT E <CR>**

Move the cursor to the start of the word "brown", and type an ATTRIBUTE S command:

**!ATTRIBUTE S <CR> OR !ATT S <CR>**

The two attribute codes you inserted divide the line into three fields. The first field has the standard visual attribute, since each line starts with the default attributes unless you specify differently with an ATTRIBUTE command at the start of the line. The second field has the enhanced attribute: (its background is brighter than standard. The third field has the standard attribute once again.

## Inverted

The *inverted* visual attribute displays a field with dark characters on a light background, rather than light characters on a dark background. *Inverted* is designated by the letter I in the ATTRIBUTE command.

### Exercise

Experiment with the ATTRIBUTE I command: Move the cursor to any spot in the text in the workspace, and then type:

**!ATT I <CR>**

## Underlined

The *underlined* attribute underlines each character of a field. It is represented in ATTRIBUTE commands by the letter U.

### Exercise

Try out the ATTRIBUTE U command:

**!ATT U <CR>**

## Using More Than One Visual Attribute

An ATTRIBUTE command can specify more than one visual attribute. For instance, these are all valid ATTRIBUTE commands:

```
!ATT EU <CR>
```

```
!ATT IU <CR>
```

```
!ATT LIE <CR>
```

The first example sets up a field in which the letters appear on an enhanced background and are underlined. The second example defines a field with both inverted and underlined visual attributes, while the third example combines all three visual enhancements: underlined, inverted, and enhanced.

Although a field may have more than one visual attribute at a time, the standard attribute may not be among them. This is because the standard attribute is the absence of the other visual attributes.

## Blinking Between Visual Attributes

You can set up a field which *blinks*, or alternates, between two visual attributes or sets of visual attributes. To do this, specify both visual attributes (or sets of visual attributes) in the ATTRIBUTE command, separating them with a hyphen, as follows:

```
!ATT S-U <CR>
```

```
!ATT E-I <CR>
```

```
!ATT IU-EU <CR>
```

The first of these examples defines a field which alternates between standard and underlined. The second example makes a field alternate between enhanced and inverted, while the third example defines a field which blinks between “inverted with underline” and “enhanced with underline”.



## LOGICAL ATTRIBUTES

Visual attributes may give interesting visual effects, but it is the *logical* attributes of fields in a form which make the form behave as a form, rather than just as a collection of words in the workspace.

Logical attributes have effect only when the 4025 is in form fillout mode. (You create the form with the 4025 not in form fillout mode, and then put it into form fillout mode with a FORM YES command.) With the 4025 in form fillout mode, fields have the following logical properties:

- Those fields with *protected* logical attributes act as the permanent parts of the form. That is, they are the parts which remain the same each time the form is filled out.
- Those fields with *unprotected* logical attributes comprise the form's blanks. These are the blanks into which you type when filling out the form.

You can specify four different logical attributes in ATTRIBUTE commands: the *alphanumeric*, *numeric*, *protected*, and *modified* attributes. The first two of these specify different kinds of unprotected fields. The *protected* attribute sets up protected fields. *Modified* is an additional attribute which you may give to fields which you have already designated protected.

### Alphanumeric

The first logical attribute is called *alphanumeric unprotected*, or *alphanumeric* for short. You can type any text into alphanumeric fields. Such fields are used as the blanks of a form.

Alphanumeric is the default logical attribute. That is, each line starts with an alphanumeric field, unless you specify otherwise with an ATTRIBUTE command. The alphanumeric attribute remains in effect until the first field whose attribute code specifies a different logical attribute.

## CREATING FORMS

In the `ATTRIBUTE` command, the letter `A` designates an alphanumeric field. For example, these two commands set up alphanumeric fields:

```
!ATTRIBUTE A <CR>
```

```
!ATT AE <CR>
```

The first command sets only the logical attribute of the field it defines; that field will share the visual attributes of the preceding field in its line. The second command sets up an alphanumeric field and defines that field's visual attribute to be enhanced.

### Numeric

The second logical attribute is *numeric unprotected*, or *numeric* for short. Like alphanumeric fields, numeric fields are used for the blanks of a form. The difference is that numeric fields will not accept letters of the alphabet. You can type numbers and certain special symbols into a numeric field, but not letters.

In an `ATTRIBUTE` command, the letter `N` designates a numeric field. For instance, these commands set up numeric fields:

```
!ATTRIBUTE N <CR>
```

```
!ATT NE <CR>
```

```
!ATT NS-U <CR>
```

The first of these examples sets up a numeric field, but does not specify the visual attributes of that field. The field will share the visual attributes of the preceding field in its line.

The second example defines a numeric field with the enhanced visual attribute.

The third example defines a numeric field that alternates between the standard and underlined visual attributes. That is, it defines a numeric field with a blinking underline.

### Protected

The *protected* logical attribute designates the permanent fields of a form. These are the fields into which you cannot type with the 4025 in form fillout mode.

In an ATTRIBUTE command, the letter P designates a protected field. For instance, these commands set up protected fields:

```
!ATTRIBUTE P <CR>
```

```
!ATT PE <CR>
```

```
!ATT PI-E <CR>
```

The first example sets only the logical attribute of the field it defines. That field shares the visual attributes of the preceding field in its line.

The second example defines a protected field with the enhanced visual attribute, while the third example sets up a protected field which blinks between the inverted and enhanced visual attributes.

## Modified

*Modified* is an additional attribute which you can attach to a protected field. (There is no benefit to specifying an unprotected field as modified, although there is nothing to prevent you from doing so.)

The modified attribute affects how a field is treated when the 4025 executes a SEND MOD command. In form fillout mode, SEND MOD sends to the computer the contents of only those blanks whose contents have been modified. Ordinarily, this is text from unprotected fields whose contents have not already been sent to the computer. However, you can also designate protected fields as modified, so that their contents will also be sent during a SEND MOD operation.

To designate a protected field as modified, use the letter M in the ATTRIBUTE command that sets up the field. For instance, these commands define fields with the modified logical attribute:

```
!ATTRIBUTE PM <CR>
```

```
!ATT PMS-U <CR>
```

```
!ATT M <CR>
```

In the first example, the ATTRIBUTE command sets up a protected field which is tagged as modified for future SEND MOD operations. Since the command does not specify the visual attributes, this field shares the visual attributes of the preceding field in its line.

## CREATING FORMS

The second example sets up a protected field, labels it modified for SEND MOD operations, and causes it to be displayed with a blinking underline.

The third example sets up a new field and attaches the modified label for SEND MOD operations. The field shares the other logical and visual attributes of the preceding field in its line. If the preceding field is protected, then this field will be protected also; if the preceding field is displayed with a blinking underline, this field will have a blinking underline also.

(See the Programmer's Reference Manual for more information on the modified logical attribute and the SEND MOD command.)

## ALTERNATE CHARACTER SETS

Provided certain options are installed, the 4025 can display characters of alternate alphabets in its workspace. Besides the ordinary English alphabet, there are *rulings* characters (Option 32), *math* characters (Option 34), and others. If your 4025 has the Graphics Memory option (Option 23, 24, 25, or 26), you can even create new alphabets by telling the 4025 how to draw the characters of those alphabets.

The different character sets, or *fonts*, are numbered. Font 0 is always the standard character set. The rulings characters, if installed, comprise Font 1; other fonts have different numbers.

The attribute code starting a field may name the character font for that field, as well as the logical and visual attributes. Each line starts with font 0, the standard character set. To switch to another font, an attribute code naming that font is needed.

To name a character font, give the font number in the ATTRIBUTE command:

```
!ATTRIBUTE 1 <CR>
```

```
!ATT 0 <CR>
```

```
!ATT 2 PE <CR>
```

The first example specifies Font 1, the *rulings* font. (The characters of the rulings font are used to draw vertical and horizontal lines on a form. They are discussed later in this section, under "Drawing Rulings".)

The second example names Font 0, the standard character set. (Font 0 is the default font; each line in the workspace starts with Font 0, unless another font is specified with an **ATTRIBUTE** command at the start of the line.)

The third example specifies Font 2. This command also specifies the protected and enhanced attributes for the field it defines.

## RULINGS

As mentioned earlier, one of the alternate character sets is the *rulings* set (Option 32). The rulings characters are used to place horizontal and vertical lines in a form, and to join those lines.

The rulings characters, if installed, are Font 1. (The standard character set is Font 0.) One way to see the rulings characters is to define a field using Font 1, and then type the letters of the alphabet into that field. For each letter, a corresponding rulings character is displayed.

### Exercise

If you have not already done so, define a workspace and set the keyboard to type into that workspace. Move the cursor to the start of a new line, and type an **ATTRIBUTE 1** command. For instance, if the command character is the exclamation point (!), type:

**!ATTRIBUTE 1 <CR> or !ATT 1 <CR>**

Then type the letters of the alphabet. As you type each letter, the corresponding rulings character will appear. (If the rulings character set is not installed, you will see "blotches", character cells in which all dots are turned on.)

Move the cursor to another line, and type the alphabet again. Then move the cursor back to the start of the line, and type another **ATTRIBUTE 1** command. Notice that the display changes from the standard character set to the rulings character set.

You can change back to the standard character set with an **ATTRIBUTE 0** command, since the standard character set is Font 0.

## Drawing Rulings

The easiest way to draw rulings is by means of the rulings commands, VRULE and HRULE. In each command, you define the line to be drawn (in the workspace) by specifying four numbers:

- The first number in the command tells the 4025 at which line of the workspace to begin the ruling.
- The second number specifies at which character position in that line to put the first rulings character.
- The third number specifies how many character positions the ruling is to occupy.
- The fourth number specifies whether the ruling is to be a single line or a double line.

The VRULE command draws vertical rulings, and the HRULE command draws horizontal rulings.

### Exercise

Type an HRULE 1,1,10,1 command. That is, if the command character is the exclamation point, type:

```
!HRULE 1,1,10,1 <CR>
```

The 4025 will draw a horizontal ruling, starting at the first line of the workspace, first character in that line, and continuing for 10 character positions. The ruling drawn will be a single line, rather than a double line.

Now try these commands:

```
!HRULE 2,1,10,2 <CR>
```

```
!HRULE 5,10,10,1 <CR>
```

```
!VRULE 1,1,10,1 <CR>
```

```
!VRULE 1,10,10,2 <CR>
```

As the 4025 executes a VRULE or HRULE command, it does the following things:

- First, the 4025 inserts attribute codes to set up *rulings fields*. A rulings field is a field in which characters are displayed using the rulings characters, Font 1. An HRULE command draws its ruling in only one line of the workspace, so only one rulings field is needed. A VRULE command, however, inserts a one-character rulings field in each horizontal line through which the vertical ruling passes.
- Secondly, the 4025 inserts characters in the rulings field or fields it has created.

For single vertical lines, it inserts the left bracket character (|), which appears as a vertical line when displayed with the rulings font.

Similarly, for a double vertical line, it inserts the underscore character (=); for a single horizontal line, the capital letter Y; and for a double horizontal line, the right bracket (|).

- Thirdly, the 4025 terminates each rulings field by inserting another attribute code after the rulings field. This attribute code defines a new field and returns the character font to what it was before the rulings characters were inserted.

### Getting the Junctions Right

While the HRULE and VRULE commands are convenient, they do not automatically provide the correct characters to draw the junctions where one ruling joins another. To display these junctions correctly, we need other rulings characters.

Figure 5-5 shows all the rulings characters, both as they are displayed in rulings fields (fields in which Font 1 is used) and as displayed with the standard character font (Font 0). You can quickly pick out from this figure exactly which character you need to make a neat junction between two rulings.

Rulings (Font 1)	Standard (Font 0)
	<pre>@YYGYAYYYYB [ - [ [ \]]M]]K]]]]^ [ - [ [ HYYOYYIYYYYJ [ - [ [ [ - [ [ [ - [ [ PYYWYYQYYYYR</pre>
	<pre>D]]C]]E]]]]]F - [ - - XYYIYYOYYYYZ - [ - - L]]K]]M]]]]]N - [ - - - [ - - - [ - - T]]S]]U]]]]]V</pre>
	<pre>d))c))e)))]f ? [ ? ? xYYIYYoYYYYz ? [ ? ? l))k))m)))]n ? [ ? ? ? [ ? ? ? [ ? ? t))s))u)))]v</pre>
	<pre>h]]E]]]]]]]j [ - [ [ - [ :))y)))]~ [ - [ [ - [ p]]]]]]U]]]r</pre>
	<pre>a]]]]g]]]]]b - ? - - ? - XYYYYoYYYYX - ? - - ? - qYYYYwYYYYYi</pre>

TO MAKE AN "UPPER LEFT CORNER", USE THE @ CHARACTER

Fig. 5-5. Rulings characters.



To illustrate how to use the figure, let's draw the following form:

n	2n	3n	4n
1	2	3	4
2	4	6	8
3	6	9	12
4	8	12	16
5	10	15	20
6	12	18	24

We begin by erasing the workspace and drawing the rulings with several rulings commands. Assuming the command character is the exclamation point, we type:

```
!VRU 3,20,10,1 <CR>
!VRU 3,30,10,1 <CR>
!VRU 3,40,10,1 <CR>
!VRU 3,50,10,1 <CR>
!VRU 3,60,10,1 <CR>
!HRU 3,20,41,1 <CR>
!HRU 5,20,41,2 <CR>
!HRU 12,20,41,1 <CR>
```

At this point, the workspace looks like this:

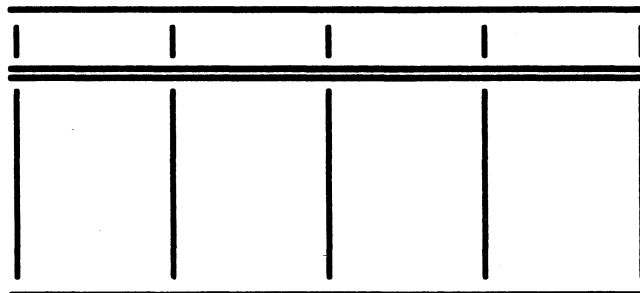

The rulings are in place, but their junctions aren't right. To remedy this, we consult Fig. 5-5 to see which characters, when displayed in the rulings font, give the correct junctions. For instance, we see that the upper left corner can be made with an @ character, that the "T" junctions in the top row can be made with the letter A, and that the upper right corner can be made with the letter B.

## CREATING FORMS

Accordingly, we move the cursor to the upper left corner of the box formed by the rulings, and type an @ . The rulings character for the upper left corner appears. Similarly, we move the cursor to the "T" junctions along the top of the form, and type the letter A at each junction; the rulings characters for the "T" junctions appear.

Likewise, we type the letter B at the upper right corner of the rulings, and the characters, \, K, K, K, ^ at the five junctions of the horizontal double line with the vertical lines. We finish making the junctions by typing the characters P, Q, Q, Q, R at the junctions of the bottom horizontal line with the vertical lines.

At this point, the workspace looks like this:

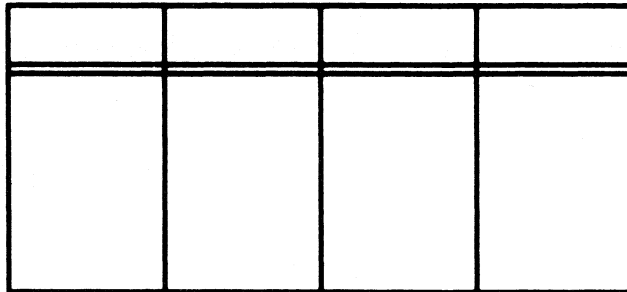

To finish the form, we need only type the text inside the boxes formed by the rulings characters.

## Section 6

# GRAPHICS

If your 4025 has the Graphics Memory option (Option 23, 24, 25, or 26), you can create a *graphics area* in the workspace and draw graphs there. The graphs can be made of solid lines or a variety of dashed lines. This section describes how to do this.

In addition, with the graphics option installed, you (or the computer) can create additional character sets, or *fonts*. In these fonts, you can specify any characters you choose, by telling the 4025 how to draw them. (To learn how to do this, see the Programmer's Reference Manual.)

Topics in this section are:

- The GRAPHIC command, which sets up a graphics area in the workspace.
- The VECTOR command, which draws lines in the graphics area.
- The ERASE G command, which erases all lines drawn in the graphics area.
- The LINE command, which specifies the type of line the VECTOR command draws. Lines can be solid or dashed, or they can be "erase vectors" (invisible) which erase lines previously drawn.

### The GRAPHIC Command

The GRAPHIC command defines the boundaries of a *graphics area* in the workspace. This area is the "graph paper" on which the VECTOR command draws lines. The following example illustrates the GRAPHIC command:

```
!GRA 2,11,20,49 <CR>
```

This creates a graphics area which occupies (in the workspace) rows 2 through 11, columns 20 through 49. This graphics area, 30 cells wide and ten cells high, holds 300 character cells (Fig. 6-1).

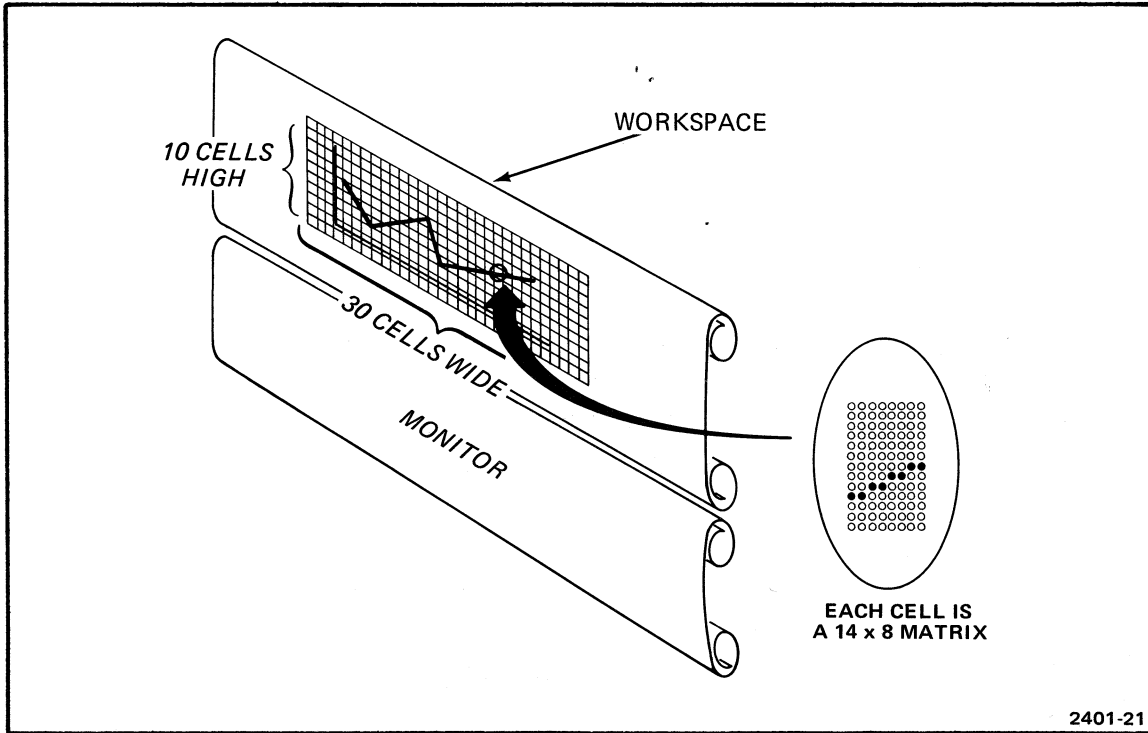

Fig. 6-1. A graphics area.

Each cell contains 112 dot positions; it is 8 dots wide and 14 dots high. Each dot can be turned on or off (displayed as light or dark). The VECTOR command draws lines by turning on patterns of these dots.

The columns of dots are numbered from left to right across the graphic area, starting with 0 for the leftmost column. In this example, the 240 columns of dots (30 cells, each 8 dots wide) are numbered from 0 to 239.

This graphics area has 140 rows of dots: it is 10 cells high, each cell 14 dots high. These rows are numbered from 0 to 139 from bottom to top.

Thus, for each dot in the graphics area, there is a pair of numbers: its x- and y-coordinates. The x-coordinate names the column in which the dot is located, and so gives its position from left to right across the graphics area. Likewise, the y-coordinate gives the dot's vertical position. These coordinates are used in the VECTOR command.

### The VECTOR Command

The VECTOR command draws lines in the graphics area. Each VECTOR command names two or more points by their x- and y-coordinates. The VECTOR command draws a series of line segments, starting at the first point, and passing through the other points named in the command.

For instance,

```
!VEC 0,0 10,10 50,100 <CR>
```

tells the 4025, "Start at location (0,0), the lower left corner, and draw a line to location (10,10). From there, draw a line to (50,100)". (The parameters 0, 0, 10, 10, 50, 100 may be separated by either commas or spaces.)

Again, the command

```
!VEC 120,120 91,30 168,85 72,85 149,30 120,120 <CR>
```

tells the 4025, "Start at (120,120) and draw a line to (91,30); from there draw a line to (168,85), and so on through points (72,85), (149,30), and (120,120)". Fig. 6-2 shows the effect of this command.

If, in a VECTOR command, you specify a point which lies outside the graphics area, the 4025 does not try to draw a line to that point. It resumes drawing with the next line segment which lies entirely within the graphics area.

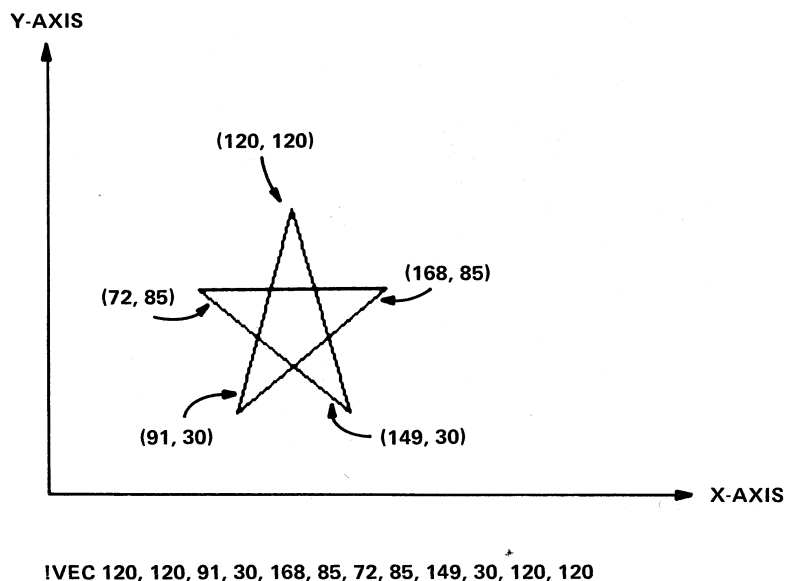

2401-22

Fig. 6-2. Effect of a VECTOR command.

## The ERASE G Command

The ERASE command with the parameter G (rather than M or W) erases all lines in the graphics area without affecting the rest of the workspace.

### Exercise

Try setting up a graphics area with the GRAPHICS 2,11,20,49 command described earlier.

Draw a few lines in that graphics area, using VECTOR commands. (Be sure to keep the x-coordinates in the range 0 to 239, and the y-coordinates in the range 0 to 139.)

Type an ERASE G command:

```
IERASE G <CR> or IERA G <CR>
```

The 4025 erases the lines you have drawn. If you wish, you may use the VECTOR command to draw more lines; the graphic area itself has not been removed, just the lines drawn in it. (However, if you erase the workspace with the ERASE key or the ERASE W command, the graphic area is destroyed with the rest of the workspace contents.)

## The LINE Command

The LINE command specifies the type of lines that subsequent VECTOR commands will draw.

### Exercise

Type these commands:

```
IERA G <CR>  
!LIN 2 <CR>  
!VEC 0,0 100,100 <CR>  
!VEC 0,0 200,100 <CR>  
!LIN 1 <CR>  
!VEC 0,0 150,100 <CR>
```

The ERASE G command erases all previously drawn lines from the graphics area. The LINE 2 command then sets the line type to type 2 (a dashed line), and the two VECTOR commands draw two of these dashed lines. The second LINE command sets the line type back to type 1 (solid line); the final VECTOR command draws a solid line.

There are ten line types, which you may specify in the LINE command with the numbers 1 through 8, or the letters E and P. If no numbers or letters are specified, line type 1 is assumed--a solid line. Line types 2 through 8 are different styles of dashed lines, shown in Fig. 6-3.

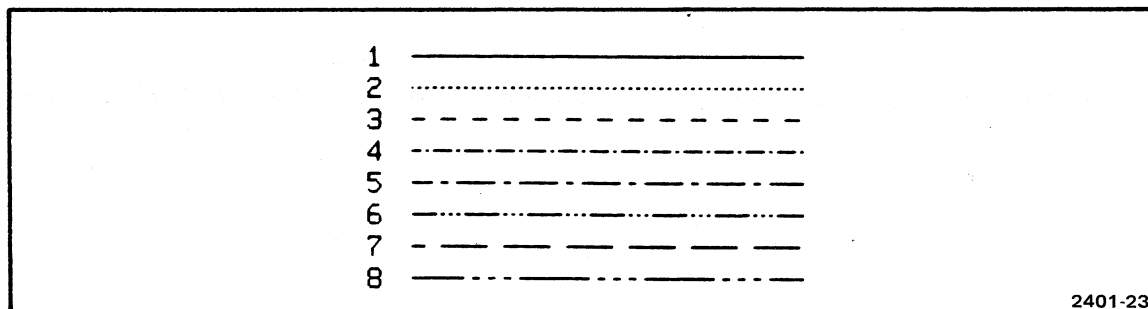

Fig. 6-3. Line types.

If you specify line type E in a LINE command, the VECTOR commands that follow draw *erase vectors*. These erase vectors are invisible; they do not draw lines, but instead erase any lines in their paths. You can erase previously drawn lines by drawing over them with erase vectors.

If you specify line type P in a LINE command, any VECTOR commands that follow do not draw lines, but only plot points. For instance, the commands

```
!LIN P <CR>
!VEC 0,0 50,50, 100,100 <CR>
```

Set the line type to P and turn on dots at the points (50,50) and (100,100). The VECTOR command tells the 4025, "Move from (0,0) to (50,50) and plot a point there; then move to (100,100) and plot another point".

### 4010-Style Graphics Commands

The 4025 will accept graphics commands given in the format used by TEKTRONIX 4010-series terminals. This format is discussed in the Programmer's Reference Manual.

You can use the following commands to set the 4025 to respond properly to 4010-style commands:

```
!GRAPHIC 1,35 <CR>
!SHRINK <CR>
```

## GRAPHICS

(The GRAPHIC command sets up a graphics area which is the right shape for holding a 4010-style graphics display. The SHRINK command accommodates the 4025 to the dimensions of a 4010-style graphic display; this command is described in the Programmer's Reference Manual.)

Once you have given the 4025 the GRAPHIC 1,35 and SHRINK commands, you may send it graphic commands like those used for the 4010-series terminals. The 4025 may, however, run out of graphic memory if the picture it is asked to display has too many lines. If this happens, the 4025 will display as much of the picture as its memory allows.



## Section 7

# MAKING HARD COPIES

Provided your 4025 has the correct options installed, you can make hard copies of the text in its memory on two different devices: the TEKTRONIX 4631 Hard Copy Unit or the 4642 Printer.

### Copying on a 4631 Hard Copy Unit

If Option 40 (Hard Copy and Video Out) is installed, you can use a TEKTRONIX 4631 Hard Copy Unit (Fig. 7-1) to make copies of the contents of the workspace or the monitor, or of what is in view on the screen. The copies can show anything that can be displayed on the screen, including rulings, alternate character sets, and graphs. One or several 53-line pages from the workspace or the monitor can be copied. Each page of copy is about 8½ by 11 inches in size, and can show more of the text than can be displayed at once on the screen.

To copy the 4025's screen, type:

```
!HCOPY S <CR> or !HCO S <CR>
```

To copy one page of the contents of the workspace, type:

```
!HCOPY W <CR> or !HCO W <CR>
```

To copy one page of the monitor, type:

```
!HCOPY M <CR> or !HCO M <CR>
```

**MAKING HARD COPIES**



**Fig. 7-1. Hard copies on a 4631 Hard Copy Unit.**

Fig. 7-2 illustrates what happens when you make a hard copy from the workspace or the monitor. Notice that the copy shows more of the workspace or monitor scroll than is in view on the screen. The copy starts with the line of the scroll which occupies the top line of the screen, and continues for a total of 53 lines.

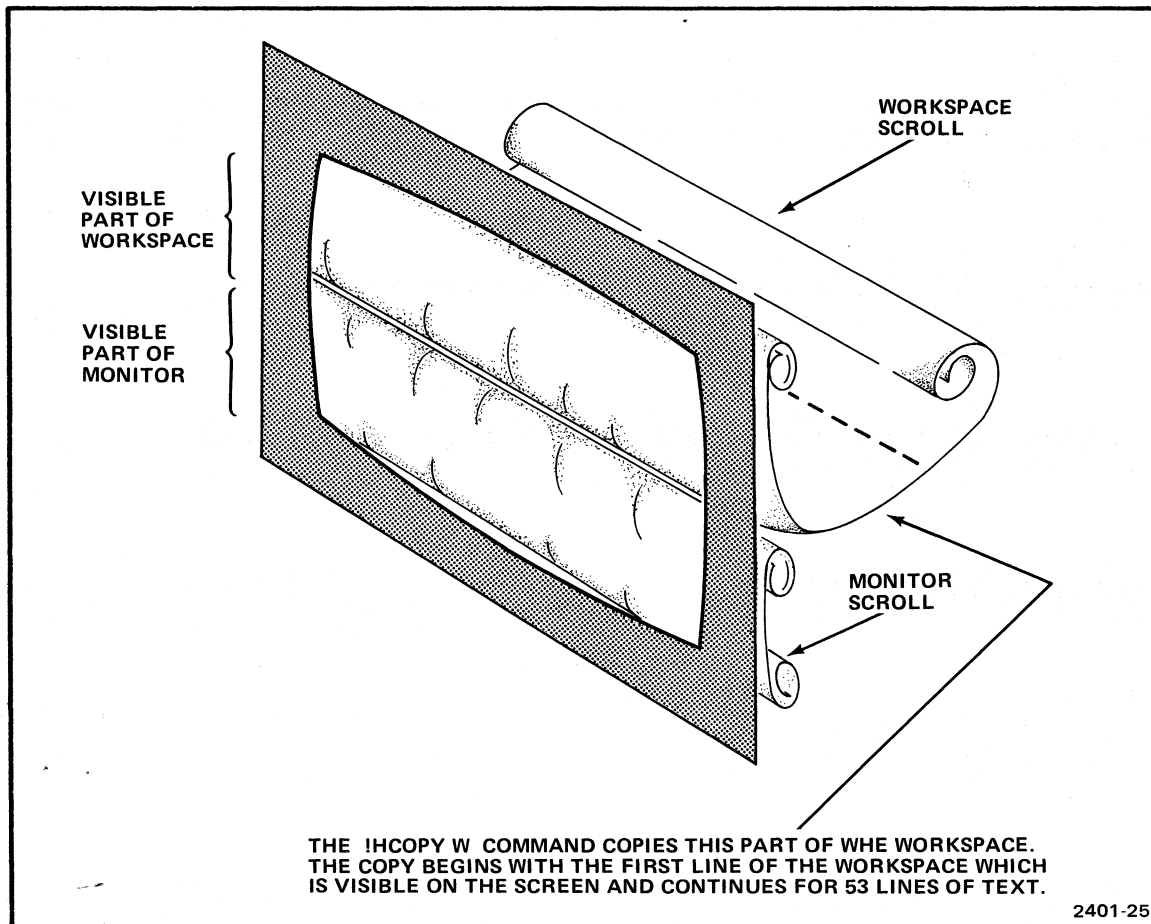

Fig. 7-2. Making a copy of text in the workspace.

You can copy more than one page from the workspace or monitor. To do this, type on the keyboard:

!HCO 2 W <CR>

or

!HCO 3 M <CR>

## MAKING HARD COPIES

In the first example, the 4025 copies 2 pages of text from the workspace. In the second example, it copies 3 pages from the monitor. The first page of copy starts with the first line of text displayed on the screen.

If you tell the 4025 to copy five pages of text from the workspace, and the workspace has only two and one half pages of text stored in it, the 4025 will give you three pages of hard copy. It will not waste hard copy paper by producing five pages, only three of which have any text on them. However, the HCOPY command will always produce at least one page of copy, even if there is nothing on that page.

If you leave out the S or W or M in typing the HCOPY command, the 4025 will copy from either the workspace or the monitor, depending on which of these is receiving text from the keyboard. For instance, if text from the keyboard goes to the monitor,

```
!HCOPY <CR> or !HCO <CR>
```

copies one page of the monitor. If the keyboard is typing into the workspace,

```
!HCOPY <CR> or !HCO <CR>
```

copies one page of the workspace.

(If the HCOPY command comes from the computer rather than the keyboard, the scroll into which the computer is typing is the one which is copied.)

## Copying on a Printer

If your 4025 is equipped with Option 3 (RS-232 Peripheral Interface), you can print the contents of the workspace on a TEKTRONIX 4642 Printer. Also, you can have the 4642 print text coming from the host computer.

To print the workspace contents on the 4642, check that the printer's SELECT light is on, and type this command:

```
!COPY W P <CR> or !COP W P <CR>
```

(If the 4642's SELECT light is off, press the SELECT key just below it to turn the light on.)

In the COPY command, W stands for workspace, and P for printer. The command tells the 4025 to copy the contents of the workspace onto the printer.

To direct text coming from the host computer to the 4642 Printer, type this command:

```
!COPY H P <CR> or !COP H P <CR>
```

(The H stands for "host computer"; this command tells the 4025 to copy text from the host computer onto the printer.)

The 4025 will continue to copy data from the host computer onto the printer until one of three things happens:

- The computer sends an *end-of-file string* to tell the 4025 to stop copying. (See the Programmer's Reference Manual for information on end-of-file strings.)
- The 4025, in buffered mode, receives a prompt string from the computer.
- The operator presses BREAK twice in quick succession.



# Section 8

## PERIPHERAL DEVICES

This section tells how to use the 4025 with its peripheral devices: printers (the 4642 Printer and others), the 4924 Digital Cartridge Tape Drive, and the 4662 Interactive Digital Plotter. Topics included are:

- Using the printer: copying text from the workspace or the host computer on the printer.
- Considerations when using devices (4924 Tape Drives or 4662 Plotter) which use the GPIB (General Purpose Interface Bus).
- Using the 4924 Tape Drive: installing it, copying files to and from it.
- Using the 4662 Plotter.
- Copying to and from the host computer.

### PRINTER

If Option 3 (RS-232 Peripheral Interface) is installed, you may attach an accessory printer, such as the TEKTRONIX 4642 Printer. You may print text from the 4025's workspace, the host computer, or a 4924 Tape Drive.

### Connecting the Printer to the 4025

Figure 8-1 shows the 4025 connected to a TEKTRONIX 4642 Printer. If Option 3 (RS-232 Peripheral Interface) is installed in the 4025, there is a cable with a female RS-232 connector emerging from the rear of the 4025's cabinet. Connect this cable to the male RS-232 connector on the cable coming from the 4642.

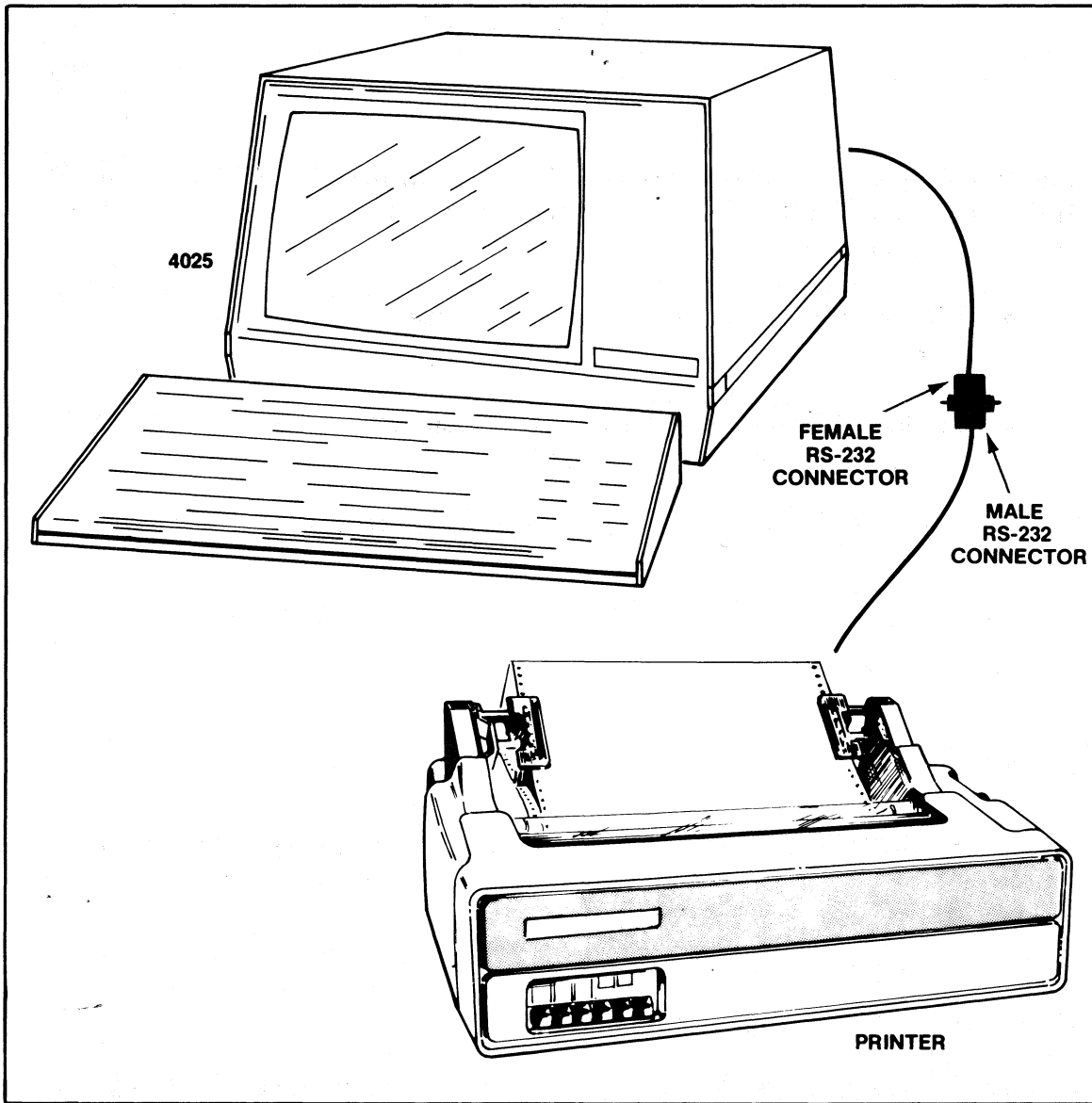

Figure 8-1. Connections to printer.

### Setting Switches on the 4642

Refer to Figure 8-2. Set the switches on the 4642 Printer as follows:

- POWER switch (on the rear panel) ON. (The POWER light above the LINE FEED switch should be on.)
- SELECT switch ON. (The SELECT light above the SELECT switch should be on.)



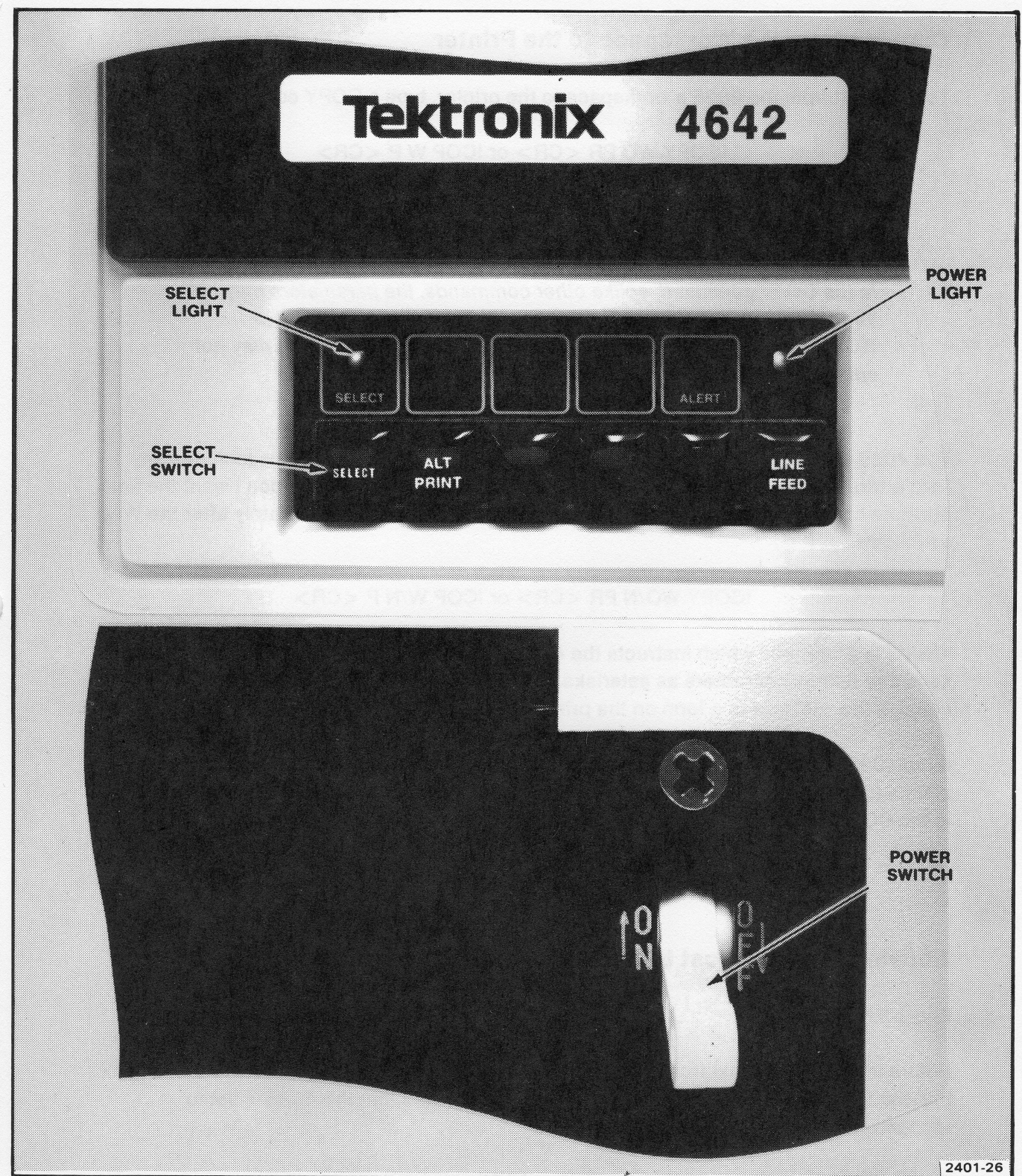

Figure 8-2. Switch settings on 4642 Printer.

## Copying from the Workspace to the Printer

To copy text from the 4025's workspace to the printer, type a COPY command:

!COPY WO PR <CR> or !COP W P <CR>

### NOTE

*In the COPY command, unlike other commands, the parameters may not be spelled out completely. That is, you may not spell out the word WORKSPACE, but must abbreviate it to WO or W. Likewise, you may not spell out the word PRINTER, but must abbreviate it to PR or P.*

The 4025 sends the entire contents of the workspace to the printer. This includes any field attribute codes, which are sent as ATTRIBUTE commands. If you don't want the field attribute codes printed, you can suppress them by adding a /N immediately after the WO, as follows:

!COPY WO/N PR <CR> or !COP W/N P <CR>

The /N is a "switch" which instructs the 4025 not to send field attribute codes and to send any rulings characters as asterisks. You would use the /N switch if you were copying the contents of a form on the printer.

If the 4025 is in form fillout mode, you may choose to copy only the contents of the form's blanks (unprotected fields) onto the printer. To do this, add a /U immediately after the WO in the COPY command:

!COPY WO/U PR <CR> or !COP W/UP <CR>

## Copying from the Host to the Printer

### End-of-File String

Before trying to copy text from a file in the host computer to the printer, you should check that the file's end is marked with an *end-of-file string*, and that the 4025 is set to recognize the same end-of-file string.

The end-of-file string is a string of up to ten ASCII characters marking the end of the text to be copied. To examine the 4025's end-of-file string, type the PERIPHERALS command:

!PERIPHERALS <CR> or !PER <CR>

The 4025 displays the PERIPHERALS list (Figure 8-3). The list's last line begins with the letters EOF: the characters shown after these letters comprise the current end-of-line string. (The 4025 comes from the factory with the end-of-line string set to *fraction bar, asterisk* as shown Figure 8-3.)

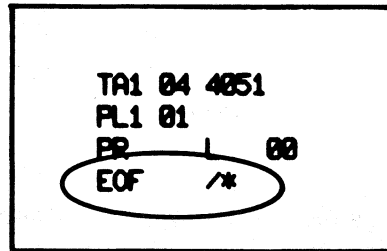

```

TA1 04 4051
FL1 01
PR | 00
EOF /*

```

Figure 8-3. PERIPHERALS message showing end-of-file string.

### Changing the End-of-File String

You can change the end-of-file string with an EOF command. In this command, you may enclose the new end-of-file string in quotes (or other delimiters described in the 4024/4025 Programmer's Reference Manual). Alternatively, you may specify the characters of the string by their ASCII decimal equivalents:

```
!EOF "ABCDE" <CR> or !EOF 65,66,67,68,69 <CR>
```

After changing the end-of-file string, be sure to check that you have set it correctly by typing the PERIPHERALS command.

### The COPY Command

Once you have checked that the file to be copied is marked with the correct end-of-file string, you are ready for the "copy from host to printer" command. *This command should be given from the host computer, and not typed on the keyboard.* (For instance, the COPY command and the end-of-file string could be incorporated in the host file to be copied.)

Suppose, for example, that you have the following text stored in a file in the host computer:

!COPY H PR

This is a test file to illustrate the 4025's "copy from host to printer" command (COPY HO PR or COP H P).

The file begins with the COPY command, on a line of its own. When the host computer sends that line to the 4025, it ends the line with "carriage return, line feed." The "carriage return" terminates the COPY command, causing the 4025 to begin the copy operation.

As the host computer sends the text following the COPY command, the 4025 copies that text on its printer. This continues until the end of the file, which is marked by the end-of-file string ("fraction bar, asterisk" in this example). The end-of-file string must be the very last thing in the file, as the 4025 uses this string to mark the end of the file; it will not copy anything after the end-of-file string.

/\*

You can tell the computer to send the file to the 4025. (The command to make the computer do this depends on the particular computer system being used.) When the computer sends the file, the COPY command at the start of the file causes the 4025 to copy the rest of the file on its peripheral printer. The copy ends with the end-of-file string (/\* in this example).

At the end of the COPY operation, the 4025 moves the printer paper to the start of a new page. It does this by sending several *line feed* characters. (If the printer is one that responds to *form feeds*, it may send a *form feed* character instead.)

The copying continues until one of three things happens:

- The computer sends an end-of-file string to tell the 4025 to stop copying.
- The 4025, in buffered mode, receives a prompt string from the computer. (See "Buffered Operation" in Section 3 of this manual.)
- You press the BREAK key twice in quick succession.

During a COPY from the host computer, the keyboard is disabled. You cannot type commands to the computer, although you can stop the COPY by pressing BREAK twice in quick succession.

Copying from the Tape Drive to the printer is described later in this section.

## Setting Printer Parameters

The 4025 comes from the factory correctly set for communicating with a TEKTRONIX 4642 Printer. With the SET command, you can change settings to permit the 4025 to use other printers. The settings you can change are:

- Whether the 4025 causes the printer to move its paper to the start of a new page by: (a) sending a series of ASCII *line feed* characters, or (b) sending an ASCII *form feed* character.
- The length of time that the 4025 waits, after sending one line of text, before it sends the next line. (This delay is to give the printer carriage time to return to the start of the next line.)

If the delay is set to zero, the 4025 examines one of the RS-232 circuits from the printer to see if the printer is ready to receive the next line of text. For instance, the 4642 Printer uses the RS-232 Data Terminal Ready circuit to signal its readiness for the next line of text.

The following examples show how to set these printer parameters:

!SET PR L <CR>	Makes the 4025 use <i>line feeds</i> when signaling the printer to move to the start of a new page.
!SET PR F <CR>	Makes the 4025 use the <i>form feed</i> character when signaling the printer to move to the start of a new page.
!SET PR 5 <CR>	Sets the 4025 to wait 5 tenths of a second after sending a line of text before sending the next line.
!SET PR 0 <CR>	Sets the 4025 not to wait a fixed period of time between lines of text, but to use "flag" signals (such as the RS-232 Data Terminal Ready signal) to determine when it may send the next line.
!SET PR L 0 <CR>	Sets the 4025 for use with a TEKTRONIX 4642 Printer — using <i>line feeds</i> rather than <i>form feed</i> to skip to the start of a new page, and using an RS-232 line to signal when a new line of text may be sent, rather than relying on a fixed delay between lines.

## GPIB DEVICES (4924 TAPE DRIVE, 4662 PLOTTER)

### Introduction

If the 4025 has Option 4 (GPIB Peripheral Interface<sup>1</sup>) installed, it can be connected to up to four TEKTRONIX 4924 Digital Cartridge Tape Drives, and to up to two TEKTRONIX 4662 Interactive Digital Plotters. Figure 8-4 shows one possible arrangement.



*When using GPIB devices (4924 Tape Drives or 4662 Plotters) with the 4025, be sure to turn them on before you start work with the 4025. That is, turn all the GPIB devices on, and then turn on the 4025. (If the 4025 is already on, press the MASTER RESET button.)*

*Leave all the Tape Drives and Plotters turned on while using the 4025. (Turning them off and on can send spurious signals on the GPIB that can interfere with the 4025's operation.)*

### Power-On Procedure

If any GPIB device is connected, use this procedure each time you turn on the 4025:

1. First, turn on *all* the Plotters and Tape Drives; then, turn on the 4025. (If the Plotters and Tape Drives are not turned on during the 4025's power-up sequence, the 4025 deletes them from its memory of attached devices.)
2. Type the PERIPHERALS command:

!PERIPHERALS <CR> or !PER <CR>

The 4025 displays its PERIPHERALS list in the monitor. (See Figure 8-5.) This list shows all the devices which the 4025 is aware are attached to it. In the list, TA1, TA2, etc., represent Tape Drives, PL1 and PL2 stand for Plotters, PR denotes the printer, and EOF names the end-of-file string.

<sup>1</sup>The General Purpose Interface Bus (GPIB) is a standard way of connecting programmable instrumentation. It is sometimes called the IEEE 488-1975 bus, after the standard (IEEE Std 488-1975) which specifies it.

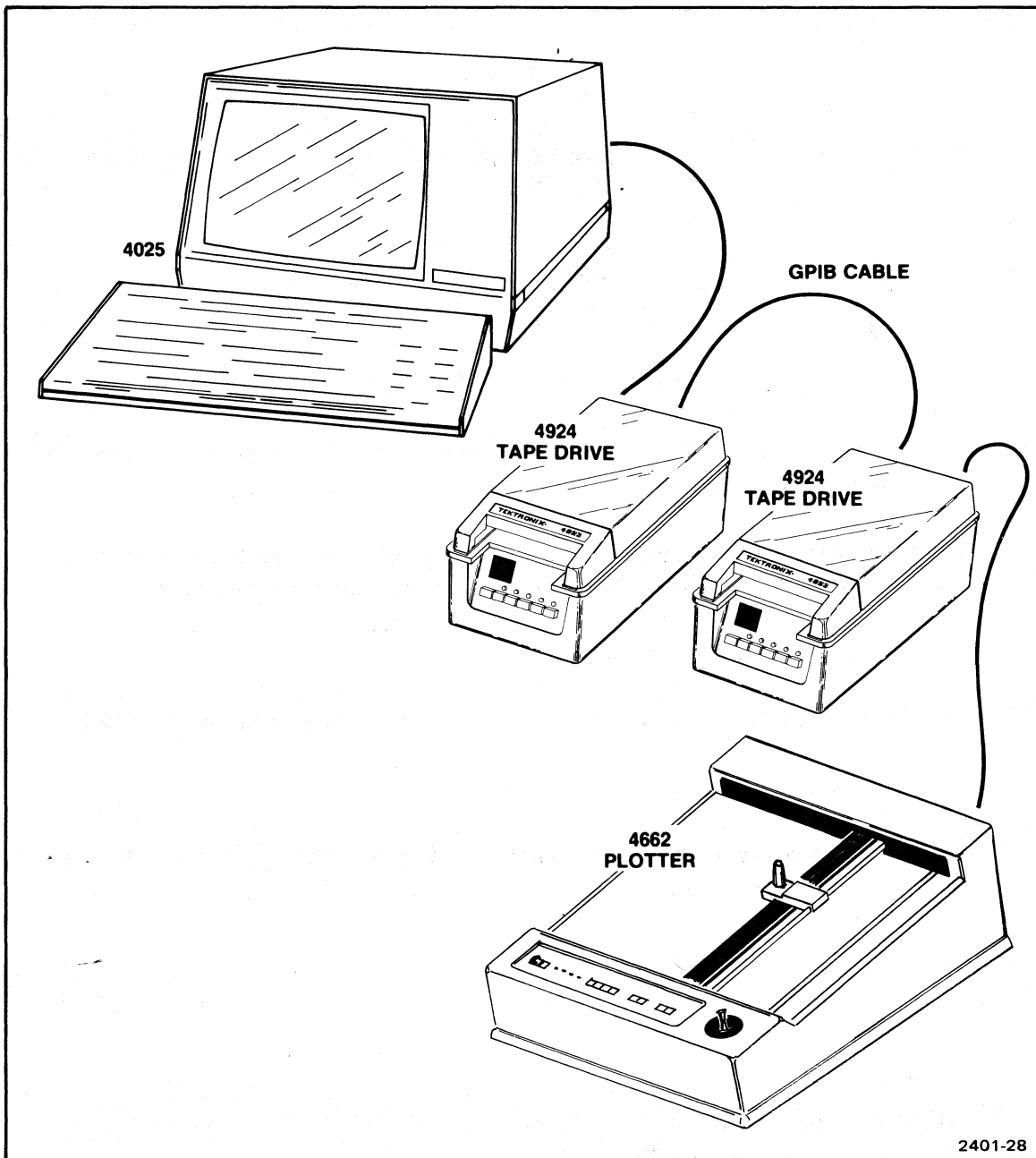

Figure 8-4. 4025 with GPIB peripheral devices.

## PERIPHERAL DEVICES

```
TA1 04 4051
TA2 06 4051
TA3 08 4051
TA4 08 4051
PL1 01
PL2 15
PR   L 00
EOF  /*
```

Figure 8-5. The PERIPHERALS list.

3. Check that the PERIPHERALS list includes all the Tape Drives and Plotters connected to the 4025. If a device is missing from the list, the reason may be:
  - You turned the 4025 on before turning on the device. At power-up (or MASTER RESET) the 4025 checked to see whether the device was there. When it got no response (because the device was then turned off), the 4025 deleted that device from its PERIPHERALS list.
  - The device is not turned on, or it has been disconnected from the 4025.
  - The device's switches are set incorrectly.
  - The 4025 has not been informed of the device's presence. That is, the device has not been named in a SET command. (The SET command is described later in this section.)

### NOTE

*If the 4025 has Option 3 (the RS-232 Peripheral Interface), the PERIPHERALS message includes a "PR" entry for the printer regardless of whether a printer actually is connected.*

4. If any of the Plotters and Tape Drives are missing from the PERIPHERALS message, perform the "Initialization Procedure," described later in this section.



## Initialization Procedure

Whenever you connect a GPIB device (Tape Drive or Plotter), perform the following installation procedure. The procedure serves these purposes:

- It gives the 4025 details about the device you have connected, so that it can later send appropriate commands to that device.
- It checks that the 4025 is able to communicate with the device.

The procedure is as follows:

1. Connect all the GPIB devices to the 4025, using the special GPIB cables. Set each device's switches as described later in "Installing the 4924" and "Installing the 4662."

This includes choosing a "GPIB address" for each device and setting its GPIB Address switches accordingly. In choosing the GPIB addresses, follow these rules:

- All addresses must be numbers between 1 and 30, inclusive. (Addresses of 0 and 31 are not allowed.)
  - No two devices may have the same GPIB address.
  - The GPIB address for a 4924 Tape Drive must be an even number in the range from 2 to 28. (Addresses 0 and 30 are not permitted.)
  - The GPIB address for a 4662 Plotter must not be the next higher address after a 4924 Tape Drive's GPIB address. (For instance, if a Tape Drive has GPIB address 6, you may not give GPIB address 7 to a Plotter. The next available address would be address 8.)
2. Turn on all the GPIB devices.
  3. Turn on the 4025; if it is already turned on, press MASTER RESET.

## PERIPHERAL DEVICES

- Using SET commands, tell the 4025 about each GPIB device that you have connected. The following are examples of SET commands, together with "translations" of what you tell the 4025 when type you them:

!SET TA1 4 4051 <CR> "Tape Unit 1 is connected at GPIB address 4. It will record data on its tape in a format compatible with the TEKTRONIX 4051 Graphic System."

!SET TA2 6 4923 <CR> "Tape Unit 2 is connected at GPIB address 6. It uses a tape format compatible with the TEKTRONIX 4923 Digital Cartridge Tape Recorder."

!SET TA3 8 <CR> "Tape Unit 3 is connected at GPIB address 8." (If you omit 4051 or 4923 from the SET command for a Tape Drive, the 4025 sets the Tape Drive to record data in 4051 format.)

!SET PL1 11 <CR> "Plotter 1 is connected at GPIB address 11."

- Type the PERIPHERALS command:

!PERIPHERALS <CR> or !PER <CR>

Examine the list which appears; it should agree with the SET commands you have just typed.

- Press MASTER RESET. (At this point, the 4025 checks to be sure that it can communicate with all the devices in the PERIPHERALS list.)
- Type the PERIPHERALS command again:

!PER <CR>

If a GPIB device is missing from the message, one of the following may be the reason:

- The device is not turned on, or it is not connected to the GPIB.
- The device's switches are set incorrectly.
- The device's SET command named the wrong GPIB address. (Or the SET command never was given.)

## 4924 TAPE DRIVE

If the 4025 has Option 4 ( GPIB Peripheral Interface), up to four TEKTRONIX 4924 Digital Cartridge Tape Drives may be connected to it. These Tape Drives provide local storage of large amounts of data.

One way to use the Tape Drives is to store data entered when filling out forms in the 4025's workspace. The first file on a tape might hold commands to create the form; later files might hold the data entered in form fillout mode. Once all the data is entered, you may copy it from the Tape Drive to the host computer.

Another way to use the Tape Drive is to store pages of text which have been typed and edited in the workspace. Each page may be stored in a separate tape file, to be recalled for later editing if desired. At the end of a day's work, the text may be copied from the tape drive to the host computer.

In both these examples, the 4025's ability to store and edit data locally is used to save charges for computer connect time.

### Installing the 4924

To install the 4924, you must connect it to the 4025 by means of the special GPIB cable, set its switches correctly, and inform the 4025 of its presence. Use this procedure:

1. Connect the special GPIB cable coming from the rear of the 4025 to the GPIB connector on the rear of the 4924, as shown in Figure 8-6. If this cable is already connected to another Tape Drive or Plotter, use another GPIB cable, stacking one end of that cable on the other cable's connector. Up to four Tape Drives and two Plotters may be connected in this way.
2. Refer to Figure 8-7. Set the ALT-4051 switch on the 4924's rear panel to ALT.
3. Choose a GPIB address for the 4924. In choosing the address, follow these rules:
  - The GPIB address must be an even number in the range from 2 to 28, inclusive. (Addresses 0 and 30 are not allowed.)
  - The GPIB address must be different from that of any other GPIB device (Tape Drive or Plotter) connected to the 4025.

## PERIPHERAL DEVICES

- If any Plotter has an odd number as its GPIB address, the 4924's GPIB address may not be the next lower-numbered address. For instance, if a Plotter connected to the 4025 has GPIB address 7, the 4924 Tape Drive may not have GPIB address 6. (It might, however, be given a GPIB address of 4 or 8.)

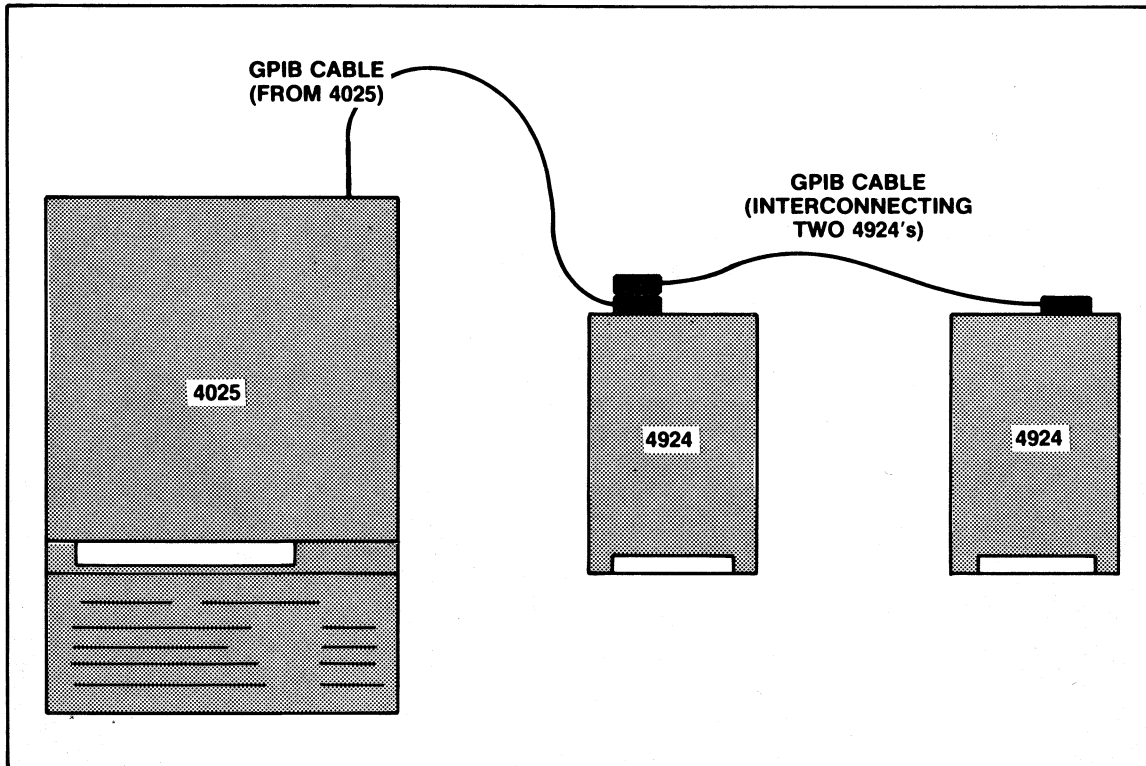
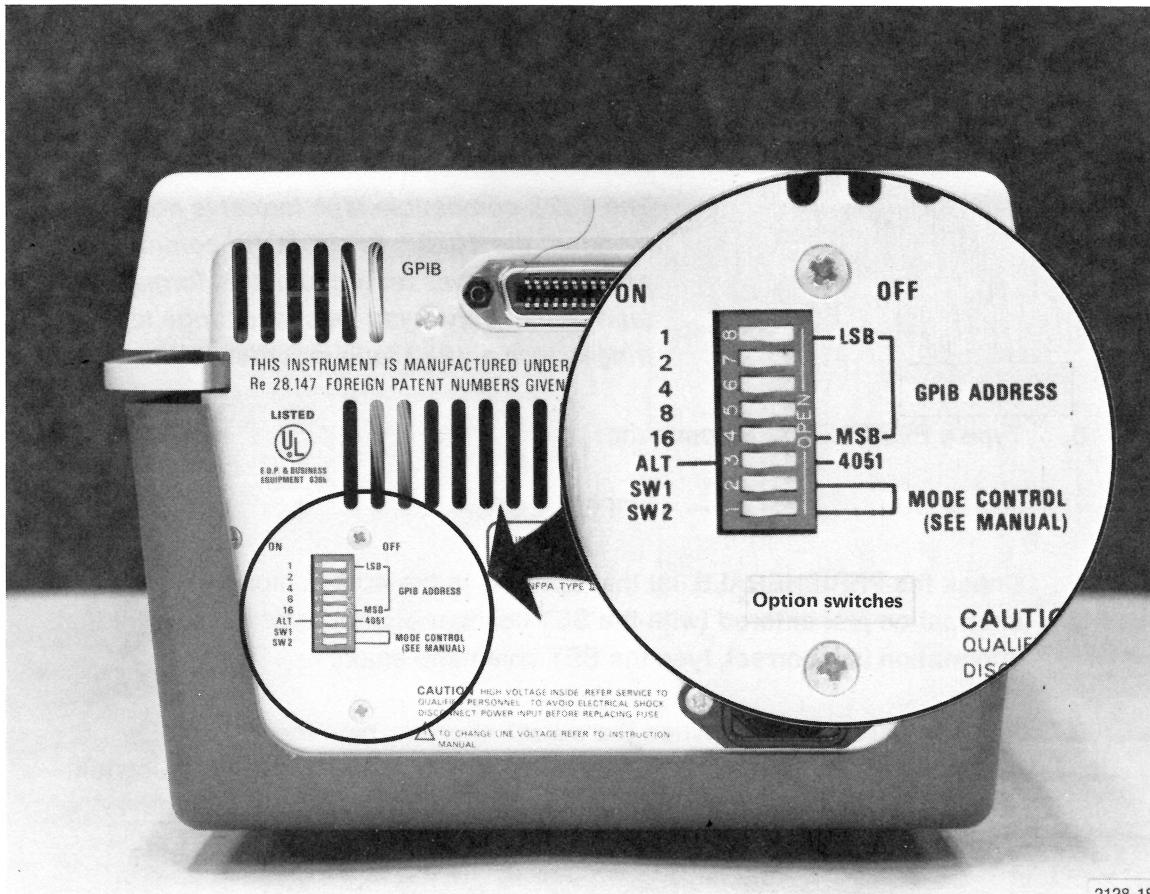

Figure 8-6. GPIB interconnections.

4. Encode the GPIB address you have selected on the 4924's GPIB ADDRESS switches (Figure 8-7), as follows:

GPIB Address	16	8	4	2	1
2	OFF	OFF	OFF	ON	OFF
4	OFF	OFF	ON	OFF	OFF
6	OFF	OFF	ON	ON	OFF
8	OFF	ON	OFF	OFF	OFF
10	OFF	ON	OFF	ON	OFF
12	OFF	ON	ON	OFF	OFF
14	OFF	ON	ON	ON	OFF
16	ON	OFF	OFF	OFF	OFF
18	ON	OFF	OFF	ON	OFF
20	ON	OFF	ON	OFF	OFF
22	ON	OFF	ON	ON	OFF
24	ON	ON	OFF	OFF	OFF
26	ON	ON	OFF	ON	OFF
28	ON	ON	ON	OFF	OFF



2128-18

Figure 8-7. 4924 rear panel switches.

## PERIPHERAL DEVICES

5. Depress the red ON LINE switch on the 4924's front panel. Turn its POWER switch ON.
6. Turn the 4025 on. If it is already on, press MASTER RESET.
7. When the cursor appears, type a SET command to inform the 4025 of the Tape Drive's presence:

!SET TA1 4 <CR>  
or  
!SET TA1 4 4051 <CR>

"A 4924 has been connected as Tape Unit 1 at GPIB address 4. It will record data on its tape in a format compatible with the TEKTRONIX 4051 Graphic System's internal tape drive."

!SET TA2 6 <CR>

"A 4924 is connected as Tape Unit 2 at GPIB address 6. It records data in 4051-compatible format."

!SET TA3 8 4923 <CR>

"A 4924 is connected as Tape Unit 3 at GPIB address 8. It records data in a format compatible with the TEKTRONIX 4923 Digital Cartridge Tape Recorder."

### NOTE

*The 4923-compatible tape format is not recommended; the 4025's DIRECTORY command does not work for tapes recorded in this format. Use 4923 tape format only if you must exchange tape cartridges with a 4923 tape recorder.*

8. Type a PERIPHERALS command:

!PER <CR>

Check the PERIPHERALS list that appears in the 4025's monitor. The information just entered (with the SET command) should be included. If that information is incorrect, type the SET command again.

9. Press MASTER RESET. When the cursor appears, type the PERIPHERALS command again. Check the PERIPHERALS message; if the information just entered with the SET command is missing, you have not installed the 4924 correctly.

## Allocating Files

Before you can record data on the 4924's tape cartridge, you must create files on that tape to hold the data. For this, use the ALLOCATE command. In the ALLOCATE command, you tell the 4025 four things about the files to be created:

- On which tape unit to create the files.
- The file number of the first file to be created. (File number zero causes the 4924 to rewind to the start of the tape and number the first file created as file number one.)
- How many files are to be created.
- How large the files are to be. (If you specify 5000 characters in the ALLOCATE command, each file will be large enough to hold at least 5000 characters of data.)

Figure 8-8 illustrates an ALLOCATE command. The following exercise gives practice using the ALLOCATE command, and also introduces the DIRECTORY command.

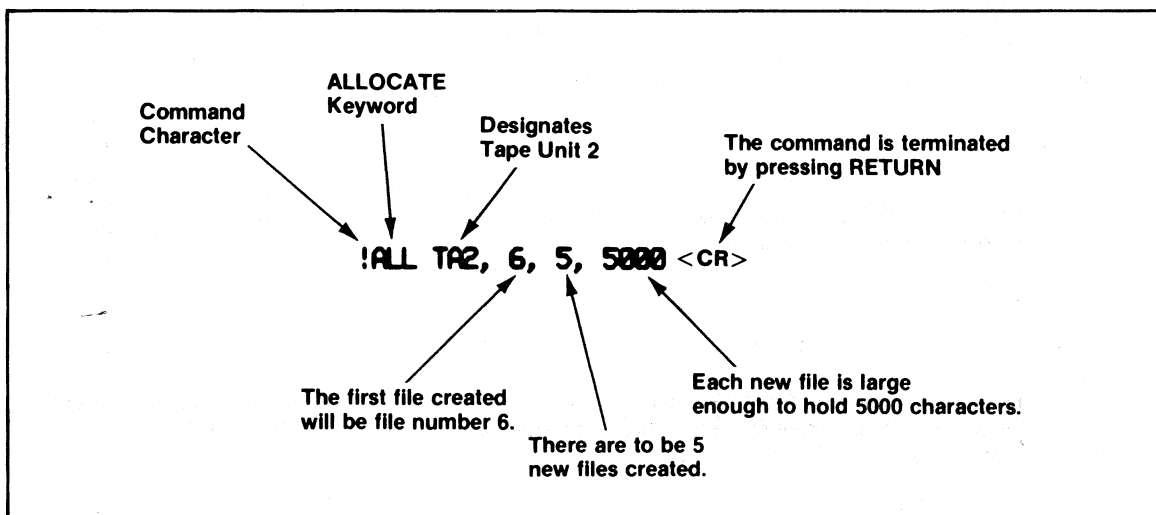

Figure 8-8. ALLOCATE command.

## PERIPHERAL DEVICES

### Exercise

1. Install a 4924 Tape Drive, if one is not already installed. Press MASTER RESET. When the cursor appears, type:

**!PER <CR>**

2. Check that the tape unit is listed in the PERIPHERALS list that appears. You should see a line in the PERIPHERALS message like this:

**TA1 4 4051**

(This says that Tape Unit 1 is at GPIB address 4, and that it writes data on its tape in "4051 format.")

3. If 4923 appears in the PERIPHERALS message instead of 4051, type a SET command to change the tape unit to record in 4051 format. Be sure to use the same GPIB address in the SET command as the PERIPHERALS message currently shows for that tape unit.

For instance, if the PERIPHERALS message says:

**TA1 4 4923**

you should type:

**!SET TA1 4 4051 <CR>**

Type the PERIPHERALS command again; you should now see:

**TA1 4 4051**

4. Insert an unused tape cartridge in the 4924.

### NOTE

*Don't use a cartridge holding data you want to keep; you will destroy any data on the tape when you create new tape files.*

5. Type this command:

**!ALLOCATE TA1 0 5 1000 <CR>**

The 4924 rewinds to the beginning of its tape and then marks off (creates) five files on the tape. It also creates a dummy file (file 6) to reserve a place for later ALLOCATE commands.

6. Type the following:

**IDIRECTORY TA1 <CR>**

The 4025 lists in its monitor a directory of the files on the tape.

1	NEW	4
2	NEW	4
3	NEW	4
4	NEW	4
5	NEW	4
6	LAST	3



In this exercise, you created five new tape files. Each file holds 4 “physical records” (indicated by the number 4 in the tape directory’s rightmost column). Each of these records can hold 256 characters, so files 1 to 5 can each hold as many as 1024 characters — a little more than the 1000 characters specified in the ALLOCATE command.

In addition to the five files requested, file 6 was placed on the tape and labeled LAST. You cannot record data in this file; its only purpose is to reserve a place where later ALLOCATE commands may create more new files.

To allocate an additional five files, each large enough to hold 2000 characters, you could type:

```
!ALL TA1 6,5,2000 <CR>
```

The new files created would then start with file 6 (previously marked LAST), and would appear in a later DIRECTORY message as files 6 through 10. (File 11 would then be marked LAST to reserve a place for later ALLOCATE commands.)

#### NOTE

*When you use an ALLOCATE command to create new files on a tape cartridge, any data on files at or after the files you create is lost. For instance, if you create files 2 and 3 with an ALLOCATE TA1,2,2,100 command, any data at files 2, 3, 4, 5, etc., is lost.*

The following are examples of the ALLOCATE command:

```
!ALL TA1,0,5,5000 <CR>
```

On Tape Unit 1, finds “file zero” (the beginning of the tape). Starting from there, creates 5 files, each large enough to hold at least 5000 characters of data. Also creates a dummy file (file 6) to reserve a place for a later ALLOCATE command to create more files.

```
!ALL TA1,6,2,100 <CR>
```

On Tape Unit 1, finds file 6 and positions the tape head at the start of that file. Then creates files 6 and 7, each capable of holding at least 100 characters of data. Creates a dummy file (file 8) to reserve a place for a later ALLOCATE command to create more files.

## The DIRECTORY Command

You have already used the DIRECTORY command:

!DIR TA1 <CR>                      Sends a tape directory for Tape Unit 1 to the 4025's monitor.

If you wish, you may specify in a DIRECTORY command that the tape directory is to go to the host computer or to the 4642 Printer:

!DIR TA2 PR <CR>                      Sends a tape directory for Tape Unit 2 to the printer.

!DIR TA3 HO <CR>                      Sends a tape directory for Tape Unit 3 to the host computer.

Besides the monitor, the printer and the host computer are the only devices to which you can send a tape directory.

### NOTE

*The DIRECTORY command works only if the tape unit uses 4051 format for recording data. If the tape unit is set for 4923 format, a DIRECTORY command produces this message:*

*TA1 DEV ERR 04*

## The COPY Command: Copying to and from the Tape Drive

The COPY command transfers data to, from, or among the 4025's peripheral devices. This command takes the following form:

!COPY <source> <destination> <CR>

where, <source> and <destination> are replaced by the following abbreviations:

WO or W                      The 4025's workspace.

HO or H                      The host computer.

PR or P                      The 4642 Printer.

TA1 or TA or T	Tape Unit 1.
TA2, TA3, TA4	Tape Units 2, 3 and 4.
PL1 or PL	Plotter 1.
PL2	Plotter 2.

If the <source> or <destination> is a particular file on a 4924 Tape Drive, it is indicated by the abbreviation for that tape unit, followed immediately by a period and the file number:

TA1.1	Tape Unit 1, file 1.
TA2.16	Tape Unit 2, file 16.

If you have previously designated a particular tape file in a COPY command, you may, in a later COPY command, access the *next* file on the same tape unit *without* naming that particular tape file, but naming only the tape unit. For example, consider this sequence of commands:

```
!COPY TA1.1 WO <CR>
!COPY TA1 WO <CR>
!COPY TA1 WO <CR>
!COPY TA1 WO <CR>
```

The first command copies Tape Unit 1, file 1 to the workspace. The next command copies Tape Unit 1's next file (file 2) to the workspace. Likewise, the third and fourth commands copy Tape Unit 1, files 3 and 4 to the workspace.

This "automatic incrementing" feature permits you to access successive tape files by repeatedly pressing a function key which has been programmed to mean !COPY TA1 WO (or !COPY WO TA1). For instance, the first file of a tape might contain a command file to: (a) create a form in the workspace, (b) program the SEND key to mean "copy the contents of the workspace to next tape file," and (c) put the 4025 in form fillout mode. You would invoke the form by typing !COPY TA1.1 WO. Thereafter, each time you pressed the SEND key, a !COPY WO TA1 command would copy the contents of the form onto the next tape file.

## PERIPHERAL DEVICES

The following examples show how to transfer data to and from a 4924 Tape Drive.

!COP WO TA1.1 <CR>

Copies the contents of the workspace to Tape Unit 1, file 1. The previous contents of that file are destroyed.

If no workspace is currently defined, copies an "empty workspace" into the file. This has the effect of erasing the file.

!COP TA1.1 W <CR>

Copies the contents of Tape Unit 1, file 1, to the 4025's workspace.

If no workspace is currently defined, the contents are displayed in the monitor.

!COP H TA2.3 <CR>

Copies data coming from the host computer to Tape Unit 2, file 3. Copy terminates when one of these things happens:

- An end-of-file string is received from the host computer.
- A prompt string is received with the 4025 in buffered mode.
- BREAK is pressed twice in quick succession.

### NOTE

*The keyboard is disabled during a COPY from the host computer. Consequently, this command should only be issued by the host computer, not typed on the keyboard.*

**/N and /U Switches**

When copying from the workspace to a tape file, the 4025 sends the entire contents of the workspace, including field attribute codes, which are encoded as ATTRIBUTE commands. You may, however, suppress these field attribute codes by using the /N switch:

!COP WO/N TA1.5 <CR>      Copies the contents of the workspace to Tape Unit 1, file 5. Does not copy field attribute codes.

If the 4025 is in form fillout mode, you may choose to send only the contents of the form's blanks (unprotected fields). To do this, use the /U switch:

!COP WO/U TA1.5 <CR>      Takes, from a form in the workspace, the contents of the form's blanks (unprotected fields), and records them on Tape Unit 1, file 5.

If the contents of a tape file includes a list of commands for the 4025, the 4025 will execute the commands when you copy the tape file to the 4025's workspace:

!COP TA1.1 WO <CR>      Retrieves the list of commands in Tape Unit 1, file 1, and causes the 4025 to execute those commands.

You may, however, retrieve the contents of a command file *without* causing the 4025 to execute the commands. (For instance, you might place the command file in the workspace for editing.) To copy a command file to the workspace *without* executing the commands in the file, use the /N switch:

!COP TA1.1 WO/N <CR>      Copies Tape Unit 1, file 1, to the workspace. Does not execute any commands in the file.

**NOTE**

*The WO/N switch has different meanings depending on whether it represents a COPY command's source or destination.*

*When copying from the workspace, WO/N means "don't copy any field attribute codes."*

*When copying to the workspace, WO/N means "don't execute any of the commands being copied."*

### The KILL Command

When the 4924 records data in "4051 tape format" (its normal data format), each tape file begins with a *header record*. The header record holds the information about the file which you see when you ask for a tape directory (give the DIRECTORY command). When you first create a file, its header is marked NEW; it is changed to ASCII DATA when you record data in the file.

You can, if you wish, restore a file to its NEW status with the KILL command. For instance:

```
!KILL TA1.6 <CR>
```

"kills" Tape Unit 1, file 6. The header for that file is marked NEW and any data that was recorded there is lost.

### 4924 Error Messages

If you command the 4025 to do something impossible, it will usually display an error message. Table 8-1 lists the error messages you may encounter when using the 4025 with a 4924 tape drive.

Table 8-1

4924 TAPE DRIVE ERROR MESSAGES	
Message	Error
BUSY	The GPIB is busy; you may not use it just now.
TA1 NO DEV	You have tried to access TA1 (Tape Unit One), but it is not in the 4025's PERIPHERALS list.
TA1 FIL NAM ERR	You have made an error in naming the tape drive as the <source> or <destination> in a command. You may have attached an illegal switch to TA1 in command, or mistyped the file specification (TA1,6 instead of TA1.6).
TA1 DEV ERR 01	Domain Error or Invalid Argument.
TA1 DEV ERR 02	File Not Found.
TA1 DEV ERR 03	Magnetic Tape Format Error.

Table 8-1 (cont)

Message	Error
TA1 DEV ERR 04	Illegal Access.
TA1 DEV ERR 05	File Not Open.
TA1 DEV ERR 06	Read Error.
TA1 DEV ERR 07	No Tape Cartridge Inserted.
TA1 DEV ERR 08	Over-Read. (More than 256 characters in the 4924's buffer.)
TA1 DEV ERR 09	Tape is Write-Protected.
TA1 DEV ERR 10	Read-After-Write Error.
TA1 DEV ERR 11	End of Tape.
TA1 DEV ERR 12	End of File.

## 4662 PLOTTER

If the 4025 has Option 4 ( GPIB Peripheral Interface), it may be connected to one or two TEKTRONIX 4662 Interactive Digital Plotters. The 4662 Plotter takes its commands in a different format than does the 4025; however, the 4025 can translate its own graphics commands (VECTOR, STRING, etc.) into plotter commands. This permits the following:

- The host computer may send a series of graphics commands in "4025 language" to make the 4025 draw a graph. As it draws the graph, the also translates the commands into "plotter language" and sends them to the Plotter, making the Plotter draw the same graph.
- The host computer may compose a series of graphics commands (in either "4025 language" or "plotter language") to cause the Plotter to draw a certain graph. Then the host may send these commands to the 4025 for recording on a tape file. Later, the 4025 may "play the file back" — copy the graphics file from the Tape Drive to the Plotter. As the file is played back, the Plotter draws the specified graph.

- You may compose a series of commands for the Plotter, typing them into the workspace and editing them with the editing keys. These may be in either "4025 language" or "plotter language." When you have the list of commands prepared, you can copy that list onto a 4924 tape file. Later, you can copy this "command file" from the Tape Drive to the Plotter. This causes the Plotter to execute the commands and draw the graph they specify.

### Installing the 4662

When installing a 4662 Interactive Digital Plotter, follow this procedure:

1. Set the Plotter on the table where it will be used, and connect its power cord to the power mains. Do not turn on the Plotter yet.
2. Choose a GPIB address for the Plotter. In doing so, follow these rules:
  - No two GPIB devices (Tape Drives or Plotters) may have the same GPIB address.
  - The Plotter's GPIB address must be in the range from 1 to 30; addresses 0 and 31 are not allowed.
  - The Plotter's GPIB address must not be the next address after a tape drive's address. For instance, if Tape Unit 1 is at GPIB address 4, you may not choose GPIB address 5 for the plotter.
3. Set the Plotter's rear-panel switches (Figure 8-9), as indicated in Table 8-2.
  - Switch A determines these things:

Whether the Plotter draws at half its normal speed ("low plotting speed"). The low plotting speed is for use with pens whose ink does not flow rapidly enough to use the Plotter's full speed.

Whether the Plotter responds to "carriage return" characters by advancing to a new line (CR,LF), or only by moving the pen to the left end of the current line (CR).

- Switch B (together with Switches A and C) configures the Plotter for use with the 4025.
- Switches C and D set the Plotter's GPIB address.



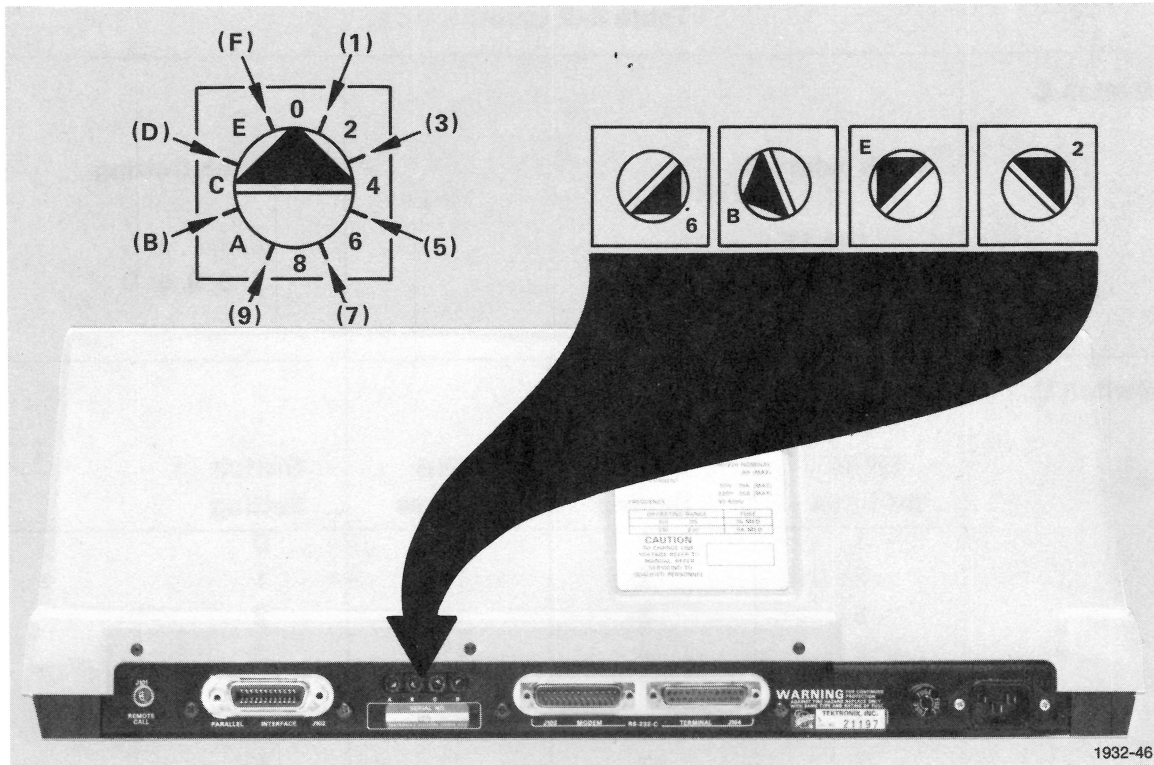

Figure 8-9. Plotter switch positions and locations.

Table 8-2

**SWITCH SETTINGS FOR 4662 PLOTTER**

Switch A	Low Plotting Speed?	CR Effect Setting	Switch
	NO	CR	0 or 4
	NO	CR,LF	1 or 5
	YES	CR	8 or C
	YES	CR,LF	9 or D
Switch B	Set switch B to either 4 or 5.		

Table 8-2 (cont)

<b>Switch C</b>	<b>GPIB Address</b>			<b>Switch Setting</b>
	1 to 15 16 to 30			0, 4, 8, or C 1, 5, 9, or D
<b>Switch D</b>	<b>GPIB Address</b>	<b>Switch Setting</b>	<b>GPIB Address</b>	<b>Switch Setting</b>
	1	1	16	0
	2	2	17	1
	3	3	18	2
	4	4	19	3
	5	5	20	4
	6	6	21	5
	7	7	22	6
	8	8	23	7
	9	9	24	8
	10	A	25	9
	11	B	26	A
	12	C	27	B
	13	D	28	C
	14	E	29	D
	15	F	30	E

4. Attach the GPIB cable to the Plotter, and be sure the Plotter's LOCAL switch is not depressed. Turn on the Plotter's POWER switch.
5. Turn the 4025 on. If it is already on, press MASTER RESET. (This clears the GPIB bus of any spurious signals which may have occurred as you turned on the Plotter.)
6. Type a SET command to inform the 4025 that you have connected the Plotter:

!SET PL1 5 <CR>            "Plotter 1 has been connected to the 4025; it has GPIB address number 5."

!SET PL2 6 <CR>            "Plotter 2 is connected at GPIB address 6."

7. Type the PERIPHERALS command and check that the information just entered with the SET command appears in the PERIPHERALS message:

!PER <CR>

If the information appears incorrectly, repeat step 6.

8. Press MASTER RESET. The 4025 checks to be sure that it can access all the devices in its PERIPHERALS list. It deletes from the list any device it cannot access.
9. Type the PERIPHERALS command again to be sure the Plotter still appears in the PERIPHERALS list.

## Operating Considerations

When using the 4662 Plotter:

- Never use the CALL button. (It sends a signal to which the 4025 is not prepared to respond.)
- Don't use the LOCAL button. (When it is depressed, the Plotter is effectively disconnected from the 4025.)
- The LOAD button is used only when loading paper; be sure to release it when the paper is loaded. (With LOAD depressed, the Plotter does not respond to commands.)
- Always turn on the Plotter, and any other Plotters and Tape Drives, before turning on the 4025 or pressing MASTER RESET. (If the Plotter is turned off when you press MASTER RESET or turn on the 4025, it is deleted from the 4025's PERIPHERALS list.)

To learn how to install paper in the Plotter, change its pen, position the boundaries of the plotting area, etc., see the 4662 Interactive Digital Plotter User's Manual.

## Passing Commands to the Plotter

Ultimately, the Plotter takes its commands in "plotter language" — strings of ASCII characters. These plotter commands are in a different format from the 4025's commands; they do not use the command character, and they may include ASCII control characters (especially ETX, the End-of-Text character).

There are two ways you may send commands to the Plotter:

- You can compose a list of plotter-language commands and COPY that list to the Plotter.
- You can compose a list of “4025-language” graphics commands. The 4025 can then send that list to the Plotter, translating into plotter language as it does so. This causes the Plotter to draw the graph specified by the commands in the list.

(Since the list is in 4025 language, it can also be used to draw the same graph in the 4025’s workspace.)

### Plotter-Language Commands

Table 8-3 gives examples of “plotter language” commands. The exercise following Table 8-3 shows how to prepare a command file using these commands and how to send that file to the Plotter. For a more complete list of plotter commands, see Appendix E.

Table 8-3

---



---

#### EXAMPLES OF 4662 PLOTTER COMMANDS

---



---

In the following examples, <ETX>, <CR>, and <LF> represent the ASCII *End-of-Text*, *Carriage Return*, and *Line Feed* characters.

Command	Effect
PThis is a test.<ETX>	Prints on the Plotter all characters after the P and before the <ETX>. In this case, prints “This is a test.”
PThis is line 1. <CR> <LF> This is line 2. <ETX>	Prints two lines of text as follows: This is line 1. This is line 2.
M50,63.537 <CR> or M 50,63.537 <CR>	Lifts the pen and moves it to the point X=50, Y=63.537 in the plotter’s system coordinates.

Table 8-3 (cont)

Command	Effect
	<p style="text-align: center;"><b>NOTE</b></p> <p><i>In its "move" and "draw" commands, the Plotter uses a system of coordinates which runs from 0 to 150 in the horizontal direction (x-direction) and from 0 to 100 in the vertical direction (y-direction).</i></p>
D100,100 <CR> or D 100,100 <CR>	Draws a line from the present pen position to the point X=100, Y=100 (Plotter coordinates).
D50,50,125,75,0,0 <CR> or D 50,50 125,75 0,0 <CR>	Draws a line from the present pen position to the point (50,50); from there, to the point (125,75); and from there, to the point (0,0).

#### Exercise

1. Create a workspace, and direct text from the keyboard to that workspace:

!WOR 20 K <CR>

2. Program Function Key 1 to mean: Enter snoopy mode, type the End-of-Text character, and exit snoopy mode<sup>2</sup>. To do this, you may use the LEARN key, as described in Section 3, or the LEARN command, as follows:

!LEARN F1 "ISNOOPY;" ,3, "ISNOOPY NO" ,13 <CR>

This enters plotter commands into the workspace, including ETX (End-of-Text) characters. To enter the ETX characters, the 4025 must be in snoopy mode. (Control characters have no effect in the workspace unless the 4025 is in snoopy mode.) The programmed key makes it easy to enter ETX characters: a single keystroke puts the 4025 in snoopy mode, enters an ETX character, and removes the terminal from snoopy mode.

<sup>2</sup>Snoopy mode, the SNOOPY command, and the LEARN command are described in the 4024/4025 Programmer's Reference Manual. These commands are primarily of interest to the person who programs the host computer to communicate with the 4025. This particular example of the LEARN command is included here because it provides the easiest way to insert End-of-Text characters into the workspace. For more information on the SNOOPY and LEARN commands, see the 4024/4025 Programmer's Reference Manual.

## PERIPHERAL DEVICES

3. Type the following plotter-language commands into the workspace. (Wherever <ETX> occurs in this list, press Function Key 1.)

```
M 2,2
PThis is the boundary of the plot.<ETX>
M 0,0
D 150,0 150,100 0,100 0,0
M 55,40
PThis is a triangle.<ETX>
M 10,10
D 140,10 75,90 10,10
```

You now have a "command file" of plotter language commands in the workspace.

4. Load paper into the Plotter, insert a pen, and uncap the pen. (These procedures are described in the 4662 Interactive Digital Plotter User's Manual.)
5. Send your command file from the workspace to the Plotter:

```
!COPY WO PL1 <CR>
```

The Plotter executes the plotter-language commands sent from the workspace.

6. If you have a 4924 Tape Drive installed, send the same command file to a file on the Tape Drive. For instance, if Tape Unit 1, file 1 is not holding data you want to keep, you may send the command file there:

```
!COPY WO TA1.1 <CR>
```

7. Now copy the command file from the Tape Drive to the Plotter:

```
!COPY TA1.1 PL1 <CR>
```

The Plotter executes the commands in the file, drawing the same diagram again.

### 4025-Language Commands for the Plotter

The preceding exercise shows how to create and use plotter-language command files. However, plotter language has some disadvantages:

- Since the 4025 does not understand plotter commands, it cannot use a command file written in plotter language to draw graphs in its workspace.
- The "print" command in plotter language must end with an ASCII ETX (End-of-Text) character; however, it is not always feasible to send control characters, like ETX, to a host computer. (The computer may use the control characters for other purposes, and not permit them to occur in ordinary strings of text.)

You can overcome these limitations of plotter language by writing your command files in "4025 language" and letting the 4025 translate them into plotter language when it sends them to the Plotter.

- Since the 4025 understands its own commands, you can use a command file written in 4025 language to draw a graph in the 4025's workspace as well as on the Plotter.
- Files of 4025 language commands can easily be sent to and from a host computer. (They do not have special control characters like ETX.)

The following exercise shows how to create and use 4025 language command files.

#### Exercise

To do this exercise, you need a Plotter ("PL1" in the PERIPHERALS list), and a Tape Drive ("TA1").

1. Create a workspace, and direct text from the keyboard to that workspace:

**!WOR 20 K <CR>**

2. Press the **COMMAND LOCKOUT** key; this turns on the **COMMAND LOCKOUT** light and stops the 4025 from responding to commands. This lets you type a list of 4025 commands into the workspace and edit them there.

3. Enter the following commands:

```
!WORKSPACE 20 K<CR>
!GRAPHICS 1,35<CR>
!VECTOR 23,14<CR>
!STRING "This is the boundary of the plot."<CR>
!VECTOR 0,0 639,0 639,479 0,479 0,0<CR>
!VECTOR 235,192<CR>
!STRING "This is a triangle."<CR>
!VECTOR 43,48 598,48 320,432 43,48<CR>
```

4. Press **COMMAND LOCKOUT** again to remove the 4025 from **COMMAND LOCKOUT** mode.
5. Tell the 4025 to send the contents of the workspace to an unused tape file. For instance, if Tape Unit 1, file 6, is not being used, type:

**!COPY WO TA1.6 <CR>**

## PERIPHERAL DEVICES

6. Now copy the file back to the 4025:

**!COPY TA1.6 WO <CR>**

As the 4025 receives the commands stored on the tape file, it executes them, drawing a diagram like that in Figure 8-10.

7. Erase the workspace (press the ERASE key), and copy the file again from the tape drive. This time, use the /N switch to suppress execution of the commands:

**!COPY TA1.6 WO/N <CR>**

This puts the file back in the workspace, where you may edit it with the editing keys. To do such editing, you would use this procedure:

- a. Press **COMMAND LOCKOUT**. With the 4025 in **COMMAND LOCKOUT** mode, you can type new commands into the workspace without having them immediately executed.
  - b. Edit the file: insert, change, delete commands as you wish.
  - c. When you are finished, remove the 4025 from **COMMAND LOCKOUT** mode. (Press the **COMMAND LOCKOUT** key again.)
  - d. Send the file back to the Tape Drive with a **COPY** command.
8. Have the 4025 copy the command file from the Tape Drive to the Plotter, translating the commands into plotter language as it does so. To do this, type:

**!COPY TA1.6/P PL1 <CR>**

(The /P is a switch instructing the 4025 to take commands coming from TA1.6 and translate them to plotter language before sending them to the Plotter.)

As the Plotter receives the translated commands, it draws the figure they describe.



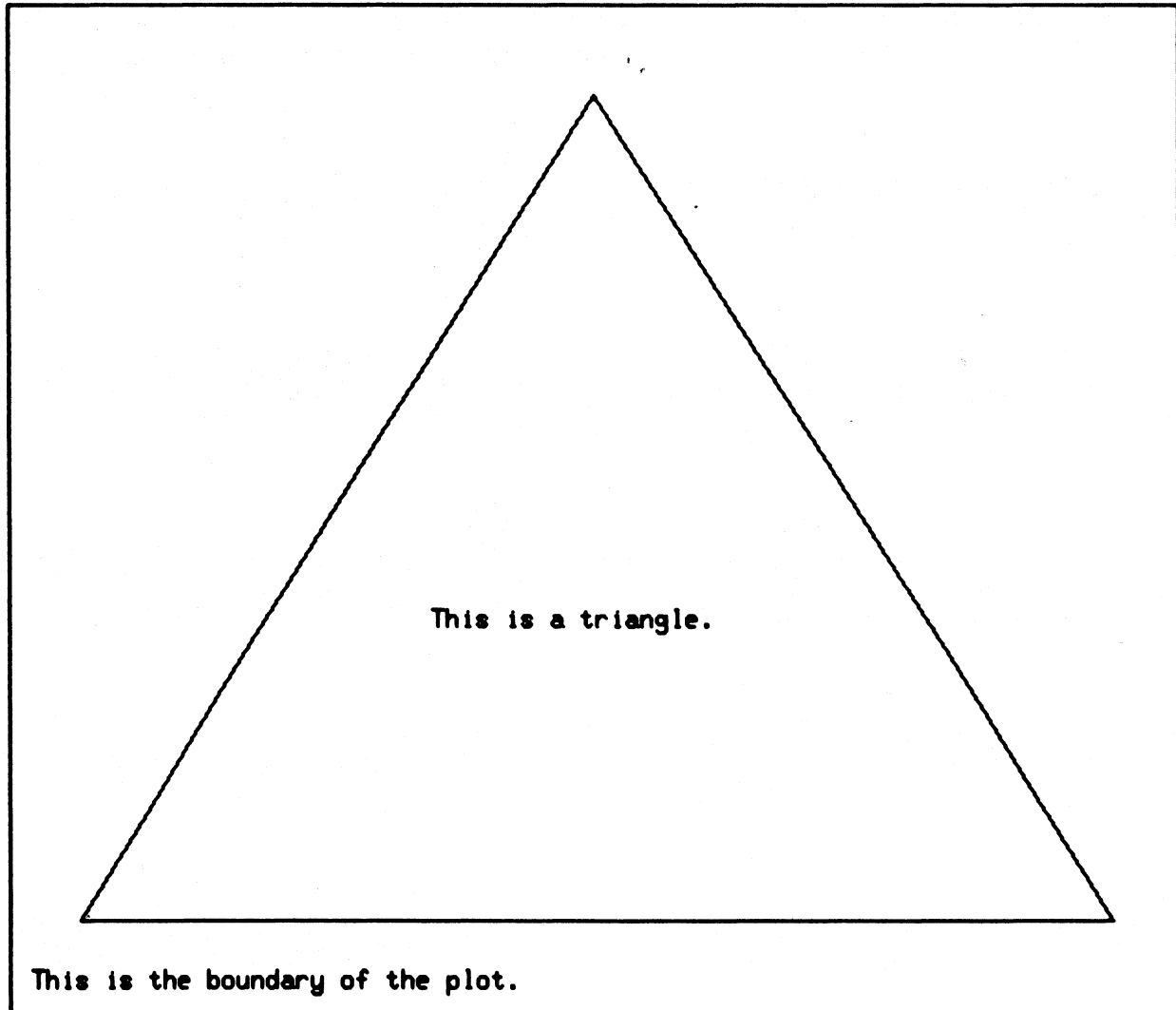

Figure 8-10. Example of a plot in the workspace.

### /P Switch

The preceding exercise introduced the /P switch. This switch tells the 4025 to translate a file being copied into plotter language. These examples show how to use the /P switch:

`!COPY TA1.6/P PL1 <CR>`

Copies a 4025-language command file from Tape Unit 1, file 6, to the Plotter, translating the file into plotter language.

`!COPY TA1.6/P TA2.1 <CR>`

Copies the command file at Tape Unit 1, file 6, to Tape Unit 2, file 1. While copying, translates the file from 4025 language to plotter language.

## PERIPHERAL DEVICES

**!COPY HO/P PL1 <CR>**

Copies text coming from the host computer to Plotter 1, translating 4025-language commands to plotter commands. Copy continues until any of the following occurs:

- The host sends an end-of-file string.
- The host sends a prompt string with the 4025 in buffered mode.
- The operator presses BREAK twice in quick succession.

*This command should be issued only by the host computer; it should not be typed on the 4025's keyboard.*

**!COPY HO/P TA2.1 <CR>**

Copies a command file from the host computer to Tape Unit 2, file 1. While copying, translates 4025-language commands to plotter language. As in the example above, copy continues until the 4025 receives an end-of-file or prompt string, or until the operator presses "BREAK, BREAK." *This command should be issued by the host computer, not typed on the 4025's keyboard.*

### NOTE

*The /P switch is always attached to the <source> not the <destination>, in a COPY command. Also, the only "source" to which /P may be attached are tape files and the host computer. That is,*

***!COPY HO/P PL1 <CR> and !COPY TA1.6/P PL1 <CR>***

*are permitted, but*

***!COPY WO/P PL1 <CR>***

*is not allowed.*

The COPY command with the /P switch translates only VECTOR, RVECTOR, and STRING commands into plotter language.

- VECTOR and RVECTOR commands are translated into plotter “move” and “draw” commands. (For a description of the RVECTOR command see the 4024/4025 Programmer’s Reference Manual.)
- STRING commands (used to insert text into a graphic region) are translated into plotter “print” commands. (The STRING command is described in the 4024/4025 Programmer’s Reference Manual.)
- All other 4025 commands in the file being translated *are ignored*. For instance, there are no plotter commands corresponding to the WORKSPACE and GRAPHICS commands used to set up a graphics region in the workspace. A command file for the 4025 might well include these commands, but when the file is translated into plotter commands, the WORKSPACE and GRAPHICS commands are ignored.

Note that the 4025’s LINE command is not translated into plotter language. You may use LINE commands to specify dashed lines in a command file, and those dashed lines will be displayed when you COPY the command file to the workspace; but when you COPY the file to the plotter using the /P switch, the dashed lines are drawn as solid lines.

## The PASS Command

There are many plotter commands which do not have corresponding 4025-language commands: “Alpha Rotate” and “Alpha Size” are examples. (Appendix E lists these and other plotter language commands; for more complete descriptions of their functions, see the 4662 Interactive Digital Plotter User’s Manual.)

The 4025’s PASS command provides a way to pass to the Plotter such special plotter commands as “Alpha Rotate” or “Alpha Size” This enables you (or the host computer) to write a 4025-language command file for the Plotter which includes these commands. Such a command file, being in 4025 language, can more easily be sent to and from the host computer than could a plotter-language file (which may include control characters like ETX).

### NOTE

*A 4025-language command file which includes PASS commands is not suitable for drawing graphs in the 4025’s workspace; it is only suitable for controlling the Plotter.*

In the PASS command, you specify a string of ASCII characters. Later, when the PASS command is translated into plotter language, the characters in the string are passed to the Plotter. Table 8-4 illustrates the PASS command:

Table 8-4

<b>EXAMPLES OF THE PASS COMMAND</b>	
<b>PASS Commands</b>	<b>Translations into Plotter Language</b>
!PASS "abcd" <CR> or !PAS "abcd" <CR>	<a><b><c><d> – The string of text, "abcd".
!PASS 65,66,67,68 <CR>	<A><B><C><D> – "ABCD"
!PASS "R10.3",3	<R><1><0><. ><3><ETX> – An "alpharotate" command: "Set the Plotter to print characters which follow as slanting upward at an angle of 10.3 degrees with respect to the X-axis."
!PASS "PHELLO",3 <CR>	The characters <P> <H> <e> <l> <l> <o> <ETX> – a "print" command: "Print HELLO on the Plotter."

## COPYING DATA TO AND FROM THE HOST COMPUTER

The COPY command has special features, and special requirements, that apply when COPYING to and from the host computer:

- When COPYING *from* the host computer, the data being copied must end with an *end-of-file string*.
- When COPYING *to* the host computer, the 4025 inserts an end-of-file string at the end of the data.
- Whenever a COPY is to be from the host computer, the COPY command should be issued by that computer – not typed on the keyboard.
- In COPYING from the host computer to a peripheral device (printer, Tape Drive, or Plotter), the data being copied may also be displayed in the 4025. A special switch (/D) is provided for this.

Each of these is discussed separately.

## End-of-File String

The end-of-file string was discussed earlier under "Copying from the Host to the Printer." The following summary of that discussion applies to all COPY operations that copy from the host to the printer or to the 4924 Tape Drive.

- An end-of-file string is required at the end of the data being copied from the host computer.
- You can examine the 4025's current end-of-file string by means of the PERIPHERALS command.
- You can define a new end-of-file string with the EOF command.

When the COPY command has the host as destination, the 4025 automatically inserts an end-of-file string at the end of the data being copied:

**!COPY WO HO <CR>**

Copies the data in the workspace to the host computer, appending an end-of-file string at the end of the data. The entire contents of the workspace is sent, including any field attribute codes. Functions like a SEND ALL command except for appending the end-of-file string.

**!COPY WO/U HO <CR>**

With the 4025 in form fillout mode, copies unprotected data in the workspace to the host computer, appending an end-of-file string at the end of the data being sent. Functions like a SEND ALL command except for appending the end-of-file string.

**!COPY WO/N HO <CR>**

Copies the contents of the workspace to the host computer, suppressing any field attribute codes and sending rulings characters as asterisks. An end-of-file string is appended at the end of the data being copied.

**!COPY TA1.6 HO <CR>**

Sends the data in Tape Unit 1, file 6, to the host computer. Appends an end-of-file string at the end of the data being copied.

## Issuing a “Copy from Host Computer” Command

When COPYing data from the host computer, the copy continues until one of the following occurs:

- The 4025 receives its current end-of-file string in the data coming from the host.
- The 4025, in buffered mode, receives a prompt from the host computer.
- The operator presses BREAK twice in quick succession.

Because they disable the keyboard, “copy from host computer” commands should be issued by the host computer, not typed on the keyboard. To see what can go wrong if you type such a command on the keyboard, consider the following:

1. The operator types a “copy from host to workspace command,” as follows:

!COPY WO PR <CR>

As soon as he presses RETURN to terminate the command, the 4025 begins looking for data coming from the host computer. It continues looking until one of the following happens: (a) it receives an end-of-file string, (b) it receives a prompt string in buffered mode, or (c) the operator presses BREAK twice in quick succession.

2. At this point, the 4025 is ready to copy data coming from the computer, but the computer is not sending it any data. For the computer to send the data, it must be given a command to do so. Unfortunately, since the keyboard is disabled, you cannot type the command.

The point is: don't try to issue a “copy from host computer” command from the keyboard. Let the host computer issue the command instead. One way to do this is to include the COPY command at the start of the text being copied. (An example of this is given earlier under “Copying from the Host to the Printer.”)

## The /D Switch

In copying data from the host computer to one of the 4025's peripheral devices, you may have the 4025 display the data at the time that it is copied. To do this, use the /D switch in the COPY command, as follows:

**!COPY HO/D PR <CR>**

Takes text coming from the host computer and sends it to the printer. Displays the text on the 4025's screen.

**!COPY HO/D TA1.6 <CR>**

Takes text coming from the host computer and sends it to Tape Unit 1, file 6. Displays the text on the 4025's screen.

**!COPY HO/D/P PL1 <CR>**

Takes the command file coming from the host computer, translates it into plotter language, and sends it to the Plotter. Sends the same command file, untranslated, to its own display. The result is that the Plotter draws the graph specified by the command file, and the 4025 displays the same graph in its workspace.





# Appendix A

## EXAMPLES OF COMMANDS

The following examples of the 4025's commands all assume that the command character is the exclamation point. <CR> denotes the RETURN key. Commands are included which are not discussed in this manual; for information on those commands, see the Programmer's Reference Manual.

<b>ATTRIBUTE</b>	<b>!ATT 1 &lt;CR&gt;</b>	Sets up a new field at the current cursor location in the workspace, and causes characters in that field to be displayed with character font number 1 (the rulings characters).
	<b>!ATT 0 &lt;CR&gt;</b>	Selects character font 0 for the field which begins at the current cursor position in the workspace.
	<b>!ATT P &lt;CR&gt;</b>	Defines a "protected" field, starting at the current cursor position.
	<b>!ATT A &lt;CR&gt;</b>	Defines an "alphanumeric" unprotected field at the current cursor location.
	<b>!ATT N &lt;CR&gt;</b>	Defines a "numeric" unprotected field at the current cursor location.
	<b>!ATT M &lt;CR&gt;</b>	Marks the field at the current cursor location as a "modified" field.
	<b>!ATT S &lt;CR&gt;</b>	Displays the field at the current cursor location using the "standard" visual attribute.
	<b>!ATT E &lt;CR&gt;</b>	Attaches the "enhanced" visual attribute to the field at the current cursor position.
	<b>!ATT PE-I &lt;CR&gt;</b>	Establishes a protected field, with visual attributes that "blink" between "enhanced" and "inverted".

## APPENDIX A

	!ATT 2 NS-U <CR>	Establishes a field which is displayed using character font 2, which is "numeric", and which is displayed "blinking between standard and underlined".
<b>BACKTAB</b>	!BAC 5 <CR>	Equivalent to pressing the BACK-TAB key 5 times.
<b>BAUD</b>	!BAU 300,1200<CR>	Sets the transmitting baud rate to 300 baud, and the receiving rate to 1200 baud.
	!BAU 9600 <CR>	Sets both transmitting and receiving baud rates to 9600 baud.
<b>BELL</b>	!BEL <CR>	Sounds the 4025's bell.
<b>BUFFERED</b>	!BUF <CR> !BUF Y <CR>	Puts the 4025 in buffered mode.
	!BUF N <CR>	Removes the 4025 from buffered mode.
<b>CLEAR</b>	!CLE <CR>	Clears all current key definitions; all keyboard keys revert to their original meanings.
<b>COMMAND</b>	!COM # <CR>	Changes the command character to the "number sign" (#).
	!COM 19 <CR>	Changes the command character to the ASCII character whose decimal equivalent is 19: the "DC3", or "device control #3" character.

<b>COPY</b>	<b>!COPY W P &lt;CR&gt;</b>	Sends the contents of the workspace to a peripheral device, such as the 4642 Printer. (Requires Option 3.)
	<b>!COPY H P &lt;CR&gt;</b>	Sends text from the host computer to the 4642 Printer. (Requires Option 3.)
<b>DCHAR</b>	<b>!DCH 5 &lt;CR&gt;</b>	Equivalent to pressing the DELETE CHAR key 5 times.
<b>DELAY</b>	<b>!DEL 20 &lt;CR&gt;</b>	Sets (to at least 20 milliseconds) the length of time that the 4025 delays before responding to a prompt from the host computer.
<b>DFONT</b>	<b>!DFO 31 &lt;CR&gt;</b>	Deletes character Font 31, so that the memory used for holding those characters may be used instead as graphics memory. (Requires Option 23, 24, 25, or 26.)
<b>DISCONNECT</b>	<b>!DIS &lt;CR&gt;</b>	Disconnects the 4025 from the communications line. (Requires Option 1.)
<b>DLINE</b>	<b>!DLI 6 &lt;CR&gt;</b>	Equivalent to pressing the DELETE LINE key 6 times; deletes 6 lines of text.
<b>DOWN</b>	<b>!DOW 15 &lt;CR&gt;</b>	Moves the cursor down 15 lines; like pressing the "down" cursor movement key 15 times.

## APPENDIX A

<b>DUPLEX</b>	!DUP <CR>	Sets the 4025 to full duplex.
	!DUP F <CR>	(This command requires Option 1; without Option 1, the 4025 is always set for full duplex.)
	!DUP H N <CR>	Sets the 4025 for half duplex, without supervisor. In buffered mode, line turnaround is used in lieu of the prompt string. (Requires Option 1.)
	!DUP H N L <CR>	
	!DUP H N P <CR>	Sets the 4025 for half duplex, without supervisor. In buffered mode, the prompt string is required in addition to line turnaround. (Requires Option 1.)
	!DUP H S <CR>	Sets the 4025 for half duplex with supervisor. (Requires Option 1.)
<b>ECHO</b>	!DUP H S L <CR>	In buffered mode, line turnaround is used in lieu of the prompt string. (Requires Option 1.)
	!DUP H S P <CR>	Sets the 4025 for half duplex with supervisor. In buffered mode, the prompt string is required in addition to line turnaround. (Requires Option 1.)
	!ECH L <CR>	Sets the 4025 for "local echo".
<b>EOF</b>	!ECH R <CR>	Sets the 4025 for "remote echo".
	!EOF /abc/<CR>	Sets the end-of-file string to the ASCII characters <a>,<b>,<c>. This string is used in COPY commands to mark the end of a file being sent from the host computer for the 4025 to copy on a 4642 printer. (Requires Option 3.)

<b>EOL</b>	!EOL <CR>	Sets the end-of-line string to "carriage return".
	!EOL 13 10 <CR>	Sets the end-of-line string to the ASCII characters whose decimal equivalents are 13 and 10: <CR>, <LF> ("carriage return, line feed").
	!EOL /abcDEF/ 13 10 <CR>	Sets the end-of-line string to the ASCII characters <a>, <b>, <c>, <d>, <e>, <f>, <CR>, <LF>.
<b>ERASE</b>	!ERA W <CR>	Erases the workspace.
	!ERA M <CR>	Erases the monitor.
	!ERA G <CR>	Erases the contents of the graphics area. (Requires Option 23, 24, 25, or 26.)
	!ERA <CR>	When this command is typed on the keyboard, the 4025 erases that scroll (keyboard or monitor) into which text from the keyboard is directed.  When this command comes from the computer, the 4025 erases that scroll into which text from the computer is directed.
<b>FIELD</b>	!FIE @ <CR>	Sets (to " @ ") the character which is used to precede fields when they are transmitted to the host computer.
	!FIE 02 <CR>	Selects the ASCII character whose decimal equivalent is "2" as the character which precedes fields when they are transmitted to the host computer.

## APPENDIX A

	<code>!FIE 2 &lt;CR&gt;</code>	Selects the numeral 2 as the character to precede fields when they are transmitted to the host computer.
<b>FORM</b>	<code>!FORM &lt;CR&gt;</code>	Puts the 4025 in form fillout mode.
	<code>!FORM Y &lt;CR&gt;</code>	
	<code>!FORM N &lt;CR&gt;</code>	Removes the 4025 from form fillout mode.
<b>GRAPHIC</b>	<code>!GRA 5,9 &lt;CR&gt;</code>	Sets up a graphic area in the workspace, containing all 80 columns of lines 5 through 9. (Requires Option 23, 24, 25, or 26.)
	<code>!GRA 5,9,10,70 &lt;CR&gt;</code>	Sets up a graphic area in the workspace, starting at row 5 and ending at row 9, and containing columns 10 through 70 in those rows. (Requires Option 23, 24, 25, or 26.)
<b>GTEST</b>	<code>!GTE &lt;CR&gt;</code>	Tests each bit of graphic RAM (Random Access Memory). Indicates for each character font whether RAM is installed, and, if installed, whether that RAM is OK. If faulty RAM is found, displays an error code for use by service personnel. (Requires Option 23, 24, 25, or 26.)
<b>HCOPY</b>	<code>!HCO W &lt;CR&gt;</code>	Copies one 53-line page from the workspace onto a TEKTRONIX 4631 Hard Copy Unit, starting with the first line of the workspace which is in view on the screen. (Requires Option 40.)

	!HCO 3 M <CR>	Copies three pages from the monitor onto a 4631 Hard Copy Unit. Copy begins with the first line of the monitor which is visible on the screen, and continues for three 53-line pages. (Requires Option 40.)
	!HCO S <CR>	Copies the contents of the screen onto a 4631 Hard Copy Unit. (Requires Option 40.)
<b>HRULE</b>	!HRU 3,5,15,2<CR>	Starts at row 3, column 5 in the workspace, and draws a horizontal ruling through 15 character positions. The ruling is a double line. (Requires Option 32.)
	!HRU 3,5,15,1<CR> !HRU 3,5,15<CR>	Starts at row 3, column 5 in the workspace, and draws a horizontal ruling through 15 character positions. The ruling is a single line. (Requires Option 32.)
<b>ICHAR</b>	!ICH <CR>	Puts the 4025 into insert mode. (The 4025 leaves insert mode on receiving a cursor movement character or a command which moves the cursor.)
<b>ILINE</b>	!ILI 3 <CR>	Inserts 3 lines in the text, starting at the current cursor location; equivalent to pressing INSERT LINE 3 times.

## APPENDIX A

<b>JUMP</b>	!JUM <CR>	Moves the cursor to the start of the first line of the workspace.
	!JUM 15 <CR>	Moves the cursor to the start of the 15th line of the workspace.
	!JUM 15,26 <CR>	Moves the cursor to row 15, column 26 in the workspace.
<b>LEARN</b>	!LEA Q /abc/ <CR>	Programs the shifted version of the Q key (uppercase Q) to mean the string of characters, <a>,<b>,<c>.
	!LEA Q /abc/ 13 <CR>	Programs the uppercase Q key to mean the string of characters, <a>, <b>, <c>, <CR>. The <CR> ("carriage return") character is represented in the LEARN command by its ASCII decimal equivalent, the number 13.
	!LEA F1 /abc/<CR>	Programs Function Key 1 to mean the string, <a>, <b>, <c>.
	!LEA S1 /abc/<CR>	Programs the shifted version of Function Key 1 to mean the string <a>, <b>, <c>.
<b>LEFT</b>	!LEF 5 <CR>	Moves the cursor 5 character positions to the left.
<b>LINE</b>	!LIN <CR> !LIN 1 <CR>	Sets the line type for subsequent VECTOR commands to "line type 1" - a solid line.
	!LIN 5 <CR>	Sets the line type to "line type 5".



	<b>!LINE &lt;CR&gt;</b>	Sets the line type to "line type E". Subsequent VECTOR commands will draw "erase vectors", which erase anything in their paths.
	<b>!LINE P &lt;CR&gt;</b>	Sets the line type to "line type P". Subsequent VECTOR commands will plot points, rather than draw lines.
<b>MARGINS</b>	<b>!MARG &lt;CR&gt;</b>	Sets the left margin workspace to column 1, and the right margin to column 80.
	<b>!MARG 5 &lt;CR&gt;</b>	Sets the left margin to column 5, and leaves right margin unchanged.
	<b>!MARG 10,70 &lt;CR&gt;</b>	Sets the left margin to column 10, and the right margin to column 70.
<b>MONITOR</b>	<b>!MON 5 H K &lt;CR&gt;</b>	Creates a workspace. Reserves the bottom 5 lines of the screen for displaying the monitor, leaving the 29 lines above for displaying the workspace. Directs text from the host computer and the keyboard to the monitor.
	<b>!MON H &lt;CR&gt;</b>	Directs text from the host computer to the monitor.
	<b>!MON K &lt;CR&gt;</b>	Directs text from the keyboard to the monitor.
	<b>!MON &lt;CR&gt;</b>	If this command is typed on the keyboard, it directs text from the keyboard to the monitor. If this command comes from the host computer, it directs text from the host computer to the monitor.

## APPENDIX A

<b>PARITY</b>	!PAR E <CR>	Sets the 4025 to even parity.
	!PAR O <CR>	Sets the 4025 to odd parity.
	!PAR N <CR>	Sets parity to "none"; the 4025 ignores the parity bit on input, and sets it to "0" on output.
	!PAR D <CR>	Sets parity to "data"; the parity bit is available for use as a data bit.
<b>PROMPT</b>	!PRO /abc/ <CR>	Sets the prompt string to <a>,<b>,<c>. In buffered mode, the 4025 must receive this string from the host before it sends each line of text from its transmit buffer.
	!PRO 13 10 <CR>	Sets the prompt string to the ASCII characters whose decimal equivalents are 13 and 10: <CR>,<LF>.
	!PRO <CR>	Sets the prompt string to the single character, <LF> ("line feed").
<b>REPORT</b>	!REP 5 <CR>	Causes the 4025 to send a report to the host computer, describing the status of device number 5.
<b>RDOWN</b>	!RDO 5 <CR>	Rolls the workspace or monitor scroll down 5 lines. (Equivalent to pressing the "down" scrolling key 5 times.) The action stops when the top of the scroll is in view on the screen.
<b>RIGHT</b>	!RIG 5 <CR>	Moves the cursor 5 character positions to the right.

<b>RUP</b>	!RUP 5 <CR>	Rolls the workspace or monitor scroll up 5 lines. (Equivalent to pressing the "up" scrolling key 5 times.) The action stops when the last line of text already entered in the scroll comes into view on the screen.
<b>RVECTOR</b>	!RVE 5,5,10,10 <CR>	"Relative vector" command. Same as a VECTOR command, except the coordinates are centered on the last beam position (end of the last line segment in a VEC or RVEC command), rather than being centered on the point (0,0).
<b>SEND ALL</b>	!SEN A <CR> !SEN <CR>	<p>If not in form fillout mode, sends to the computer all the data in the workspace, including attribute codes, which are encoded as ATTRIBUTE commands.</p> <p>If in form fillout mode, sends to the computer the contents of all the "blanks" of the form (the unprotected fields).</p>
<b>SEND MOD</b>	!SEN M <CR>	<p>If not in form fillout mode, functions like SEND ALL; sends the entire contents of the workspace to the computer.</p> <p>If in form fillout mode, sends to the computer the contents of those blanks ("unprotected fields") which have been modified since the last SEND MOD command. Also sends the contents of those protected fields which have been marked with the "modified" logical attribute.</p>

**APPENDIX A**

<b>SEND</b>	!SEN <CR>	Same as SEND ALL.
<b>SHRINK</b>	!SHR <CR> !SHR Y <CR>	Causes the 4025 to "shrink" x- and y-coordinates in subsequent VECTOR commands, by a factor of 5/8. This accomodates the 4025 to the range of possible coordinates in 4010-style graphic commands.
	!SHR H <CR>	Causes the 4025 to "shrink" y-coordinates (but not x-coordinates) in VECTOR commands, by 7/8. This pre-distorts graphs drawn on the 4025's screen, so that they appear in the proper proportion when copied on a 4631 Hard Copy Unit.
	!SHR B <CR>	Causes the 4025 to perform both "ordinary" and "hard copy" shrink operations on coordinates in subsequent VECTOR commands. Multiplies x-coordinates by 5/8, and y-coordinates by 35/64.
	!SHR N <CR>	Removes the 4025 from "shrink mode", so that x- and y-coordinates in subsequent VECTOR commands are not altered.
<b>SNOOPY</b>	!SNO <CR> !SNO Y <CR>	Puts the 4025 in "snoopy mode". (In snoopy mode, the "non-printing" ASCII characters are represented on the display by two-letter abbreviations.)
	!SNO N <CR>	Removes the 4025 from snoopy mode.
<b>STOPS</b>	!STO 5,10,15 <CR>	Puts tab stops in columns 5, 10, and 15.

<b>STRING</b>	!STR /abc/ <CR>	Inserts the characters "abc" in the graphics area. (Requires Option 23, 24, 25, or 26.)
<b>SYMBOL</b>	!SYM 2,30,0,255,0,255,0,255,0,255,0,255,0,255,0,255 <CR>	Defines symbol number 2 of character Font 30 as follows: The top line has all its dots turned off (displayed dark), the next line has all its 8 dots turned on (displayed light), and succeeding lines have all dots off, or all dots on, alternately. The number describing each line of dots in the SYMBOL command is the decimal equivalent of the binary number whose individual bits represent the dots of that line. (Requires Option 23, 24, 25, or 26.)
<b>SYSTAT</b>	!SYS <CR>	Displays the system status message in the monitor.
<b>TAB</b>	!TAB 2 <CR>	<p>Performs the same action as pressing the TAB key twice.</p> <p>If not in form fillout mode, each tab advances the cursor one tab stop or to the beginning of the next line.</p> <p>If in form fillout mode, each tab advances the cursor to the next blank (unprotected field) of the form.</p>

<b>TEST</b>	!TES <CR>	<p>Checks the 4025's memory, testing each character location and displaying the four checksums for the system ROM (Read Only Memory). In addition to the checksums, displays a sample of each character that may be displayed from fonts 0 and 1, and rings the bell.</p> <p>In checking the memory, any text in the workspace or monitor is destroyed.</p>
<b>UP</b>	!UP 5 <CR>	<p>Moves the cursor up 5 lines; similar to pressing the "up" cursor movement key 5 times.</p>
<b>VECTOR</b>	!VEC 0,0,100,100,0,10<CR>	<p>Draws a line in the graphic area of the workspace, starting at point (0,0) and continuing to (100,100); draws another line from there to the point (0,10). (Requires Option 23, 24, 25, or 26.)</p>
<b>VRULE</b>	!VRU 3,5,15,2<CR>	<p>Starts at workspace row 3, column 5, and draws a vertical ruling downward through 15 character positions. The ruling is a double line. (Requires Option 32.)</p>
	!VRU 3,5,15,1<CR>	<p>Starts at workspace row 3, column 5, and draws a vertical ruling down through 15 character positions. The ruling is a single line. (Requires Option 32.)</p>

**WORKSPACE**

!WOR 20 H K <CR>

Creates a workspace, and allots the top 20 lines of the screen for displaying it. Directs text from the host computer and the keyboard to that workspace.

!WOR H <CR>

Directs text from the host computer to the workspace.

!WOR K <CR>

Directs text from the keyboard to the workspace.

Table B-1

BITS				0	0	0	1	1	1	1	1	1		
B7	B6	B5	B4	B3	B2	B1	CONTROL		FIGURES		UPPERCASE		LOWERCASE	
0	0	0	0	0	0	0	NUL	DLE	SP	0	@	P	\	p
0	0	0	1	0	0	0	SOH	DC1	!	1	A	Q	a	q
0	0	1	0	0	0	0	STX	DC2	"	2	B	R	b	r
0	0	1	1	0	0	0	ETX	DC3	#	3	C	S	c	s
0	1	0	0	0	0	0	EOT	DC4	\$	4	D	T	d	t
0	1	0	1	0	0	0	ENQ	NAK	%	5	E	U	e	u
0	1	1	0	0	0	0	ACK	SYN	&	6	F	V	f	v
0	1	1	1	0	0	0	BEL BELL	ETB	/	7	G	W	g	w
1	0	0	0	0	0	0	BS BACK SPACE	CAN	(	8	H	X	h	x
1	0	0	1	0	0	0	HT	EM	)	9	I	Y	i	y
1	0	1	0	0	0	0	LF	SUB	*	:	J	Z	j	z
1	0	1	1	0	0	0	VT	ESC	+	;	K	[	k	{
1	1	0	0	0	0	0	FF	FS	,	<	L	\	l	;
1	1	0	1	0	0	0	CR RETURN	GS	-	=	M	]	m	}
1	1	1	0	0	0	0	SO	RS	.	>	N	^	n	~
1	1	1	1	0	0	0	SI	US	/	?	O	_	o	RUBOUT (DEL)



# Appendix B

## THE ASCII CODE

When the 4025 stores text in its memory, or sends and receives text from the computer, it represents that text as a collection of telegraph characters, using the ASCII telegraph code. ("ASCII" stands for "American Standard Code for Information Interchange". This code is known internationally as the "ISO-7" code.)

*Bits.* Each character of the ASCII code is a collection of seven "bits" ("binary digits"). (Often an eighth bit, the "parity bit" is added for error-detection purposes.) Each bit is either "1" or "0". With 7 bits, there are 128 possible combinations; these are the 128 ASCII characters.

*ASCII Decimal Equivalents.* Each character may be regarded as a binary numeral, representing a number in the range from 0 to 127. For instance, the ASCII character for "Z" is "1011010", which is the binary numeral for the number 90. We say that 90 is the "ASCII decimal equivalent" for the letter Z.

*Printing and Non-Printing Characters.* The 128 characters in the ASCII alphabet include many characters which can be printed on paper: upper and lower case letters of the alphabet, numerals, the "space" character, punctuation marks and special symbols. In addition, there are some "non-printing" characters, or "control characters". These have special meanings such as "carriage return" or "device control #1", and are used to control machines.

*Using the ASCII Code Chart.* Table B-1 is an "ASCII Code Chart"; it lists the 128 ASCII characters, and shows the binary bits and ASCII decimal equivalent for each character. The chart is a rectangular array of 8 columns, each containing 16 characters; this makes it more compact than a table with a single column of 128 characters.

### NOTE

*If you have Option 4A or 4C, refer to Appendix C for revised ASCII Code Chart.*

The "high order bits" (B7,B6,B5) for the characters in each column are the same; they appear at the top of the column. Similarly, the "low order bits" (B4,B3,B2,B1) for the characters in each row are the same, and are shown at the left of the row.

For instance, the letter "Z" is in the sixth column and twelfth row. At the top of the column, we see its high order bits: "101"; its low order bits, "1010", appear at the left of the row. Hence, its seven binary bits are:

B7	B6	B5	B4	B3	B2	B1
1	0	1	1	0	1	0

## APPENDIX B

The binary numeral "1011010" represents the number "90." This is the ASCII decimal equivalent for "Z", and appears next to it in the chart.

The "control characters" occupy the first two columns in Table B-1. There are keys on the keyboard for only a few of these characters: "escape" ("ESC"), "tab" ("HT"), "backspace" ("BS"), "carriage return" ("CR"), and "line feed" ("LF"). However, you can send any control character to the computer by using the CTRL key.

To send one of the control characters, you hold down the CTRL key and type one of the other ASCII characters. For instance, to type an "ENQ" character, you press CTRL-E; to type a "DC3", you press CTRL-S. Table B-2 lists the control characters, the keys you press to type these characters, and the two-letter mnemonics by which they are displayed when using the LEARN key.

Table B-2

CONTROL CHARACTERS

Mnemonic	Usual ASCII Abbrev.	Name of Character	Keys to Press
N	NUL	Null	CTRL- @
S	SOH	Start of Heading	CTRL-A
X	STX	Start of Text	CTRL-B
E	ETX	End of Text	CTRL-C
T	EOT	End of Transmission	CTRL-D
Q	ENQ	Enquiry	CTRL-E
A	ACK	Acknowledgement	CTRL-F
B	BEL	Bell	CTRL-G
S	BS	Backspace	CTRL-H
H	HT	Horizontal Tab	CTRL-I
L	LF	Line Feed	CTRL-J
V	VT	Vertical Tab	CTRL-K
F	FF	Form Feed	CTRL-L
R	CR	Carriage Return	CTRL-M
O	SO	Shift Out	CTRL-N
S	SI	Shift In	CTRL-O
L	DLE	Data Link Escape	CTRL-P
D <sub>1</sub>	DC1	Device Control 1	CTRL-Q
D <sub>2</sub>	DC2	Device Control 2	CTRL-R
D <sub>3</sub>	DC3	Device Control 3	CTRL-S
D <sub>4</sub>	DC4	Device Control 4	CTRL-T
N	NAK	Negative Acknowledgement	CTRL-U
S	SYN	Synchronization Character	CTRL-V
E	ETB	End of Transmission Block	CTRL-W
C	CAN	Cancel	CTRL-X
E	EM	End of Medium	CTRL-Y
S	SUB	Substitute	CTRL-Z
E	ESC	Escape	CTRL-[
F	FS	Field Separator	CTRL-\
G	GS	Group Separator	CTRL-]
R	RS	Record Separator	CTRL-↑
			CTRL- ^ (CTRL-up arrow or CTRL-circumflex accent)
U	US	Unit Separator	CTRL- _ (CTRL-underscore)



# Appendix C

## OPTIONS

The following options are available for the 4025.

### **Option 1: Half Duplex**

Permits half duplex data communications, in addition to the full duplex data communications provided as standard equipment.

(Requires Option 35.)

### **Option 2: Current Loop**

Permits the 4025 to communicate with its host computer or another device by means of a 20 mA current loop rather than the standard RS-232 interface.

### **Option 3: RS-232 Peripheral Interface**

Permits the 4025 to transmit to RS-232 compatible peripheral devices such as the TEKTRONIX 4642 Printer. With this option, data from the host computer or the 4025's workspace can be printed on the 4642 Printer.

(Requires Options 35 and 36.)

### **Option 4: GPIB Peripheral Interface**

Permits the 4025 to communicate with and control the TEKTRONIX 4924 Digital Cartridge Tape Drive and 4662 Interactive Digital Plotter. (These devices communicate with the 4025 over the General Purpose Interface Bus (GPIB), which is defined in IEEE Standard 488-1975).

Allows the 4025 to save data or command files on the 4924, and retrieve them later without the need for intervention by the host computer. Typical applications include storage and retrieval of forms, command lists, etc.

(Requires Options 35 and 36.)

**APPENDIX C**

**Option 4A: United Kingdom Character Set**

This option permits Tektronix 4020 series terminals to change to a United Kingdom standard keyboard layout so that the United Kingdom characters are displayed. The only change is that the “#” sign is replaced by the English “£” sign. This is shown in the revised keyboard configuration (see Figure C-1), and the revised ASCII Code Chart (see Table C-1). When this key is pressed (or the appropriate code is received by the terminal), the “£” sign is displayed on the screen.

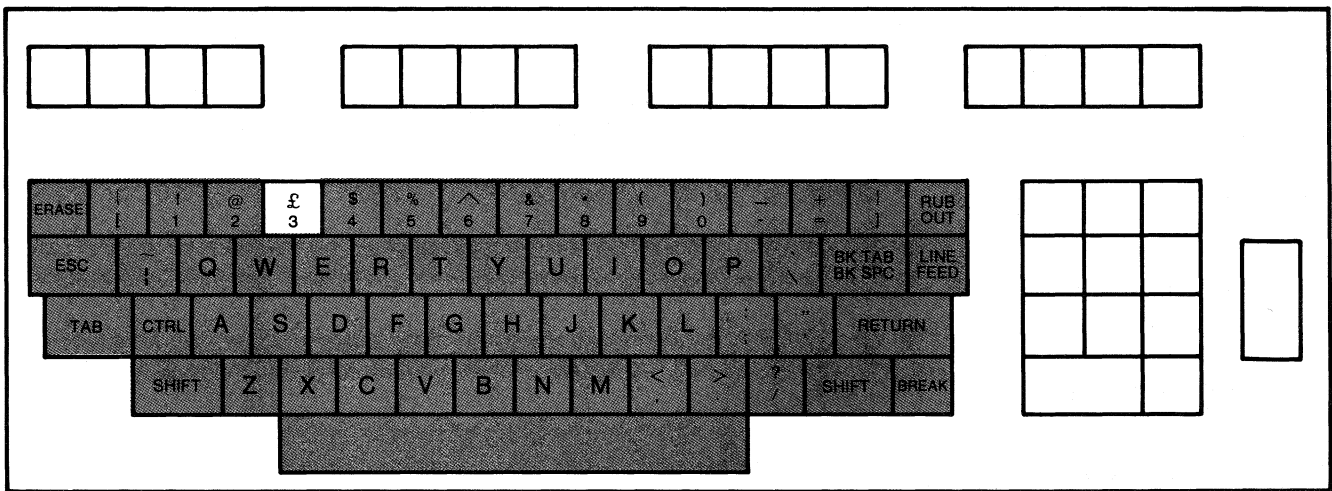

2943-1A

**Figure C-1. United Kingdom Keyboard.**

Table C-1

UNITED KINGDOM CHARACTER SET

BITS				0 0		0 0 1		0 1 0		0 1 1		1 0 0		1 0 1		1 1 0		1 1 1	
B7	B6	B5		CONTROL				HIGH X & Y GRAPHIC INPUT				LOW X				LOW Y			
B4	B3	B2	B1																
0	0	0	0	NUL 0	DLE 16	SP 32	0 48	@ 64	P 80	\ 96	p 112								
0	0	0	1	SOH 1	DC1 17	! 33	1 49	A 65	Q 81	a 97	q 113								
0	0	1	0	STX 2	DC2 18	" 34	2 50	B 66	R 82	b 98	r 114								
0	0	1	1	ETX 3	DC3 19	£ 35	3 51	C 67	S 83	c 99	s 115								
0	1	0	0	EOT 4	DC4 20	\$ 36	4 52	D 68	T 84	d 100	t 116								
0	1	0	1	ENQ 5	NAK 21	% 37	5 53	E 69	U 85	e 101	u 117								
0	1	1	0	ACK 6	SYN 22	& 38	6 54	F 70	V 86	f 102	v 118								
0	1	1	1	BEL 7	ETB 23	/ 39	7 55	G 71	W 87	g 103	w 119								
1	0	0	0	BS 8	CAN 24	( 40	8 56	H 72	X 88	h 104	x 120								
1	0	0	1	HT 9	EM 25	) 41	9 57	I 73	Y 89	i 105	y 121								
1	0	1	0	LF 10	SUB 26	* 42	: 58	J 74	Z 90	j 106	z 122								
1	0	1	1	VT 11	ESC 27	+ 43	; 59	K 75	[ 91	k 107	{ 123								
1	1	0	0	FF 12	FS 28	, 44	< 60	L 76	\ 92	l 108	l 124								
1	1	0	1	CR 13	GS 29	- 45	= 61	M 77	] 93	m 109	} 125								
1	1	1	0	SO 14	RS 30	. 46	> 62	N 78	^ 94	n 110	~ 126								
1	1	1	1	SI 15	US 31	/ 47	? 63	O 79	- 95	o 111	RUBOUT (DEL) 127								

2943-2

**APPENDIX C**

**Option 4B: French Character Set**

This option permits Tektronix 4020 terminals to change to the French "AZERTY" keyboard layout for the standard ASCII character set. All the characters are the same as on the 4020 standard keyboard. The only changes are that four keys are switched around. This is shown in the revised keyboard configuration (see Figure C-2). There are no changes to the ASCII Code Chart. When these four keys are pressed (or the appropriate codes are received by the terminal), these characters are displayed on the screen.

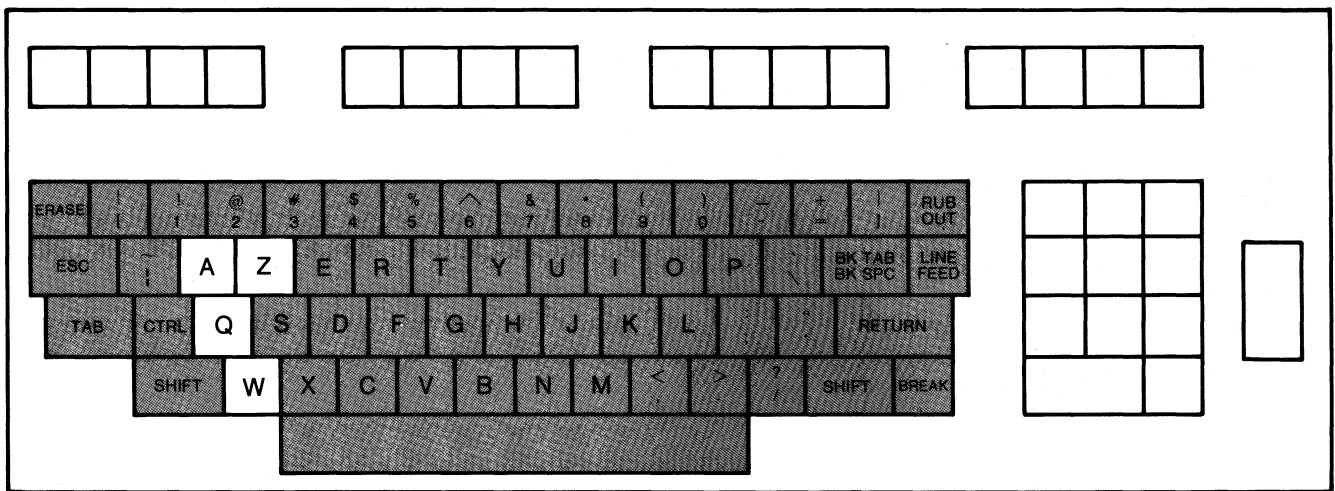

2944-1A

**Figure C-2. French Keyboard.**



**Option 4C: Swedish Character Set**

This option permits Tektronix 4020 terminals to change to a Swedish standard layout so that the Swedish characters are displayed. There are 17 changes to the keyboard, with three of these changes being new characters. These changes are shown in the revised keyboard configuration (see Figure C-3), and the revised ASCII Code Chart (see Table C-2). When these 17 keys are pressed (or the appropriate codes are received by the terminal), the corresponding characters are displayed on the screen.

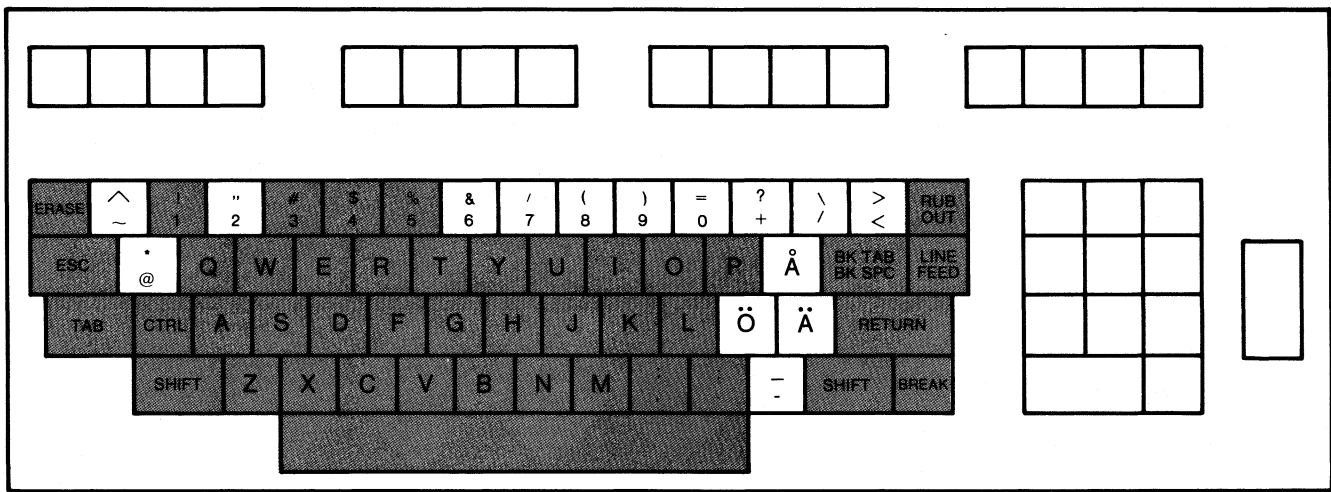

2847-1A

Figure C-3. Swedish Keyboard.

Table C-2

SWEDISH CHARACTER SET

BITS				CONTROL		HIGH X & Y GRAPHIC INPUT		LOW X		LOW Y				
B7	B6	B5	B4	B3	B2	B1	0 0 0	0 0 1	0 1 0	0 1 1	1 0 0	1 0 1	1 1 0	1 1 1
0	0	0	0	0	0	0	NUL 0	DLE 16	SP 32	0 48	@ 64	P 80	\ 96	p 112
0	0	0	0	1	0	0	SOH 1	DC1 17	! 33	1 49	A 65	Q 81	a 97	q 113
0	0	1	0	0	0	0	STX 2	DC2 18	" 34	2 50	B 66	R 82	b 98	r 114
0	0	1	1	0	0	0	ETX 3	DC3 19	# 35	3 51	C 67	S 83	c 99	s 115
0	1	0	0	0	0	0	EOT 4	DC4 20	\$ 36	4 52	D 68	T 84	d 100	t 116
0	1	0	1	0	0	0	ENQ 5	NAK 21	% 37	5 53	E 69	U 85	e 101	u 117
0	1	1	0	0	0	0	ACK 6	SYN 22	& 38	6 54	F 70	V 86	f 102	v 118
0	1	1	1	0	0	0	BEL 7	ETB 23	/ 39	7 55	G 71	W 87	g 103	w 119
1	0	0	0	0	0	0	BS 8	CAN 24	( 40	8 56	H 72	X 88	h 104	x 120
1	0	0	1	0	0	0	HT 9	EM 25	) 41	9 57	I 73	Y 89	i 105	y 121
1	0	1	0	0	0	0	LF 10	SUB 26	* 42	: 58	J 74	Z 90	j 106	z 122
1	0	1	1	0	0	0	VT 11	ESC 27	+ 43	; 59	K 75	Ä 91	k 107	ä 123
1	1	0	0	0	0	0	FF 12	FS 28	, 44	< 60	L 76	Ö 92	l 108	ö 124
1	1	0	1	0	0	0	CR 13	GS 29	- 45	= 61	M 77	Å 93	m 109	å 125
1	1	1	0	0	0	0	SO 14	RS 30	. 46	> 62	N 78	^ 94	n 110	~ 126
1	1	1	1	0	0	0	SI 15	US 31	/ 47	? 63	O 79	_ 95	o 111	RUBOUT (DEL) 127

2947-2

**Option 10: Polling Interface**

Permits the 4025 to function in a polling environment, as one of several display stations communicating with the host computer through a polling controller. (See Option 11.)

(Includes Option 2.)

**Option 11: Polling Controller**

The Tektronix polling system permits multiple terminals to be connected to a single host communications port. The Polling Controller (4025 Option 11) provides for control of up to seven additional display stations via a 20 mA current loop interface.

The Option 11 Polling Controller communicates with the host computer through an RS-232 port, using IBM 3271/3277 Bisynchronous EBCDIC protocol.

In addition to the RS-232 port for communicating with the host and the current loop port for communicating with the display stations, the Option 11 Polling Controller includes a third communication port. This is an RS-232 transmit-only port for driving a printer.

**Options 20, 21, and 22: Added Display Memory**

The standard 4025 includes 4096 bytes of display memory. (Each byte is 8 binary bits, and can hold one ASCII character.) Options 20, 21, and 22 expand this, permitting larger quantities of text to be stored in the 4025's workspace and monitor.

Option 20: A total of 8192 (8K) bytes of display memory.

Option 21: A total of 16,384 (16K) bytes of display memory.

Option 22: A total of 32,768 (32K) bytes of display memory.

**Options 23, 24, 25, and 26: Graphics Memory**

Permits the 4025 to draw graphs in its workspace. Solid lines and seven types of dashed lines can be drawn, and individual points can be plotted. Individual lines can be erased by drawing over them with "erase vectors".

In addition, the "graphics" options permit the user to create alternate character fonts for displaying text in the workspace. This is done by telling the 4025 how to draw each character of each new font.

## APPENDIX C

These options differ only in the amount of “graphics memory” they include. Larger amounts of graphics memory permit the 4025 to draw larger and more complex graphs in its workspace, and to create more alternate character sets.

Option 23: 4096 (4K) bytes of graphics memory.

Option 24: 8,192 (8K) bytes of graphics memory.

Option 25: 16,384 (16K) bytes of graphics memory.

Option 26: 32,768 (32K) bytes of graphics memory.

### **Option 31: Character expansion.**

Permits the addition of ROMs (Read Only Memories) containing alternate character fonts.

### **Option 32: Ruling Characters**

Adds the “ruling” character font, permitting single and double lines to be drawn on forms in the workspace.

(Requires Option 31.)

### **Option 34: Math Characters**

Adds a set of “math” characters to permit mathematical symbols to be displayed in the workspace. Includes standard mathematical symbols, Greek letters, etc.

(Requires Option 31.)

### **Option 35: ROM Expansion**

Permits ROMs (Read Only Memories) to be added, enabling the 4025 to execute instructions associated with Options 3, 4, 23, 24, 25, 26, and 41.

**Option 36: Peripherals ROM**

Provides instructions for the 4025's processor, allowing it to communicate with RS-232 or GPIB peripheral devices.

(Required for Option 3 or Option 4.)

**Option 40: Hard Copy and Video Out**

Permits the 4025 to copy the contents of its workspace or monitor, or the screen, on a TEKTRONIX 4631 Hard Copy Unit. The copies are each about 8 1/2 by 11 inches in size, and can show 53 lines of the workspace or monitor contents. One or several 53-line pages may be copied, and the copies can show rulings, special characters, and graphics as well as ordinary text.

Also permits the 4025's display to be viewed on a standard video monitor, or copied on a TEKTRONIX 4632 Video Hard Copy Unit.

**Option 41: Self Test**

Enables the 4025 to perform certain internal diagnostic tests.

(Requires Option 35.)

**Option 48: 220 Volt Power**

Enables the 4025 to operate from 220 volt 50 or 60 Hz power lines.



# Appendix D

## SPECIFICATIONS

Table D-1

### DISPLAY MECHANISM

Display type	Video monitor.
Screen size	30.0 cm (12.0 in) diagonal.
Usable display area	17.0 cm x 23.0 cm (6.7 in x 9.0 in)
Phosphor type	P-39 green phosphor
Video bandwidth	20 MHz
Raster lines	Standard 525 line scan, with 480 lines displayed.
Scan	30 Hz interlaced scan.
Refresh rate	
Dot	30 times/second
Frame	30 times/second
Field	60 times/second

Table D-2

**DISPLAY CHARACTERISTICS**

Cursor type	Wide underscore
Character size	7 x 9, in an 8 x 14 dot matrix. (Graphics cells are 8 x 14 matrix.)
Character sets Standard	64/96 upper and lower case ASCII. (A special "snoopy mode" is provided which displays all characters and commands. Snoopy mode enables the display of 128 characters.)
Optional	64 characters each, to a maximum of 6 character sets; or 128 characters each, to a maximum of 3 sets. Can include rulings or math characters, for example.  With the graphics option, up to 16 character sets can be defined by the user.
Characters/line	80
Lines/display	34
Total characters/display	2720
Visual attributes	Characters can be displayed with shaded background, inverted fields (dark on light background rather than light on dark background), or underlines. In addition, the display can "blink" (alternate) between combinations of visual attributes.
Logical attributes	Fields can be protected, modified, alphanumeric, or numeric.



Table D-3

## INTERFACE CHARACTERISTICS

Transmission speed	The transmitting and receiving baud rates may be independently selected up to 9600 baud. Baud rates can be entered from the keyboard or the host computer.
Interface with host computer	
Standard	RS-232 full duplex, asynchronous serial.
Optional   Option 1	RS-232 half duplex, with or without supervisory channel. External clock, XI.
Option 2	20 mA current loop.
Option 11	Polling controller (IBM 3270 compatibility) Converts IBM 3270 protocol to 4020-series polling protocol.
Optional interfaces with peripheral devices	
Option 3	RS-232, transmit only, for printer.
Option 4	IEEE 488-1975 GPIB (General Purpose Interface Bus), for TEKTRONIX 4924 Digital Cartridge Tape Drive or 4662 Interactive Digital Plotter.
Option 10	Polling Interface - permits multiple terminal configurations on one host communications line. Terminals are under control of one 4025 with the Polling Controller (Option 11). Host computer interface is RS-232, terminal interface is current loop.
Option 40	Hard Copy connector for TEKTRONIX 4631 Hard Copy Unit, and standard 75-ohm video output for external video monitor.

**Table D-3 (cont.)**

Video Signals	Generates 525 line interlaced 60 Hz composite video. Does not accept external synchronizing pulses.
Peripheral Devices	4642 Printer 4631 Hard Copy Unit 4924 Digital Cartridge Tape Drive 4662 Interactive Digital Plotter

**Table D-4**

**BUFFERING AND EDITING CAPABILITIES**

Size of display memory	4K bytes standard; may be expanded to 8K, 16K, or 32K (Options 20, 21, and 22.)
Parts of memory	<p data-bbox="263 1371 363 1402">Monitor</p> <p data-bbox="263 1520 412 1551">Workspace</p>

**Table D-5**  
**KEYBOARD SPECIFICATIONS**

Number of keys	86
Lighted keys	4 (Insert Mode, TTY Lock, Numeric Lock, Command Lockout)
Programmable keys	80
Major keyboard functions	Typewriter keys, terminal function control, programmable function keys, numeric pad, cursor control, scrolling.
Tactile features	Curved profile, tactile feedback at typing "home" position.
Relationship to display	Detachable (flexible 8 foot cable)
Editing keys	Delete Character Delete Line Erase and Skip Insert Line Insert Mode

Table D-6

**GRAPHICS SPECIFICATIONS**

(For 4025s with Option 23, 24, 25, or 26.)

The maximum amount of graphics memory that may be needed depends on the number of graphics 'cells' (character positions) in the part of the workspace used for holding the graph. Display memory is also required to put graphics in the workspace.

More complex graphs require more memory. Seldom, however, is a graphic display so complex and so dense that it uses the maximum amount of graphics memory.

<p>Amount of Graphics Memory</p> <p>Option 23</p> <p>Option 24</p> <p>Option 25</p> <p>Option 26</p>	<p>4096 8-bit bytes (covers 256 cells).</p> <p>8192 bytes (covers 512 cells).</p> <p>16384 bytes (covers 1024 cells).</p> <p>32768 bytes (covers 2048 cells).</p>
<p>Line types</p>	<p>Solid lines.</p> <p>Seven styles of dashed lines.</p> <p>Single points.</p> <p>"Erase vectors", which erase previously drawn lines.</p>
<p>Type of display</p>	<p>Dot matrix: each graphics cell (character position) has 14 rows of 8 dots each.</p>
<p>Resolution</p>	<p>28 addressable points/cm (71/inch).</p>

**Table D-6 (cont.)**

User-definable character sets	That part of graphics memory not used for displaying graphic information may be used for defining alternate character fonts with which to display text. Up to 16 fonts may be defined by the operator or the host computer.
Characters per font	128
Number of fonts available	
Option 23	2
Option 24	4
Option 25	8
Option 26	16

**Table D-7**

**PHYSICAL CHARACTERISTICS**

Weight	27.2 kg (60 lb)
Dimensions	
Cabinet	
Height	31.7 cm (12.5 in)
Width	44.5 cm (17.5 in)
Depth	54.0 cm (21.25 in)
Keyboard	
Height	7.6 cm (3.0 in)
Width	45.7 cm (18.0 in)
Depth	23.5 cm (9.25 in)

**Table D-8**  
**POWER REQUIREMENTS**

Line plug and power cord	15 ampere capability, detached.		
Input Line voltages	VOLTAGE	RANGE	FUSE
Standard	115 Vac	90-100 V (low) 105-126 V (med) 112-136 V (high)	3 A
Option 48	220 Vac	180-220 V (low) 208-252 V (med) 224-272 V (high)	1.5 A
Line frequency	49 to 61 Hz		
Power consumption	295 W maximum at 125 Vac		

# Appendix E

## PLOTTER COMMANDS

This appendix gives examples of plotter commands, both in "plotter language" and in "4025 language." In these examples, ASCII control characters are included in angle brackets — that is, <ETX> denotes the "end-of-text" character, <CR> denotes "carriage return," etc.

Table E-1

### PLOTTER LANGUAGE COMMANDS

Command	Effect
H<CR> or H<ETX>	<b>Home.</b> Moves the pen to the upper left corner of the plotting area.
M 50,75 <CR> or M50,75 <ETX>	<b>Move.</b> Moves the pen to the point (50,75) in the Plotter's system of coordinates.
<b>NOTE</b>	
<i>The Plotter's coordinate system is not the same as the 4025's. The Plotter's x-axis always runs from 0 to 150, and its y-axis runs from 0 to 100.</i>	
D 100,50 <CR> or D100,50 <ETX>	<b>Draw.</b> Draws a line from the current pen position to the point (100,50) in the Plotter's system of coordinates.
D 100,50 0,0 50,10 <CR> or D100,50,0,0,50,10 <ETX>	Draws a line from the current pen position to the point (100,50); from there, to the point (0,0); and from there, to (50,10).
PThis is a test.<ETX>	<b>Print.</b> Prints on the Plotter, starting at the current pen position, the message, "This is a test."

## APPENDIX E

Command	Effect
S 1.5,3.0 <CR> or S1.5,3.0 <ETX>	<b>Alpha Scale.</b> Sets the size of each character cell to 1.5 graphic display units in the x-direction and 3.0 graphic display units in the y-direction. (The "graphic display unit" is a measure of length used by the Plotter. In the x-direction, it is 1/150 of the length of the plotting area; in the y-direction, it is 1/100 of the height of the plotting area.)
R 10 <CR> or R10<ETX>	<b>Alpha Rotate.</b> Sets the angle at which alphanumeric characters are printed on the plotting surface. Characters printed after this command is executed slant upwards at ten degrees with respect to the positive x-axis.
F 2 <CR> or F2<ETX>	<b>Alpha Font.</b> Selects printing font number 2 from among the Plotter's seven fonts.
A <CR> or A <ETX>	<b>Alpha Reset.</b> Resets the alphanumeric printing parameters (Alpha Scale, Alpha Rotate, Alpha Font) to their default values.
T 0 <CR> or T0 <ETX>	<b>Prompt Light.</b> Turns off the PROMPT light on the Plotter's front panel.
T 1 <CR> or T1 <ETX>	Turns on the Plotter's PROMPT light.



Table E-2

## TRANSLATION OF PLOTTER COMMANDS INTO 4025 LANGUAGE

Command Name	Plotter Language	4025 Language
HOME	H <CR>	!PASS "H",13
	H <ETX>	!PASS "H",3
MOVE	M 50,75 <CR>	!PASS "M 50,75",13
	M50,75 <ETX>	!PASS "M50,75",3
DRAW	D100,50 <ETX>	!PASS "D100,50",3
	D100,50,0,0 <ETX>	!PASS "D100,50,0,0",3
MOVE, followed by DRAW	M50,75 <ETX> D100,100 <ETX>	!VEC 213,30,427.479

## NOTE

*The coordinates in the 4025-language VECTOR command differ from those in the plotter-language MOVE and DRAW commands. This is because the 4025's system of coordinates differs from that of the Plotter. In translating VECTOR commands, the 4025 assumes that a graphics area with a maximum x-coordinate of 639 and maximum y-coordinate of 500 is to be mapped onto a Plotter work area with maximum x-coordinate of 127.80 and maximum y-coordinate of 100.*

PRINT	PThis is a test.<ETX>	!STRING "This is a test."
ALPHA SCALE	S1.5,3.0 <ETX>	!PASS "S1.5,3.0",3
ALPHA ROTATE	R10 <ETX>	!PASS "R10",3
ALPHA FONT	F2 <ETX>	!PASS "F2",3
ALPHA RESET	A <ETX>	!PASS "A",3
PROMPT LIGHT	T0 <ETX>	!PASS "T0",3
	T1 <ETX>	!PASS "T1",3



# Appendix F

## TESTING THE 4025

The 4025 has four commands (TEST, GTEST, STEST, and CALIBRATE) for performing diagnostic tests on itself. This appendix describes how to use these commands to verify that the 4025 is functioning properly. (The commands may also be used by service personnel to help isolate malfunctions; however, that is beyond the scope of this manual.)

Of the four “test” commands, only one (TEST) is available in all 4025s. The GTEST command is available with the graphics memory option (Option 23, 24, 25, or 26), and the STEST and CALIBRATE commands are available with the Self Test option (Option 41).

- The TEST command checks the 4025’s memory to be sure that it is present and functioning, displays checksums, and displays samples of the characters in the standard and rulings character fonts. Samples of different visual attributes are also displayed.
- The GTEST (Graphics Memory Test) command tests each cell of graphics memory. It displays a list of the possible character fonts, showing which fonts have graphics memory installed. If a particular character font has graphics memory installed, the 4025 checks that memory and displays an error code if it finds a defect. (The error code tells service personnel which part is defective.)
- The STEST (Self Test) command causes the 4025 to run a sequence of tests to verify that its different parts (keyboard, display memory, program memory, etc.) are all functioning correctly.
- The CALIBRATE command puts a test pattern on the screen, for use by service personnel in adjusting the display.

Each of these commands is discussed separately.

### NOTE

*These commands destroy the contents of both scrolls of memory. Do not type them if you want to save the text in the workspace.*

## TEST COMMAND

The TEST command displays checksums for the 4025's Read-Only memory and shows samples of the characters in the standard and rulings character fonts. To see the effect of this command, type it as follows:

```
!TEST <CR> or !TES <CR>
```

There is a delay while the 4025 computes checksums for its memory. After the delay, the terminal displays the checksums, samples of all characters in the standard character font (and the rulings font if Option 32 is installed), and samples of the visual enhancements. During the test, the lights in the lighted function keys turn on and then off. At the end of the test, the 4025 rings its bell. Figure F-1 illustrates the display.

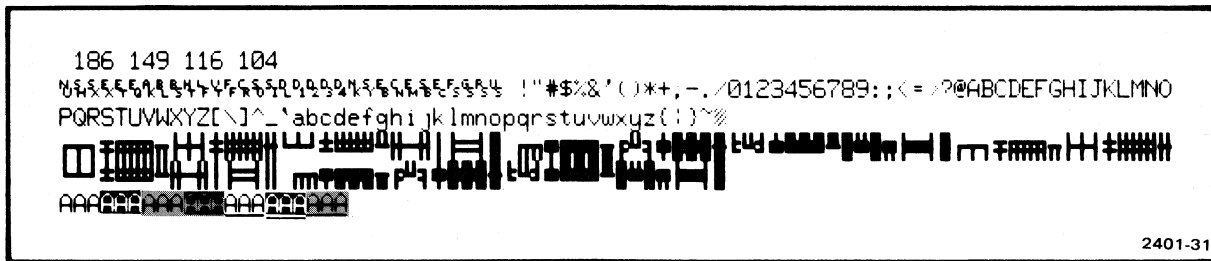

Figure F-1. TEST display.

## GTEST COMMAND (OPTIONS 23, 24, 25, AND 26)

If Option 23, 24, 25, or 26 (Graphics Memory) is installed, the GTEST (Graphics Memory Test) command provides a way to test that memory. To use this command, type it as follows:

```
!GTEST <CR> or !GTE <CR>
```

There is a delay while the 4025 checks its graphics memory, bit by bit. You should get a display like that in Figure F-2. The following character fonts should be present:

Option 23 (4K graphics memory):	Fonts 30 and 31
Option 24 (8K):	Fonts 28 to 31
Option 25 (16K):	Fonts 24 to 31
Option 26 (32K):	Fonts 16 to 31

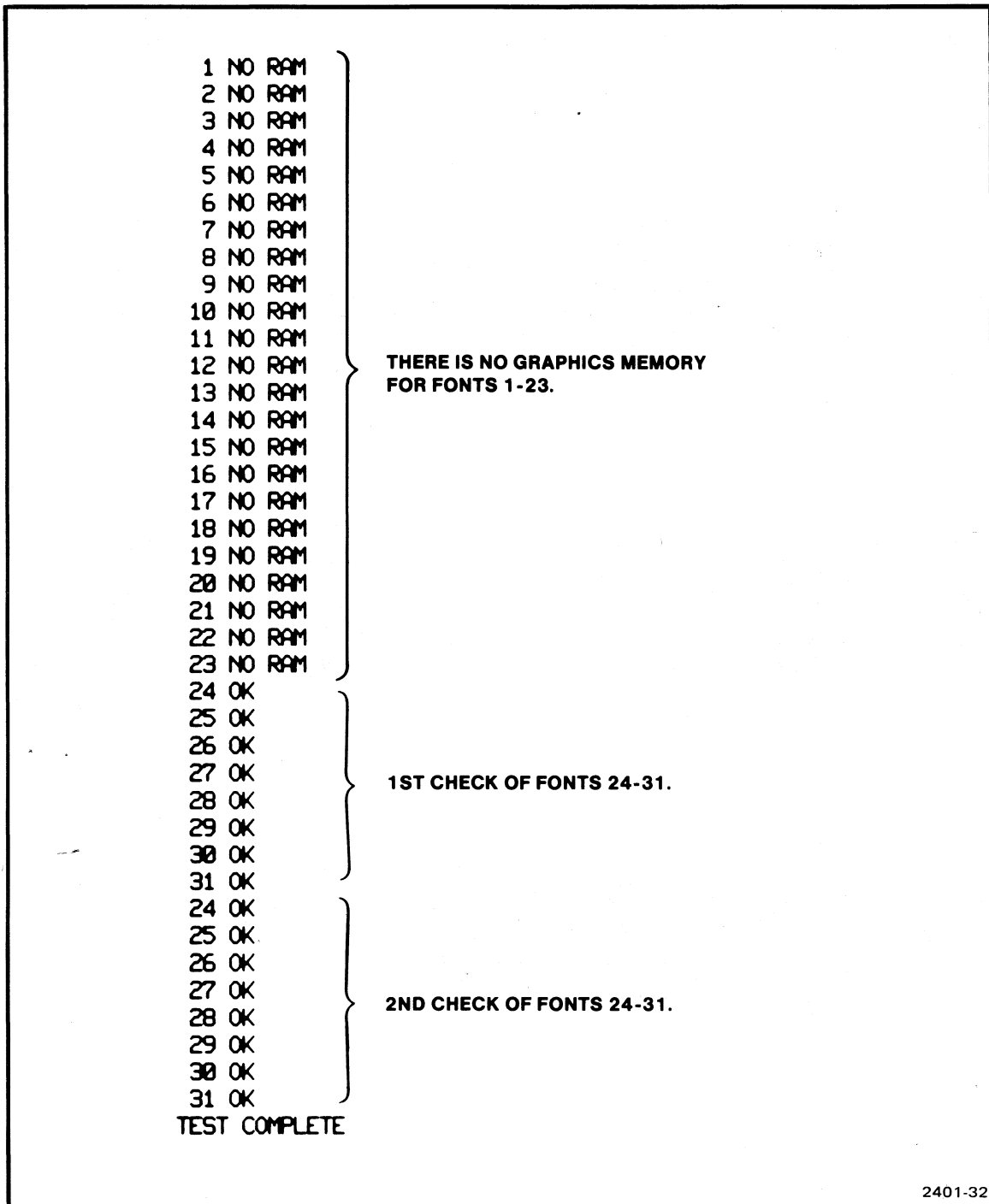

Figure F-2. Result of GTEST command.

## STEST COMMAND (OPTION 41)

The STEST (System Test) command provides a way for you or the service technician to make detailed tests of all parts of the 4025. To perform these tests, follow this procedure:

1. Disconnect the 4025 from the computer, and connect the special Self Test Adapter to the 4025's RS-232 cable, as shown in Figure F-3.

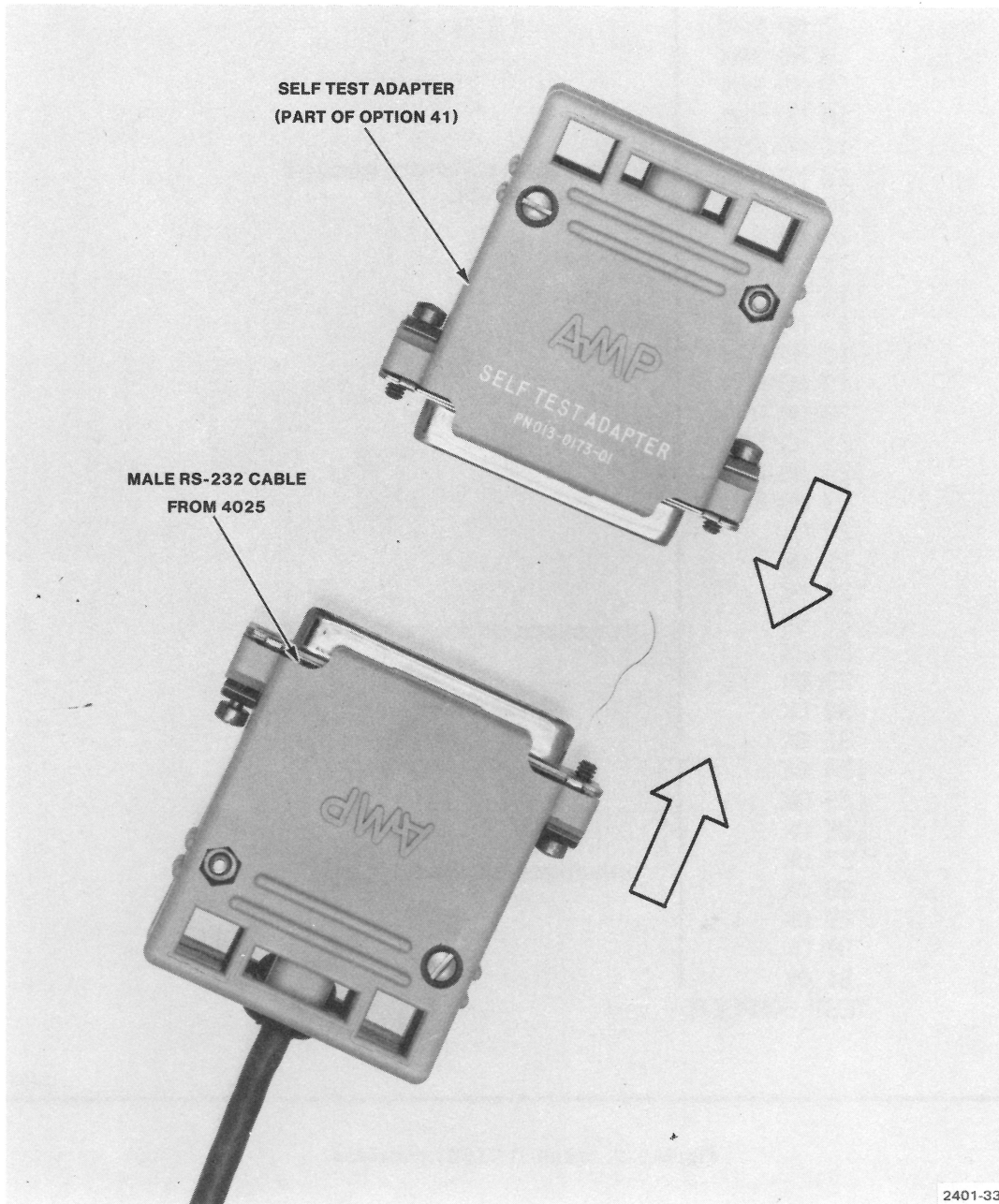

Figure F-3. Connecting the Self Test Adapter.

2. Type the STEST (Self Test) command:

!STEST <CR> or !STE <CR>

3. To show that the first part of the test is being carried out, the 4025 uses its lighted function keys to display the binary numeral for the number one: 0001 (Figure F-4).

If all is well, this numeral is displayed only briefly, and is then replaced by the binary numeral two: 0010. (The COMMAND LOCKOUT light turns off, and the NUMERIC LOCK light turns on.)

If the 4025 should fail this part of the test, it will display the message "System RAM error." Should this happen, press MASTER RESET to exit the test, and call your nearest Tektronix service center: there is a defect in the 4025's system RAM.

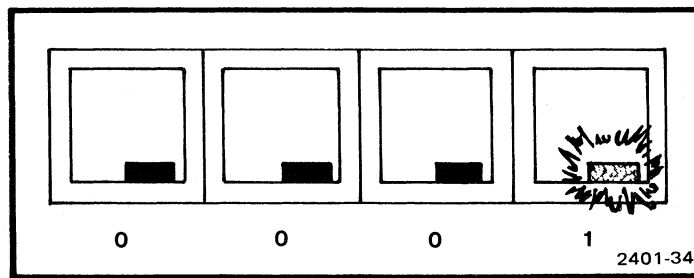

Figure F-4. Function key lights during first part of test.

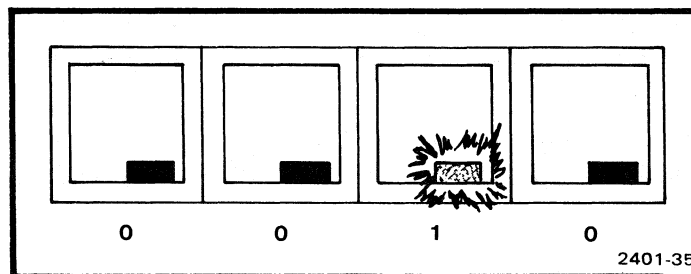

Figure F-5. Function key lights during second part of test.

## APPENDIX F

4. To test the keyboard, press each of its keys in turn. You must press them in the order shown in Figure F-6, as follows:
  - a. Space bar (the lowest key in the group of ASCII keys).
  - b. The next lowest row of keys in the ASCII keys, proceeding from left to right: left SHIFT key (LSH), Z, X, C, V, B, N, M, <, >, ?, right SHIFT key (RSH), BREAK key (BRK).
  - c. The next row above, from left to right: TAB, CTRL, A, S, D, F, G, H, J, K, L, :, ";", RETURN.
  - d. The next row above, from left to right: ESC, ~, Q, W, E, R, T, Y, U, I, O, P, ', BK TAB (displayed as BTB), LINE FEED.
  - e. The row just above, from left to right: ERASE, {, |, @, #, \$, %, †, &, \*, (, ), -, +, }, RUB OUT.
  - f. The cursor/numeric pad keys and the pad terminator key, in the following order: 0, ., /, 1, 2, 3, 4, 5, 6, 7, 8, 9, PT.
  - g. All sixteen function keys, from left to right: F1, F2, . . . , F16.

As you press each key, the 4025 displays an abbreviation for the key *it expects you to press* (not necessarily the key you actually press, if you don't press the keys in order). This abbreviation is either the "shifted" character for that key, or a short mnemonic (such as "LSH" for the left SHIFT key).

If you press the correct key, and its keyswitch functions correctly, then when you press the *next* key, the new abbreviation will over-write the old. However, if a key malfunctions, its abbreviation is not over-written. At the end of the test, abbreviations for any defective keys will remain on the display, together with a "Test failed" message. If all keys are pressed in the right order, and they all function correctly, a "Test complete" message appears.



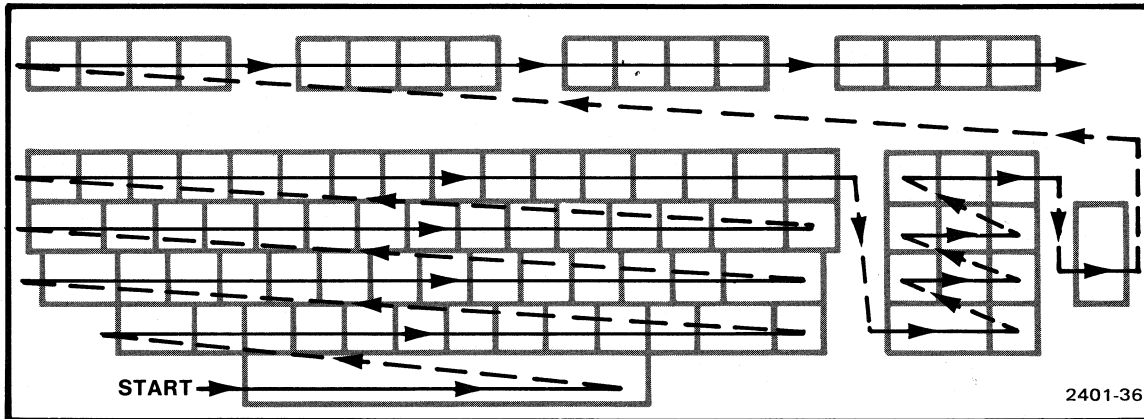

Figure F-6. Order to press keys during keyboard test.

5. After the "Test complete" (or "Test failed") message, press any key on the keyboard; this advances the 4025 to part three of the test. The lighted function keys display the binary numeral for the number three (0011), as shown in Figure F-7, and the screen displays the message "Cmos RAM test."

During this test, the 4025 saves the content of its CMOS battery-powered RAM (Random-Access Memory), and then tests every word of that RAM. If the RAM functions properly, the test ends with the message "Test Complete." If the 4025 finds a defect, it displays an error message for use by service personnel.

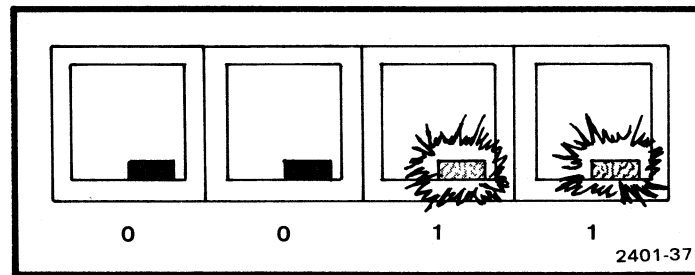

Figure F-7. Function key lights during third part of test.

APPENDIX F

6. After the "Test complete" (or error message), press any key on the keyboard; this advances the 4025 to part four of the test. The lighted function keys will display the binary numeral for the number four (0100), as shown in Figure F-8. The message "ROM checksums" appears, followed by some numbers. These numbers are "checksums" by which service personnel can verify that the correct instructions are installed in the 4025's internal program memory.

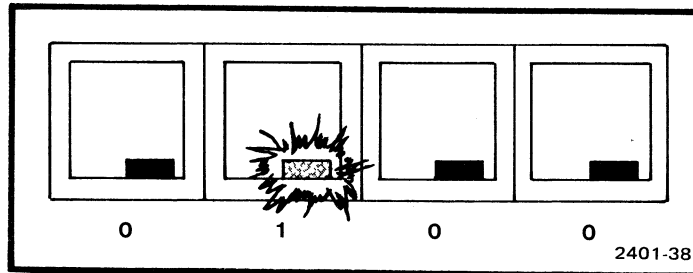

Figure F-8. Function key lights during fourth part of test.

7. Press any key on the keyboard; this advances the 4025 to part five of the test. The lighted function keys will display the binary numeral (0101) for the number five, as shown in Figure F-9. Strange patterns appear on the screen as the 4025 checks its display memory. When the test is complete, the screen should erase and display a message like that in Figure F-10. The middle line tells the amount of display memory installed in the 4025.

If numbers or an "Interrupt error" message should appear, the 4025 has detected a fault in its display memory or in its vertical retrace interrupt timer; call your Tektronix service center.

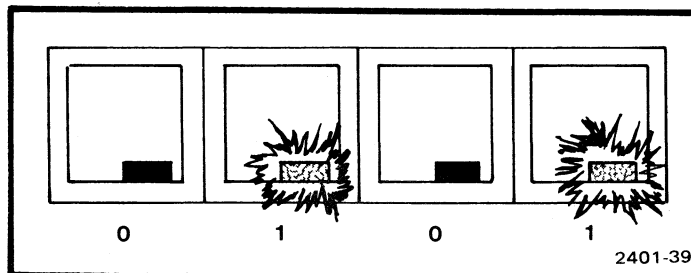

Figure F-9. Function key lights during fifth part of test.

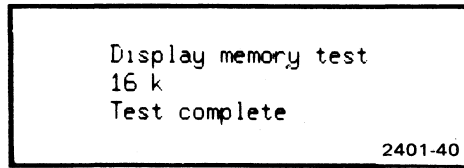

Figure F-10. Display after part five of test.

8. Check to be sure that the special Self Test Adapter is installed as shown in Figure F-3. Then press any key on the keyboard to advance to part six of the test. The 4025 displays the binary numeral (0110) for the number six in its function key lights (Figure F-11), and "Communications test" appears on the screen.

As the 4025 advances through the test, several messages replace each other in quick succession below the words "Communications test." The test should end with "Test complete" displayed, as in Figure F-12.

Should the test end with "Baud rate error," "Data error," "Line status error," or "Interrupt error" displayed, then the 4025 has found a fault in its Communications Interface Board; call your Tektronix service center.

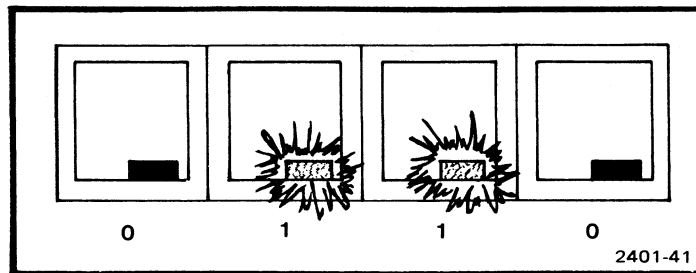

Figure F-11. Function key lights during sixth part of test.

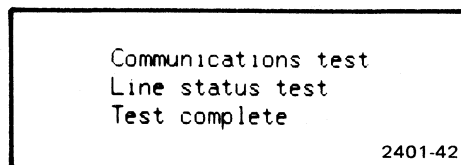

Figure F-12. Display after part six of test.

9. Press any keyboard key; after a short delay the screen should erase and the cursor appear. This concludes the self test.

**NOTE**

*If you want to skip the keyboard test, you may type the STEST command as follows:*

*!STEST NOKBD <CR> or !STE N <CR>*

*If your 4025 has Option 1 (Half Duplex) installed, you should include the letter H as a parameter in the STEST command, as follows:*

*!STEST H <CR> or !STE H <CR>*

*You can include both N and H in the command if you have Option 1 installed and want to skip the keyboard test:*

*!STEST N H <CR>*

## **CALIBRATE COMMAND (OPTION 41)**

The CALIBRATE command displays a test pattern for use by service personnel in adjusting the 4025's video display unit. To see this pattern (Figure F-13), type the command as follows:

*!CALIBRATE <CR> or !CAL <CR>*

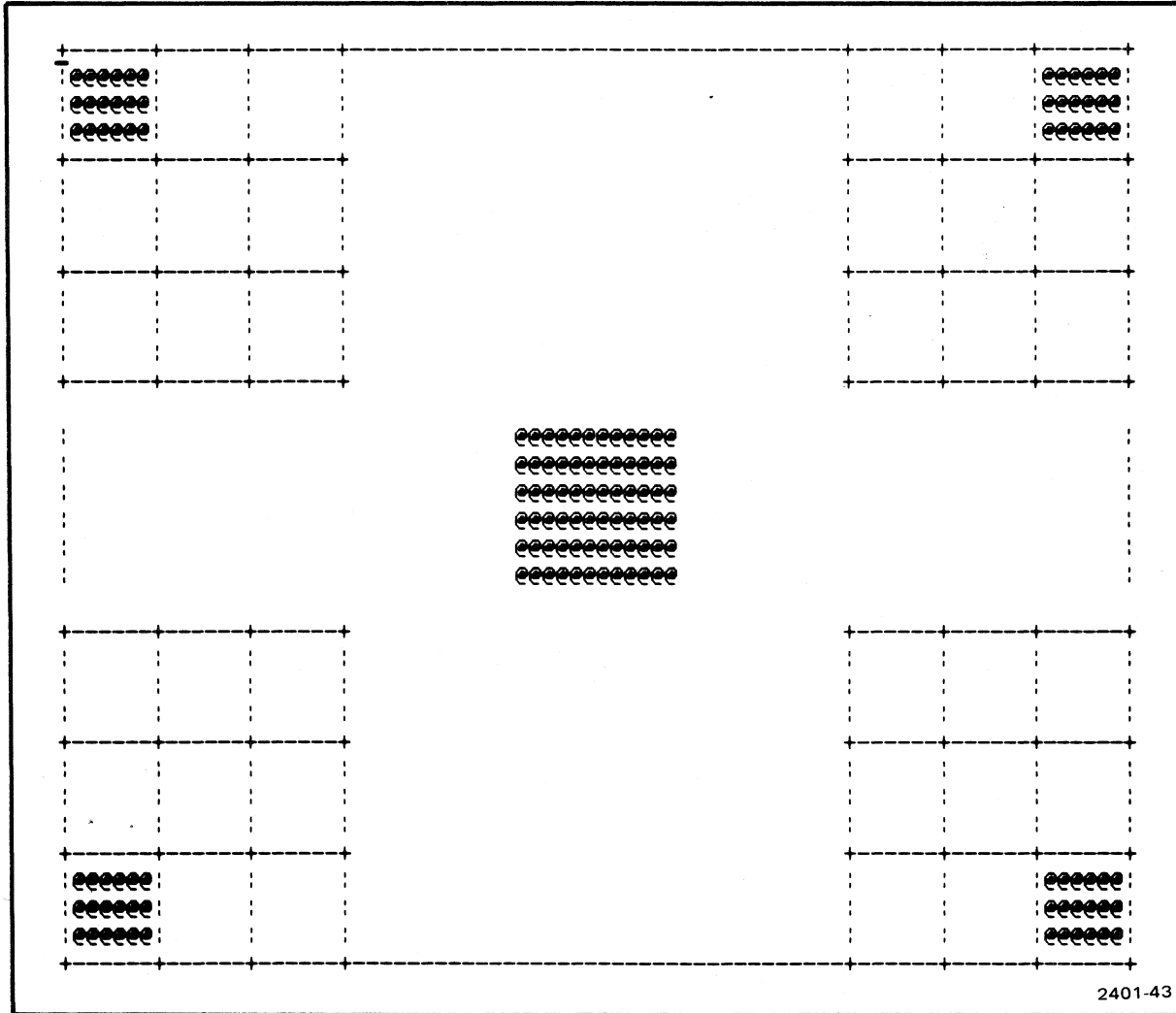

Figure F-13. CALIBRATE display.



## OPERATOR'S REFERENCE TABLE

Please record the following settings for future reference:

Transmitting Baud Rate	TB=
Receiving Baud Rate	RB=
Command Character	CC=
Prompt String	PR=
End-of-line String	EL=
Duplex (Full or Half)	DU=
Echo (Remote or Local)	EC=
Parity (None, Even, Odd, or Date)	PA=

