

VT 220

Pocket Service Guide

digital

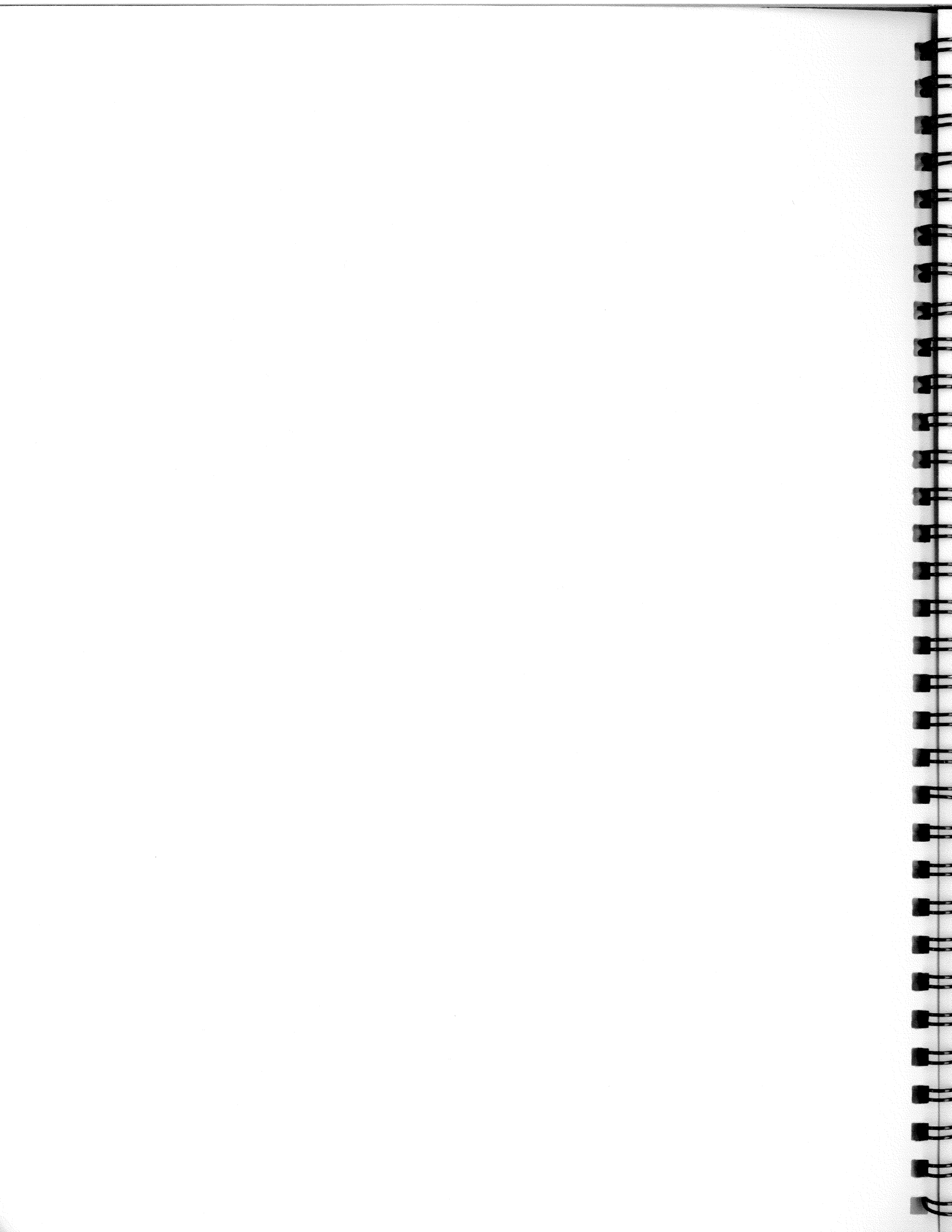

EK-VT220-PS-001

VT 220

Pocket Service Guide

Digital Equipment Corporation

1st Edition, August 1983

Copyright © 1983
by Digital Equipment Corporation
All Rights Reserved

The reproduction of this material, in part or whole, is strictly prohibited. For copy information, contact the Educational Services Department, Digital Equipment Corporation, Maynard, Massachusetts 01754.

The information in this document is subject to change without notice. Digital Equipment Corporation assumes no responsibility for any errors that may appear in this document.

Printed in U.S.A.

The following are trademarks of Digital Equipment Corporation, Maynard, Massachusetts.

| | | |
|---|--------------|----------------|
|  | DECwriter | RSTS |
| DEC | DIBOL | RSX |
| DECsystem-10 | MASSBUS | UNIBUS |
| DECSYSTEM-20 | PDP | VAX |
| DECUS | P/OS | VMS |
| DECmate | Professional | VT |
| DECnet | Rainbow | Work Processor |

CONTENTS

INTRODUCTION

| | |
|----------------------|------|
| Purpose | vii |
| Product | vii |
| Tools Required | viii |

1 TESTING AND TROUBLESHOOTING THE VT220 VIDEO TERMINAL

| | | |
|------|---|----|
| 1.1 | General | 1 |
| 1.2 | Testing and Troubleshooting | 1 |
| 1.3 | Power-Up Self-Test | 3 |
| 1.4 | EIA Port Data Lines Loopback Self-Test | 6 |
| 1.5 | Printer Port External Loopback Self-Test | 8 |
| 1.6 | EIA Port Control Lines Loopback Self-Test | 8 |
| 1.7 | 20 mA Port Loopback Self-Test | 9 |
| 1.8 | Screen Alignment Self-Test | 10 |
| 1.9 | Printer Problems | 11 |
| 1.10 | Self-Test Error Codes | 11 |
| 1.11 | Troubleshooting Miscellaneous Problems | 11 |

2 FRU REMOVAL AND REPLACEMENT

| | | |
|-----|----------------------------------|----|
| 2.1 | General | 15 |
| 2.2 | Access Cover | 15 |
| 2.3 | Terminal Controller Board | 18 |
| 2.4 | Power Supply/Monitor Board | 19 |
| 2.5 | Flyback Transformer | 23 |
| 2.6 | CRT Assembly | 27 |
| 2.7 | Keyboard | 28 |
| 2.8 | Recommended Spares List | 31 |

3 VIDEO MONITOR ALIGNMENT

| | | |
|---------|----------------------------|----|
| 3.1 | General | 33 |
| 3.2 | Monitor Adjustments | 33 |
| 3.2.1 | Initial Preparations | 33 |
| 3.2.2 | Character Quality | 35 |
| 3.2.2.1 | Brightness | 35 |
| 3.2.2.2 | Contrast | 35 |
| 3.2.2.3 | Vertical Linearity | 35 |
| 3.2.2.4 | Focus | 36 |

| | | |
|---------|--|----|
| 3.2.3 | Horizontal Hold (Display Instability Adjustment) | 36 |
| 3.2.4 | Display Centering Adjustments | 36 |
| 3.2.4.1 | Horizontal Centering | 36 |
| 3.2.4.2 | Vertical Centering | 37 |
| 3.2.5 | Display Size | 38 |
| 3.2.5.1 | Horizontal Width | 38 |
| 3.2.5.2 | Vertical Height | 38 |

4 SET-UP REFERENCE MATERIAL

| | |
|-------------------|------------------------------------|
| APPENDIX A | VT220 DOCUMENTATION |
| APPENDIX B | FRU EXPLODED VIEW DRAWINGS |
| APPENDIX C | CABLE INFORMATION |
| APPENDIX D | PHYSICAL FUNCTIONAL DIAGRAM |

FIGURES

| | | |
|------|--|----|
| 1-1 | Indication of Successful Self-Test | 3 |
| 1-2 | Rear Connector Panel of VT220 | 7 |
| 2-1 | Removing the Screws on the Access Cover | 16 |
| 2-2 | Removing the Access Cover | 17 |
| 2-3 | Removing the Terminal Controller Board | 18 |
| 2-4 | Disconnecting the Flat Cable and the "Power OK" Indicator 2-wire Cable | 19 |
| 2-5 | Disconnecting the 6-wire Input Cable and the 7-wire Cable to the Flyback Transformer | 20 |
| 2-6 | Removing the CRT Ground Wire and the Round CRT Connector | 21 |
| 2-7 | Removing the Screws from the Power Supply/Monitor Board | 21 |
| 2-8 | Freeing the CRT Round Connector Cable and Disconnecting the 4-wire Cable to the Yoke | 22 |
| 2-9 | Discharging the CRT Anode | 23 |
| 2-10 | Cutting the Tie Wrap that Secures the Anode Wire | 24 |
| 2-11 | Removing the CRT Anode Connector from the CRT | 25 |
| 2-12 | Disconnecting the 7-wire Connector from the Power Supply/Monitor Board | 26 |
| 2-13 | Removing the Flyback Transformer | 26 |
| 2-14 | Rear Panel of VT220 | 27 |
| 2-15 | Removing the Keyboard | 28 |
| 2-16 | Installing the Legend Strip and Keyboard Standoffs | 29 |
| 2-17 | Installing the Replacement Keyboard | 30 |
| 3-1 | Video Adjustment Locations | 34 |
| 3-2 | Brightness, Contrast, and Tilt Controls | 35 |
| 3-3 | Centering Adjustments | 37 |
| 3-4 | Horizontal Width Adjustment | 38 |
| B-1 | VT220 FRUs (Exploded View) | 43 |
| C-1 | Cable Summary | 45 |
| D-1 | Physical Functional Diagram | 48 |

TABLES

| | | |
|-----|-----------------------------------|----|
| 1-1 | Self-Test Chart | 2 |
| 1-2 | VT220 Error Messages | 4 |
| 1-3 | VT220 LED Error Reporting | 5 |
| 1-4 | VT220 Troubleshooting Chart | 12 |
| 2-1 | Recommended Spares List | 31 |
| C-1 | Interface Cables | 46 |
| C-2 | Modem Control Selections | 46 |

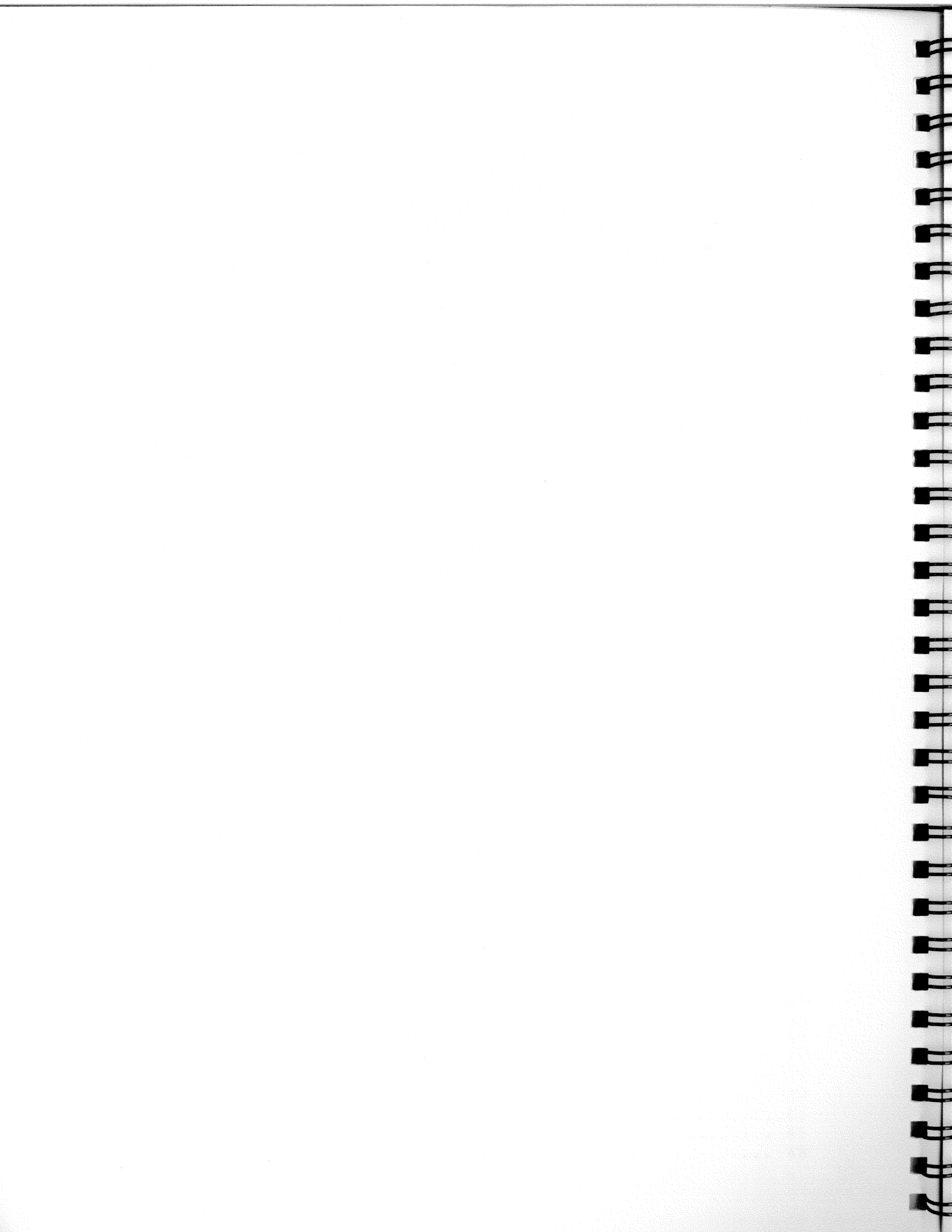

INTRODUCTION

PURPOSE

This pocket service guide describes the following topics relevant to servicing the VT220 video terminal.

Testing and troubleshooting the field replaceable units (FRU)
FRU removal and replacement
Video monitor alignment
Related documentation
Cable information
Physical functional diagrams

Notes, Cautions, and Warnings

Notes, cautions, and warnings appear throughout this pocket service guide. They are defined as follows:

Note: Contains an important message alerting you to information you should be aware of.

Caution: Contains information essential to the safety of the equipment and software.

Warning: Contains information essential to the safety of personnel.

PRODUCT

The VT220 is a 1/4 page, customer installable, conversational terminal featuring VT102 compatibility.

The VT220 terminal supports multiple language versions of the LK201 corporate keyboard. The VT220 has an anti-glare monochromatic 12-inch (305 mm) monitor and is capable of displaying 24 rows of text in either 80- or 132-column formats. The ergonomically designed monitor tilt mechanism permits the user to adjust the screen for optimum viewing comfort.

The VT220 features three standard interface connectors: two asynchronous serial ports and one 20 mA port. The EIA host port is a 25-pin (EIA RS-232-C) male connector, which is one method used to connect the terminal to the host computer. The 20 mA host port, which is an 8-pin 20 mA female connector, is another method of connecting the VT220 to the host computer. The third interface connector is the printer port, which is a 9-pin (EIA RS-232-C) male connector used to connect the terminal to a hard-copy printer. The VT220 terminal operates only on full-duplex asynchronous communication lines.

TOOLS REQUIRED

The following tools are required to service the VT220 video terminal.

| Tool | Part Number |
|-------------------------------|-------------|
| VOM (volt ohmmeter) | 29-13510-00 |
| Slotted screwdriver, 1/4 inch | 29-10983-00 |
| Phillips screwdriver, no. 2 | 29-11005-00 |
| Tuning wand | 29-23189-00 |
| Video alignment tool | 29-23190-00 |
| Oclifilter cleaner | 49-01607-01 |
| Diagonal cutters | 29-10206-00 |
| Anode discharge tool | 29-24717-00 |
| Keycap removal tool | 74-27314-01 |
| Scribe | None |
| Flexible plastic ruler | None |

1
TESTING AND TROUBLESHOOTING
THE VT220 VIDEO TERMINAL

1.1 GENERAL

This chapter contains the information needed to perform the self-test functions and troubleshoot the VT220 video terminal.

1.2 TESTING AND TROUBLESHOOTING

There are a series of internal self-tests to help you isolate failures to the field replaceable units (FRUs). (See Appendix B.) These tests are designed to address 95% of the VT220's functionality. They are listed in Table 1-1.

If a test discloses a faulty FRU, adjust or replace the faulty unit. After adjusting or replacing a FRU, repeat all of the tests listed in Table 1-1 to ensure that the terminal operates properly.

Table 1-1 Self-Test Chart

| Self-Tests | Prerequisites | Sequence (See Note) |
|---|---|--|
| Power-up self-test (Para. 1.3) | None | Turn terminal power on. |
| Power-up self-test (Invoked after terminal is operating) | <ul style="list-style-type: none"> ● SET-UP - Local - VT100 | Once: ESC [4 ; 1 y Continuously: ESC [4 ; 1 ; 9 y |
| EIA Port Data Lines Loopback Self-Test (Para. 1.4) | <ul style="list-style-type: none"> ● SET-UP - Local - VT100 ● EIA loopback connector | Once: ESC [4 ; 2 y Continuously: ESC [4 ; 2 ; 9 y |
| Printer Port External Loopback Self-Test (Para. 1.5) | <ul style="list-style-type: none"> ● SET-UP - Local - VT100 ● Printer port loopback connector | Once: ESC [4 ; 3 y Continuously: ESC [4 ; 3 ; 9 y |
| EIA Port Control Lines Loopback Self-Test (Para. 1.6) | <ul style="list-style-type: none"> ● SET-UP - Local - VT100 ● EIA loopback connector | Once: ESC [4 ; 6 y Continuously: ESC [4 ; 6 ; 9 y |
| 20 mA Port Loopback Self-Test (Para. 1.7) | <ul style="list-style-type: none"> ● SET-UP - Local - VT100 ● 20 mA loopback connector | Once: ESC [4 ; 7 y Continuously: ESC [4 ; 7 ; 9 y |
| Screen Alignment Self-Test (Para. 1.8) | | ESC # 8 |
| Execute all above tests except 20 mA Port Loopback test and screen alignment display pattern. | See individual tests | ESC [4 ; 0 y |

NOTE:

Do not type spaces between the parameters of any escape sequence. The parameters are spaced as shown for clarity only.

1.3 POWER-UP SELF-TEST

The power-up self-test checks the terminal's internal memory, the keyboard, the video circuitry, and makes a partial check of the communication and printer ports to see if they are operating properly.

A successful power-up self-test ends when:

- (1) the keyboard LED indicators (See Figure 1-1.) are off;
- (2) the keyboard generates a bell tone; and
- (3) a "VT220 OK" message enclosed by a rectangle appears on the screen. (See Figure 1-1.) This message will disappear from the screen the moment any character except XON is received by your terminal, if you press the SET-UP key, or if you let 30 minutes elapse.

Should an error occur, check your monitor first. Your monitor will display "VT220" accompanied by an error message on the screen. The error message will be defined in Table 1-2. (See Paragraph 1.10.)

If an error occurs that makes it impossible for you to continue operating your monitor, the keyboard LED indicators will display the error code, which will be defined in Table 1-3. (See Paragraph 1.10.)

Should a problem occur, consult Paragraph 1.11 where Table 1-4 relates common symptoms and their probable causes and suggests appropriate corrective actions.

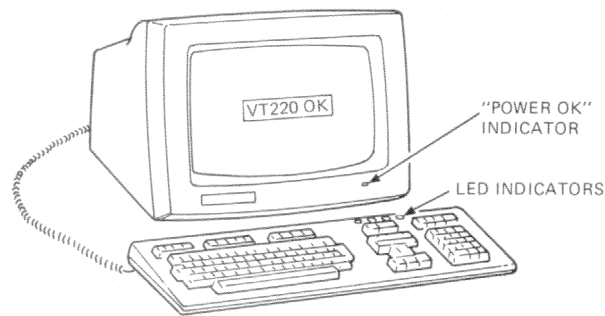

MA 0841-83

Figure 1-1 Indication of Successful Self-Test

Table 1-2 VT220 Monitor Display Error Coding

| Error Message | Corrective Action |
|------------------------------------|---|
| VT220 NVR Error -- 1 | Replace terminal controller board |
| VT220 EIA Port Data Error -- 2 | Replace terminal controller board |
| VT220 EIA Port Controls Error -- 3 | Replace terminal controller board |
| VT220 Keyboard Error -- 4 | <ol style="list-style-type: none"> 1. Check to see if keyboard is plugged in. 2. Replace keyboard. 3. Replace terminal controller board. |
| VT220 20 mA Port Error -- 5 | <ol style="list-style-type: none"> 1. Replace terminal controller board. 2. Replace power supply/monitor board. |
| VT220 Printer Port Error -- 6 | <ol style="list-style-type: none"> 1. Replace terminal controller board. 2. Replace power supply/monitor board. |

Table 1-3 VT220 LED Error Reporting

The keyboard LED indicators will flash repeatedly: on for one second, off for one-third of a second in the following patterns:

| L1 HOLD | LED Display L2 LOCK | L3 COMPOSE | L4 WAIT | Replace* |
|------------|---------------------------|---------------|------------|------------|
| o | o | o | o | Controller |
| o | o | o | ● | Controller |
| o | o | ● | o | Controller |
| o | o | ● | ● | Controller |
| ● | o | o | o | Controller |
| ● | o | o | ● | Controller |
| ● | o | ● | o | Controller |
| ● | o | ● | ● | Controller |
| ● | ● | o | o | Controller |
| ● | ● | o | ● | Controller |
| ● | ● | ● | o | Controller |
| ● | ● | ● | ● | Controller |
| X | X | X | X | Keyboard† |

* To replace terminal controller, see Paragraph 2.3.

† X denotes a varying LED display that repeats one of the above LED patterns. To replace keyboard, see Paragraph 2.7.

NOTE

● = on, o = off

Start the power-up self-test with one of the following two methods:

1. Turn the power to the VT220 on (the power-up self-test is invoked automatically each time the terminal is turned on);
2. Or type one of the following sequences to conduct the power-up self-test. (Read the following NOTE first.)

NOTE

If you are already operating your terminal, enter SET-UP and put your terminal in local and in the VT100 mode.

ESC [4 ; 1 y (Performs test once)

ESC [4 ; 1 ; 9 y (Performs test continuously)

NOTE

The continuously running test ends only if an error occurs or the power is turned off. The keyboard does not generate a bell tone during a continuously running test.

When you invoke the power-up self-test:

- All keyboard LED indicators will flicker on and off intermittently.
- You will hear a bell tone if the test is completed successfully, and
- A "VT220 OK" message enclosed by a rectangle will appear on the screen.

1.4 EIA PORT DATA LINES LOOPBACK SELF-TEST

In the EIA port data lines loopback self-test, the terminal's transmit and receive lines are connected together with a data loopback connector. (See Figure 1-2.) The terminal transmits a predefined set of characters on its transmit line and receives them on its receive line. It then compares the output characters to the input characters and displays an error message on the screen if the characters do not match. (See Paragraph 1.10.)

A successful test ends when:

- (1) the keyboard LED indicators are off;
- (2) the keyboard generates a bell tone; and
- (3) a "VT220 OK" message enclosed by a rectangle appears on the screen.

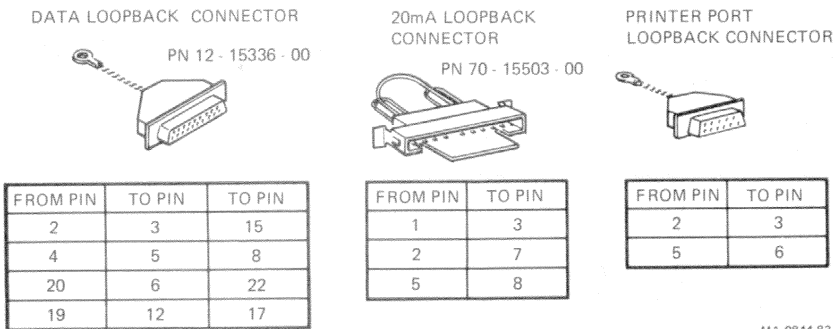
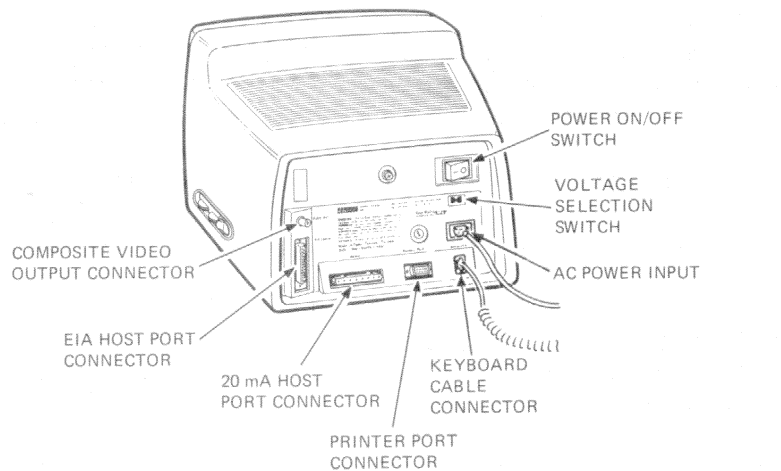

MA-0844-83

Figure 1-2 Rear Connector Panel of VT220

Perform the following steps to run the EIA data lines loopback self-test.

1. Enter SET-UP and put your terminal in local and in the VT100 mode.
2. Connect the data loopback connector (PN 12-15336-00) to the host port. (See Figure 1-2.)
3. Type one of the following sequences to perform the data loopback self-test.

ESC [4 ; 2 y (Performs test once)

ESC [4 ; 2 ; 9 y (Performs test continuously)

NOTE

The continuously running test ends only if an error occurs or the power is turned off. The keyboard does not generate a bell tone during a continuously running test.

If the EIA port data lines loopback self-test finds an error, your terminal will display "VT220 EIA Port Data Error -- 2" on the screen. (See paragraph 1.10.)

1.5 PRINTER PORT EXTERNAL LOOPBACK SELF-TEST

In the printer port loopback self-test, the printer port transmit and receive lines are connected together using the printer port loopback connector. (See Figure 1-2.) The terminal transmits a predefined set of characters on its transmit line and receives them on its receive line. Then it compares the input characters with the output characters. If they do not match, it displays an error message on the screen. (See Paragraph 1.10.)

A successful test ends when:

- (1) the keyboard LED indicators are off;
- (2) the keyboard generates a bell tone; and
- (3) a "VT220 OK" message enclosed by a rectangle appears on the screen.

Perform the following steps to run the printer port loopback self-test.

1. Enter SET-UP and put your terminal in local and in the VT100 mode.
2. Connect the printer port loopback connector to the printer port. (See Figure 1-2.)
3. Type one of the following sequences to perform the printer port external loopback test.

ESC [4 ; 3 y (Performs test once)

ESC [4 ; 3 ; 9 y (Performs test continuously)

NOTE

The continuously running test ends only if an error occurs or the power is turned off. The keyboard does not generate a bell tone during a continuously running test.

If the printer port loopback self-test finds an error, your terminal will display "VT220 Printer Port Error -- 6" on the screen. (See Paragraph 1.10.)

1.6 EIA PORT CONTROL LINES LOOPBACK SELF-TEST

This procedure tests data terminal ready, request to send, carrier detect, data set ready, and clear to send.

A successful test ends when:

- (1) the keyboard LED indicators are off;
- (2) the keyboard generates a bell tone; and
- (3) a "VT220 OK" message enclosed by a rectangle appears on the screen.

Perform the following steps to run the EIA port control lines loopback self-test.

1. Enter SET-UP and put your terminal in local and in the VT100 mode.
2. Install EIA loopback connector (PN 12-15336-00) to EIA host port. (See Figure 1-2.)
3. Type one of the following sequences to perform the EIA port control lines loopback self-test.

ESC [4 ; 6 y (Performs test once)

ESC [4 ; 6 ; 9 y (Performs test continuously)

NOTE

The continuously running test ends only if an error occurs or the power is turned off. The keyboard does not generate a bell tone during a continuously running test.

If the EIA port control lines loopback self-test finds an error, your terminal will display "VT220 EIA Port Controls Error -- 3" on the screen. (See Paragraph 1.10.)

1.7 20 mA PORT LOOPBACK SELF-TEST

In the 20 mA port loopback self-test, the terminal's transmit and receive lines are connected together with a 20 mA data loopback connector. (See Figure 1-2.) The terminal transmits a predefined set of characters on its transmit line and receives them on its receive line. It then compares the output characters to the input characters and displays an error message on the screen if the characters do not match. (See Paragraph 1.10.)

A successful test ends when:

- (1) the keyboard LED indicators (See Figure 1-1.) are off;
- (2) the keyboard generates a bell tone; and
- (3) a "VT220 OK" message enclosed by a rectangle appears on the screen.

Perform the following steps to run the 20 mA port loopback self-test.

1. Enter SET-UP and put your terminal in local and in the VT100 mode.
2. Connect the 20 mA loopback connector (PN 70-15503-00) to 20 mA port. (See Figure 1-2.)
3. Type one of the following sequences.

ESC [4 ; 7 y (Performs test once)

ESC [4 ; 7 ; 9 y (Performs test continuously)

NOTE

The continuously running test ends only if an error occurs or the power is turned off. The keyboard does not generate a bell tone during a continuously running test.

If the 20 mA port loopback self-test finds an error, your terminal will display "VT220 20 mA Port Error -- 5" on the screen. (See Paragraph 1.10.)

1.8 SCREEN ALIGNMENT TEST

The screen alignment test fills the screen with uppercase Es for making display height, width and linearity adjustments.

Perform the following steps to conduct the screen alignment self-test.

1. Enter SET-UP and put terminal in:
 - a. 80 columns per line
 - b. VT100 mode
 - c. Local
 - d. Reverse video
2. Type ESC # 8. (Your screen will display all capital Es in reverse video.)
3. Refer to Chapter 3 for a complete description of all monitor adjustments used with this test pattern.
4. To remove the test pattern from the screen, enter SET-UP and select "CLEAR DISPLAY."

1.9 PRINTER PROBLEMS

If the printer does not print, perform the following steps to isolate the problem to the printer or to the video terminal.

1. Perform the power-up self-test. (See Paragraph 1.3.) If the terminal passes the self-test, go to step 2.
2. Perform the printer port external loopback self-test. (See Paragraph 1.5.) If your terminal passes this test, go to step 3.

NOTE

If your terminal passes the above tests, it is running correctly; the problem is not a malfunctioning terminal.

3. Test the printer. (Consult your printer pocket service guide for the correct procedure.) If your printer is operational, proceed to step 4.
4. Check the following SET-UP features to make certain that your VT220 terminal and printer are compatible.
 - Baud rate (VT220 and printer)
 - Data bits per character (VT220 and printer)
 - Parity (VT220 and printer)
 - "Printer Ready" must appear on VT220 SET-UP status line
 - Printer must be set to "Full Duplex"
5. Check for correct cable between your terminal and the printer. (See Appendix C.) Make certain the connectors are securely fastened at both ends of the cable.
6. Type the following sequence:

ESC # 8 (Your video screen should display a test pattern of uppercase Es.)
7. Press the PRINT SCREEN key. The video display should be printed out on the printer if the printer is operating correctly.

1.10 SELF-TEST ERROR CODES

Should your monitor display an error message on the screen, refer to Table 1-2. Each error message includes a reference to the FRU that must be replaced to correct the problem.

In the event of a video problem refer to Table 1-3 where the encoding for the LED indicators (See Figure 1-1.) will disclose the faulty component. The LED indicators will always display the error code for the test currently being run. Only upon completing this test successfully will your VT220 terminal clear the error readout.

Refer to Table 1-4 for other troubleshooting procedures.

1.11 TROUBLESHOOTING MISCELLANEOUS PROBLEMS

Table 1-4 relates common symptoms to their probable causes and suggests appropriate corrective actions.

Table 1-4 VT220 Troubleshooting Chart

| Symptom | Probable Cause | Corrective Action |
|---|--|---|
| NO "VT220 OK" DISPLAY "POWER OK" INDICATOR OFF NO KEYBOARD BELLTONE | Not plugged in, or no power at wall outlet | Plug in VT220, or try another wall outlet |
| | Power fuse | Replace fuse |
| | AC power cord | Check for opens/shorts |
| | Power supply | Replace power supply/monitor board |
| NO "VT220 OK" DISPLAY "POWER OK" INDICATOR ON NO KEYBOARD BELLTONE | Terminal controller board | Replace terminal controller board |
| NO "VT220 OK" DISPLAY "POWER OK" INDICATOR ON KEYBOARD BELLTONE PRESENT | Brightness set too low | Adjust contrast and brightness controls |
| | Terminal controller board | Replace terminal controller board |
| | Monitor board | Replace power supply/monitor board |
| | Flyback transformer | Replace flyback transformer |
| | CRT and yoke | Option, swap the entire VT220 terminal |
| "VT220 "OK" DISPLAY PRESENT "POWER OK" INDICATOR ON KEYBOARD BELLTONE PRESENT VT220 CANNOT COMMUNICATE WITH HOST | VT220 to host port connection loose | Check to see if host plugged in |
| | Terminal controller to power supply/monitor board connection | Check terminal controller to power supply/monitor board connector |
| | Host port circuits faulty | Run EIA or 20 mA loopback test |

Table 1-4 VT220 Troubleshooting Chart (Cont)

| Symptom | Probable Cause | Corrective Action |
|---|---|--|
| RANDOM CHARACTERS APPEAR ON SCREEN | Terminal controller board | Replace terminal controller board |
| HORIZONTAL OR VERTICAL LINE APPEARS ON SCREEN | Monitor connectors | Check and reconnect |
| | Monitor circuit | Replace power supply/monitor board |
| | CRT and yoke | Option, swap the entire VT220 terminal |
| SCREEN DISPLAY DISTORTED | Monitor is out of alignment | Align monitor |
| | Monitor circuit | Replace power supply/monitor board |
| | Terminal controller board | Replace terminal controller board |
| | CRT and yoke | Option, swap the entire VT220 terminal |
| SCREEN DISPLAY JITTERY | Flyback transformer | Replace flyback transformer |
| NO BELLTONE FROM KEYBOARD | Keyboard speaker faulty | Replace keyboard |
| DIFFERENT CHARACTERS APPEAR ON SCREEN THAN WERE TYPED ON KEYBOARD WHILE IN LOCAL | Alternate character set selected | Clear with RESET field in SET-UP |
| | Keyboard | Replace keyboard |
| | Terminal controller board | Replace terminal controller board |
| DIFFERENT CHARACTERS APPEAR ON SCREEN THAN WERE TYPED ON KEYBOARD WHILE ON LINE WITH HOST (TERM. OK IN LOCAL) | Transmit and receive speeds are set wrong | Set speeds to match host |
| | Bits per character set wrong | Set bits to match |
| | Parity is set wrong | Set parity to match host |
| | Stop bits set wrong | Set to match host |

Table 1-4 VT220 Troubleshooting Chart (Cont)

| Symptom | Probable Cause | Corrective Action |
|---|----------------------------|---|
| TERMINAL DISPLAY DOES NOT SCROLL "HOLD SCREEN" INDICATOR IS ON. | "Hold Screen" mode enabled | Press the "Hold Screen" key to disable |
| TERMINAL APPEARS "LOCKED" DOES NOT RESPOND TO DATA FROM HOST | | Clear terminal with "CLEAR COMM" field in SET-UP Turn ac power off then on again |
| SCREEN GOES BLANK AFTER SUCCESSFUL POWER UP, THEN IS INACTIVE FOR A HALF HOUR. "POWER OK" INDICATOR ON | CRT saver feature on | Press any key to reactivate screen |
| MESSAGES ARE INCOMPLETE | XON/XOFF not selected | Enable in SET-UP |
| | Terminal controller board | Replace terminal controller board |
| | Host port connections | Check host ports |
| TERMINAL DOES NOT RESPOND TO ESCAPE SEQUENCES | Incorrect mode selected | Select VT100 mode in SET-UP |

2
FRU REMOVAL AND
REPLACEMENT

2.1 GENERAL

The removal and replacement procedures of FRUs for the VT220 video terminal are described in this chapter. The Recommended Spares List is given in Paragraph 2.8.

2.2 ACCESS COVER

Perform the following steps to remove the terminal access cover. (See Figure 2-1.)

1. Turn the power to the terminal off.
2. Disconnect the power cord from the wall outlet. Remove the power cord from the terminal's power cord connector.
3. Disconnect the keyboard cable connector and the connector from the video output jack, if applicable.
4. Disconnect all other cables from the rear panel of your terminal, including:
 - EIA host port cable
 - 20 mA host port cable
 - printer port cable

NOTE

Before proceeding with step 5, place a piece of paper on a flat work surface to avoid scratching the monitor bezel. Carefully place the monitor face down on this paper.

The face of the CRT must be cleaned when you have finished servicing the monitor. Use the cleaning solution supplied with the monitor or use isopropyl alcohol.

5. With a scribe, remove the plastic cap on the rear panel of the access cover.
6. With a phillips screwdriver, remove the screw and washer that were exposed when you removed the cap. This screw helps secure the access cover to the terminal's chassis.
7. With the scribe, remove the two caps on the bottom side of the access cover.
8. Remove the screws and washers that were exposed when you removed these caps.

REMOVE THE
PLASTIC CAPS (3)

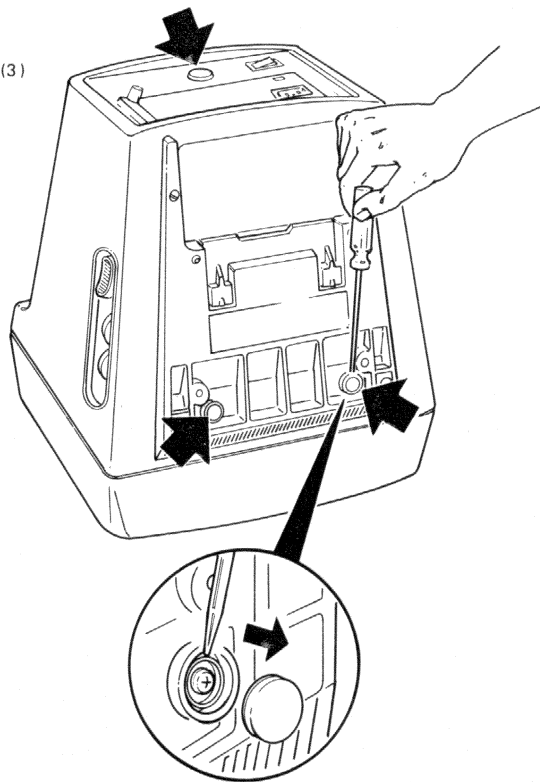

REMOVE THE PHILLIPS SCREWS (3)
AND WASHERS (3)

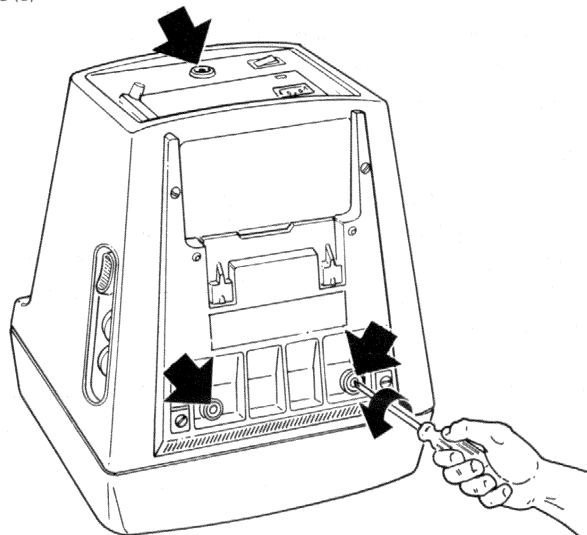

MA 0846-83

Figure 2-1 Removing the Screws on the Access Cover

9. Remove the access cover by sliding it straight up. (See Figure 2-2.)

WARNING

This procedure exposes you to the CRT anode, which may contain a stored high voltage. Use caution while the access cover is off of the terminal.

To install the access cover, perform steps 1--9 in reverse.

CAUTION

During installation, the access cover may require careful positioning to align the screw holes.

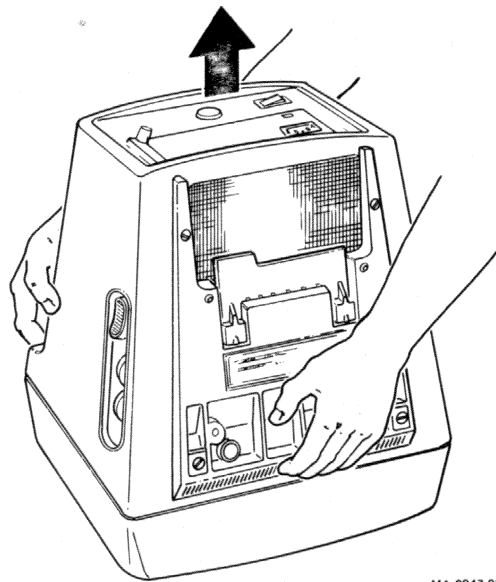

MA-0847-83

Figure 2-2 Removing the Access Cover

2.3 TERMINAL CONTROLLER BOARD

Perform the following steps to remove the terminal controller board.

1. Remove the access cover. (See Paragraph 2.2.)
2. Disconnect the flat cable going to the power supply/monitor board. (See Figure 2-3.)
3. Loosen the knurled captive grounding screw on the terminal controller board until it is held only by its retaining spring. (See Figure 2-3.)
4. Free the controller board from the three standoff fasteners by simultaneously lifting the board and squeezing each standoff fastener with needlenose pliers. (See Figure 2-3.)
5. To install the terminal controller board, perform steps 1--4 in reverse.

NOTE

When replacing the terminal controller board you should also replace the three standoffs used to mount the board to the chassis. Replacement standoffs are shipped with the replacement controller board.

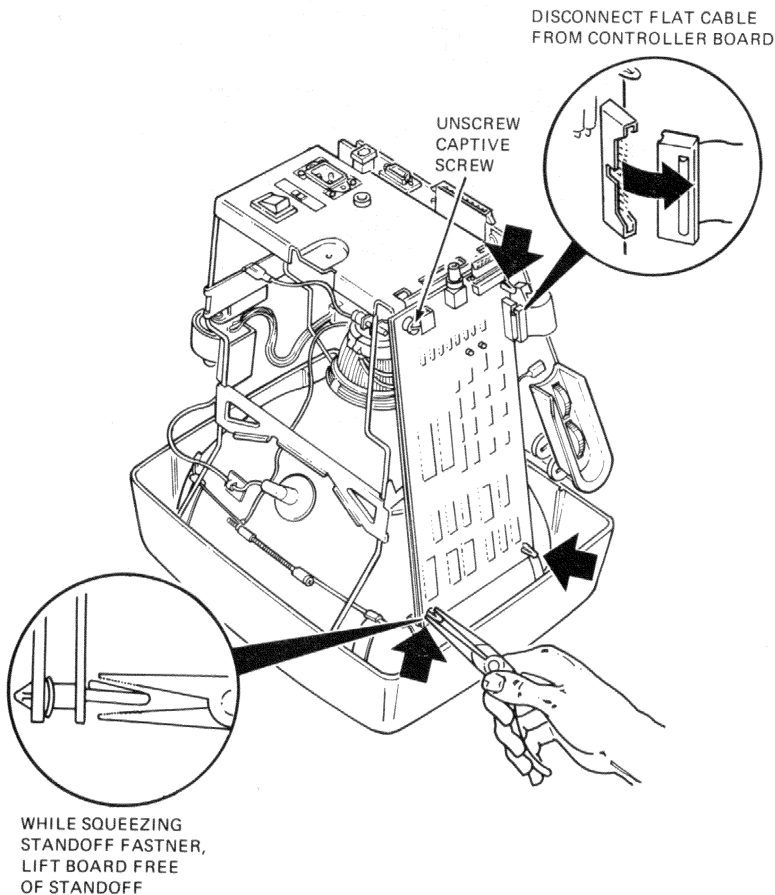

Figure 2-3 Removing the Terminal Controller Board

2.4 POWER SUPPLY/MONITOR BOARD

Perform the following steps to remove the power supply/monitor board.

WARNING

This procedure exposes you to the high voltage of the CRT and the power supply. Use caution while the access cover is off of the terminal.

1. Remove the access cover. (See Paragraph 2.2.)
2. Disconnect the 26-pin flat cable connector from the terminal controller board. (See Figure 2-4.)
3. Disconnect from the power supply/monitor board the 2-wire cable that runs to the "Power OK" indicator on the front bezel. (See Figure 2-4.)

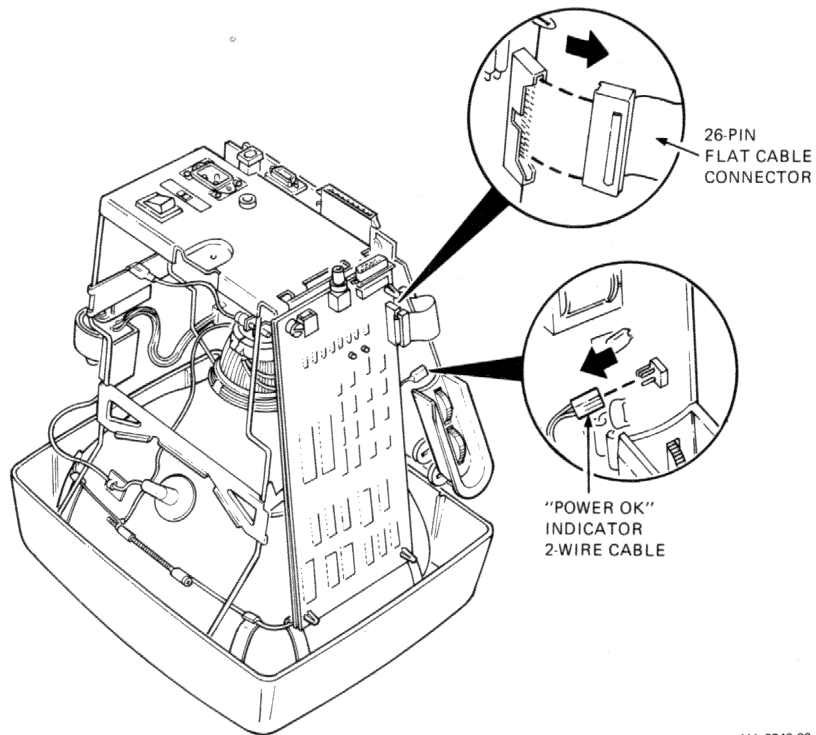

MA-0849-83

Figure 2-4 Disconnecting the Flat Cable and the "Power OK" Indicator 2-Wire Cable

4. Disconnect from the power supply/monitor board the 6-wire input cable that runs to the rear chassis panel. (See Figure 2-5.)
5. Disconnect from the power supply/monitor board the 7-wire cable that runs to the flyback transformer. (See Figure 2-5.)
6. Remove from the tab on the CRT ground loop clamp the white ground wire that runs to the round CRT connector. (See Figure 2-6.)
7. Remove the round CRT connector from the base of the CRT. (See Figure 2-6.)
8. Remove from the power supply/monitor board the four phillips screws that secure the board to the chassis. (See Figure 2-7.)

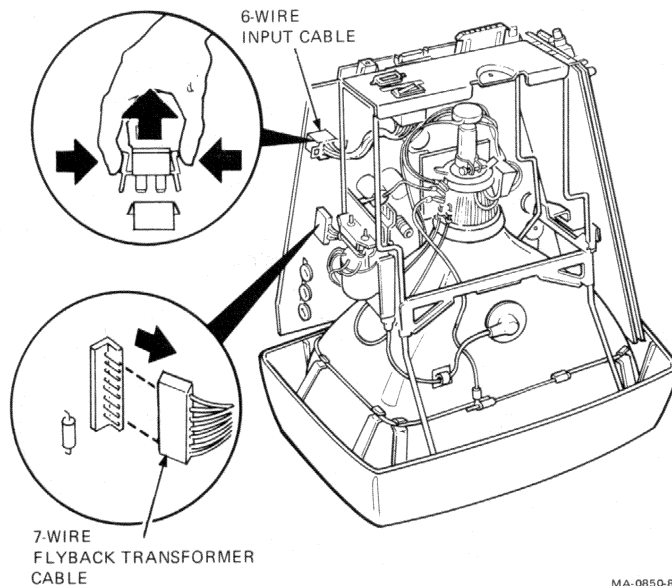
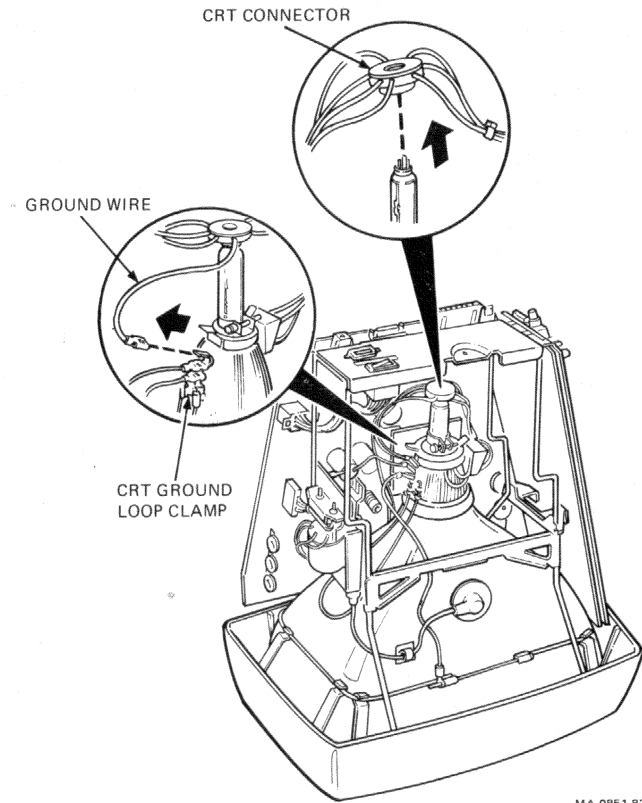
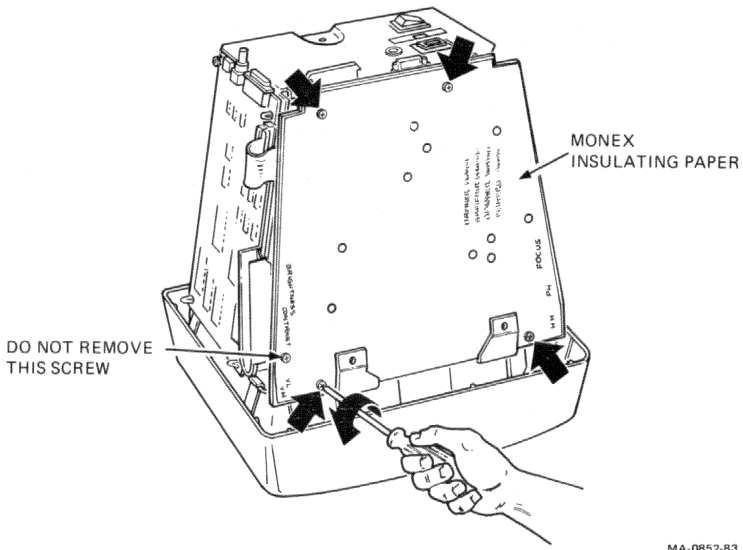

Figure 2-5 Disconnecting the 6-wire Input Cable and the 7-wire Cable to the Flyback Transformer



MA-0851-83

Figure 2-6 Removing the CRT Ground Wire and the Round CRT Connector



MA-0852-83

Figure 2-7 Removing the Screws from the Power Supply/Monitor Board

9. Cautiously move the power supply/monitor board away from the chassis to reveal the remaining connectors.
10. Untwist the white plastic clamp that secures the CRT round connector cable to the chassis. (See Figure 2-8.)
11. Disconnect the 4-wire cable that runs to the yoke of the CRT to free the power supply/monitor board. (See Figure 2-8.)

To install the power supply/monitor board, perform steps 1--11 in reverse.

NOTE

Make certain the CRT round connector cable will be within reach to install after the power supply/monitor board has been secured to the chassis with screws. When replacing the CRT round connector, make certain that it is seated firmly on the neck of the CRT.

CAUTION

To protect the components on the power supply/monitor board from short circuiting, make certain you reinstall the Monex insulating paper.

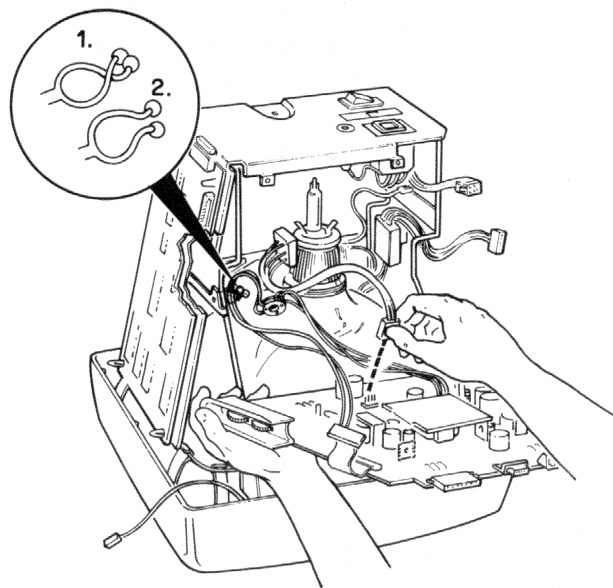

MA 0853-83

Figure 2-8 Freeing the CRT Round Connector Cable and Disconnecting the 4-wire Cable to the Yoke

2.5 FLYBACK TRANSFORMER

Perform the following steps to remove the flyback transformer.

1. Remove the access cover. (See Paragraph 2.2.)

WARNING

The following procedure exposes you to the CRT anode, which may contain a stored high voltage.

2. Discharge the CRT anode by performing the following steps. (See Figure 2-9.)
 - a. Attach the clip end of the anode discharge tool (PN 29-24717-00) to the metal chassis.

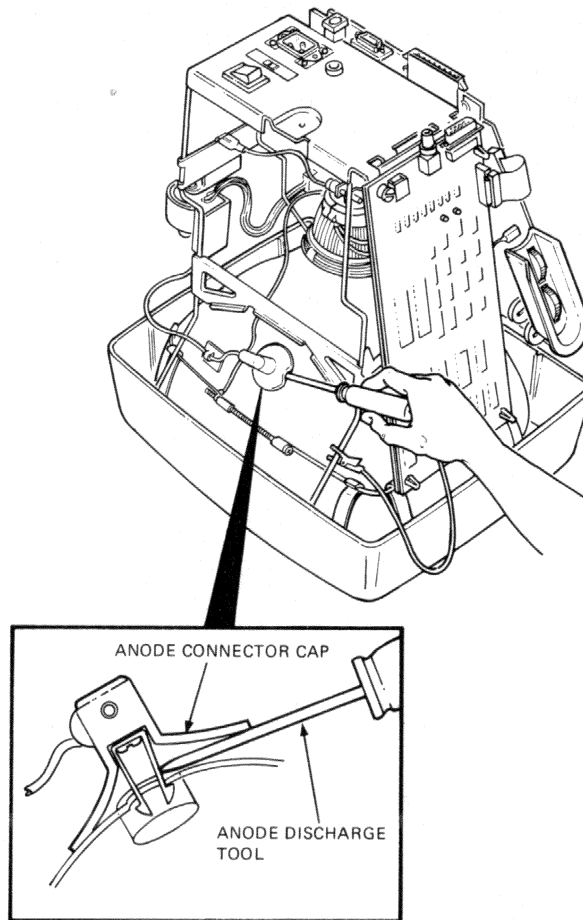

MA-0854-83

Figure 2-9 Discharging the CRT Anode

- b. Push the probe end under the soft plastic anode connector cap until you feel the probe touching the anode connector.

CAUTION

Do not scratch the glass of the CRT when discharging the anode.

- c. Hold the probe against the anode connector for at least 3 seconds, then remove the probe.
3. Cut the tie-wrap that secures the CRT anode wire to the CRT. (See Figure 2-10.)
4. Remove the CRT anode connector from the CRT. (See Figure 2-11.)
5. Disconnect the 7-wire connector from the power supply/monitor board. (See Figure 2-12.)
6. Using a 1/4 inch nut driver, remove the 2 nuts and 2 washers that hold the flyback transformer to the chassis. Remove flyback transformer. (See Figure 2-13.)
7. To install the flyback transformer perform steps 1 through 6 in reverse.

CAUTION

Don't forget to replace the tie-wrap that secures the anode wire to the CRT.

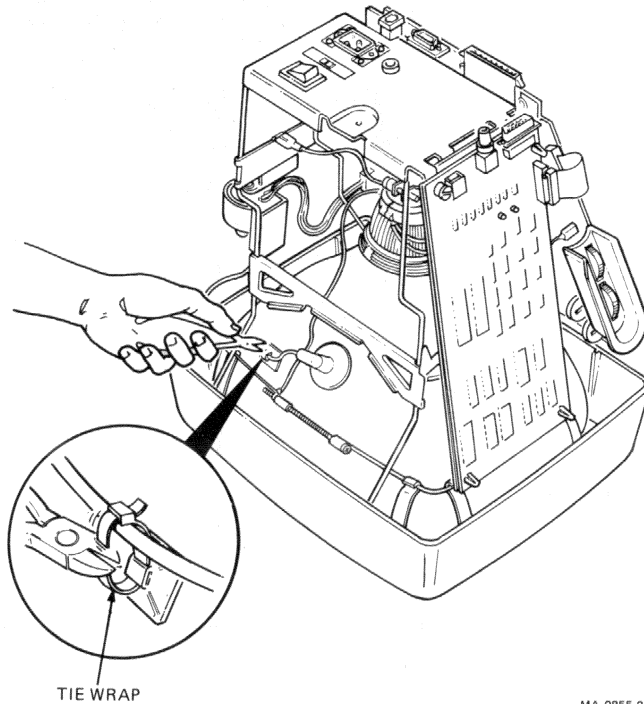
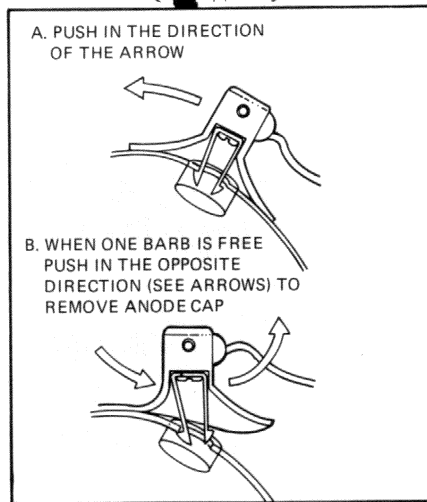
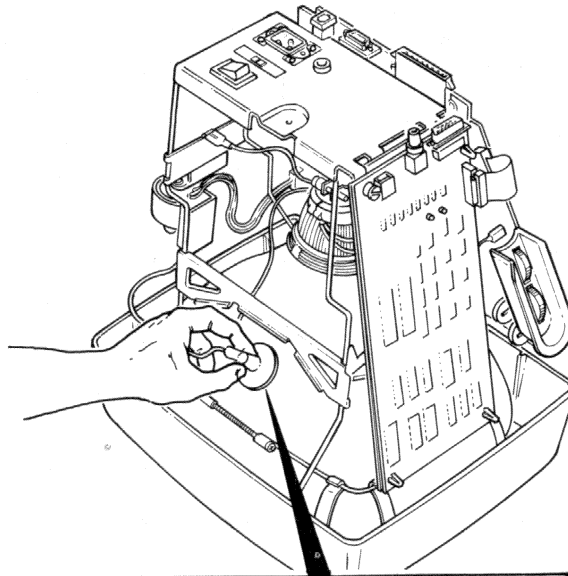
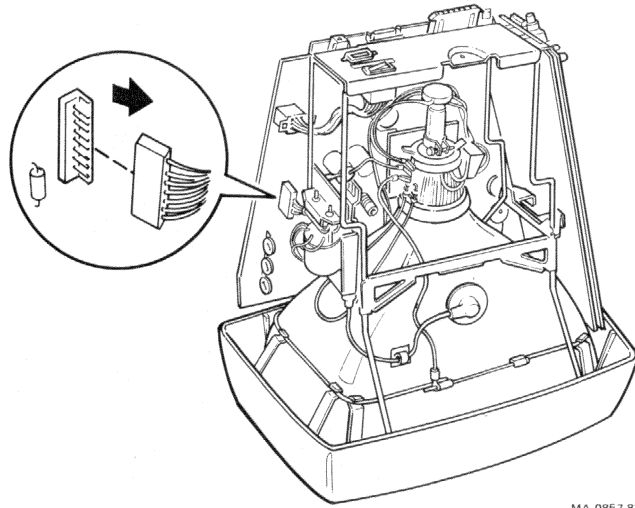

Figure 2-10 Cutting the Tie Wrap that Secures the Anode Wire



MA-0856-83

Figure 2-11 Removing the CRT Anode Connector from the CRT



MA-0857-83

Figure 2-12 Disconnecting the 7-wire Connector from the Power Supply/Monitor Board

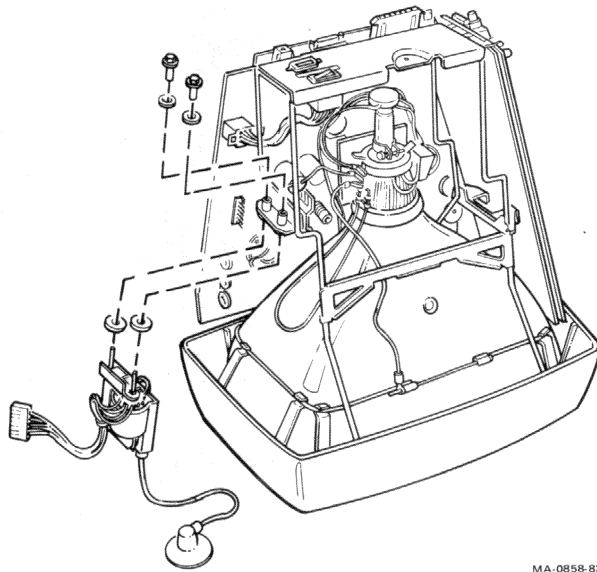

MA-0858-83

Figure 2-13 Removing the Flyback Transformer

2.6 CRT ASSEMBLY

If video alignment and adjustment did not correct the difficulty, exchange the entire VT220 terminal (whole option swap). Do not attempt to remove or repair any part of the CRT assembly in the field.

Perform the following steps to exchange the CRT assembly.

1. Set power switch to "0" (off position) before disconnecting cables from the rear panel of your terminal. (See Figure 2-14.)
2. Disconnect the following cables from the rear panel of your terminal, if applicable:
 - AC power cord
 - EIA host port cable
 - 20 mA host port cable
 - composite video output cable
 - video monitor cable
 - printer cable
 - keyboard cable
3. To install your new VT220 terminal perform steps 1 and 2 in reverse.

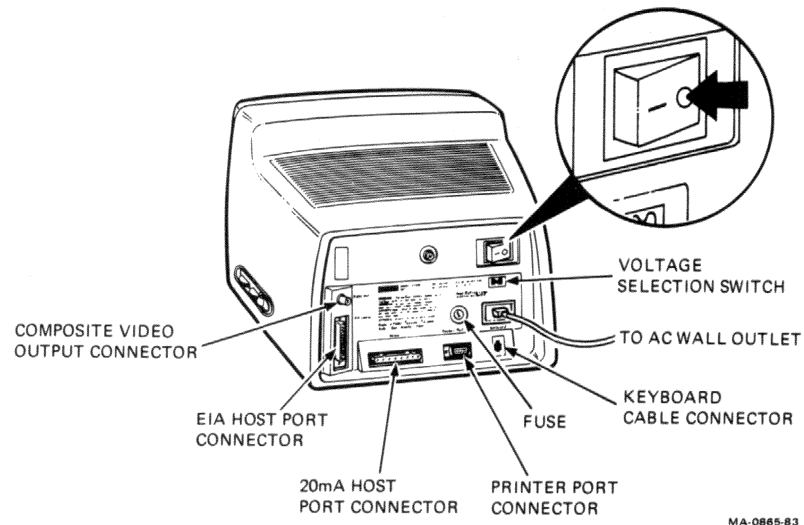

Figure 2-14 Rear Panel of VT220

2.7 KEYBOARD

If the keyboard is faulty, exchange the entire keyboard (whole option swap). Perform the following steps to remove the keyboard. (See Figure 2-15.)

1. Disconnect the keyboard cable from the cable connector on the rear panel of your VT220.
2. Remove the keyboard cable from the keyboard.

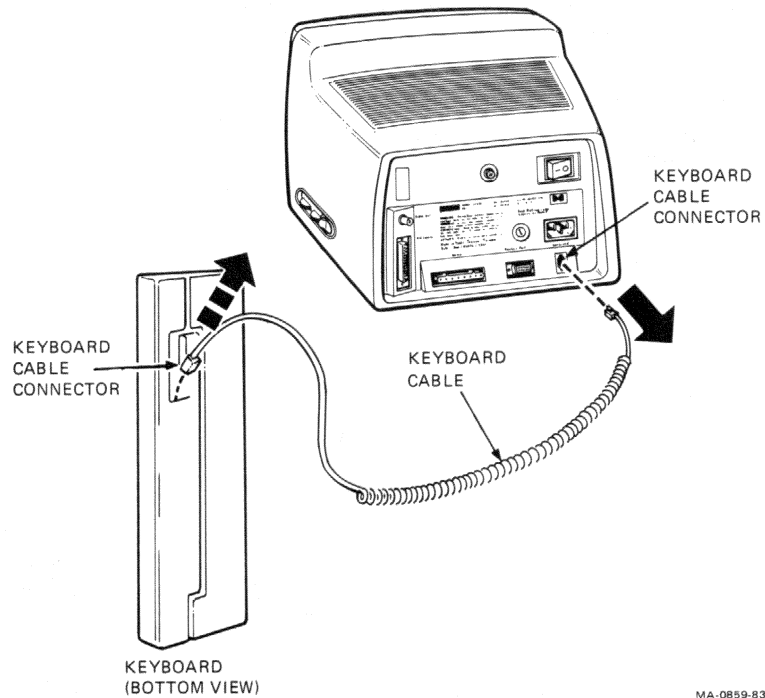
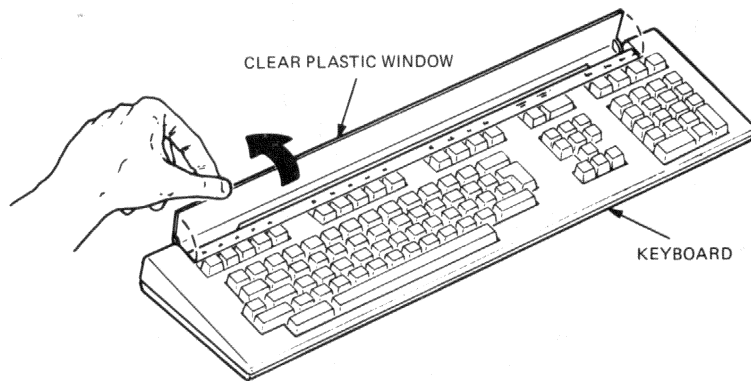

Figure 2-15 Removing the Keyboard

Perform the following steps to install the replacement keyboard. (See Figures 2-16 and 2-17.)

Install Legend Strip

1. Open clear plastic window.



2. Insert new legend strip directly over the one presently on the keyboard.

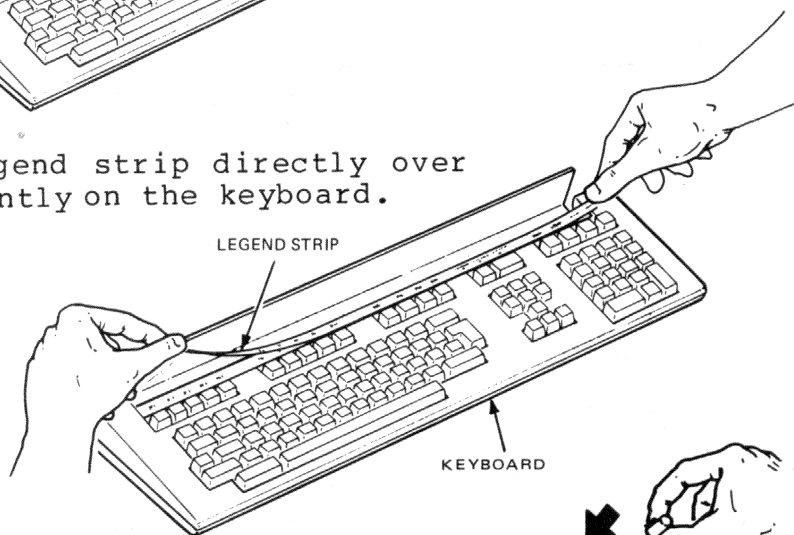

3. Close clear plastic window.

Install Keyboard Standoffs

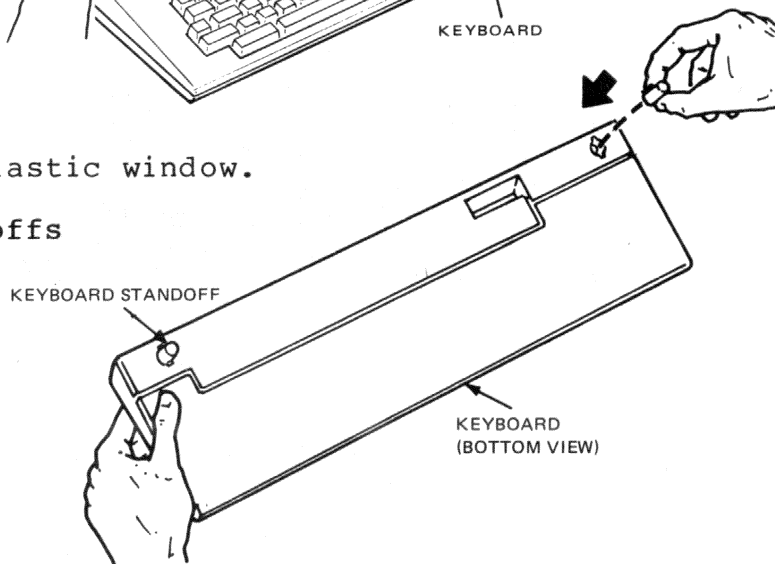

Figure 2-16 Installing the Legend Strip and Keyboard Standoffs

Connect Keyboard to Video Terminal

1. Insert longer end of keyboard cable into connector on bottom of keyboard.
2. Press cable into long groove if routing is to the left.
3. Press cable into short groove if routing is to the right.
4. Insert keyboard cable into connector on rear of terminal.

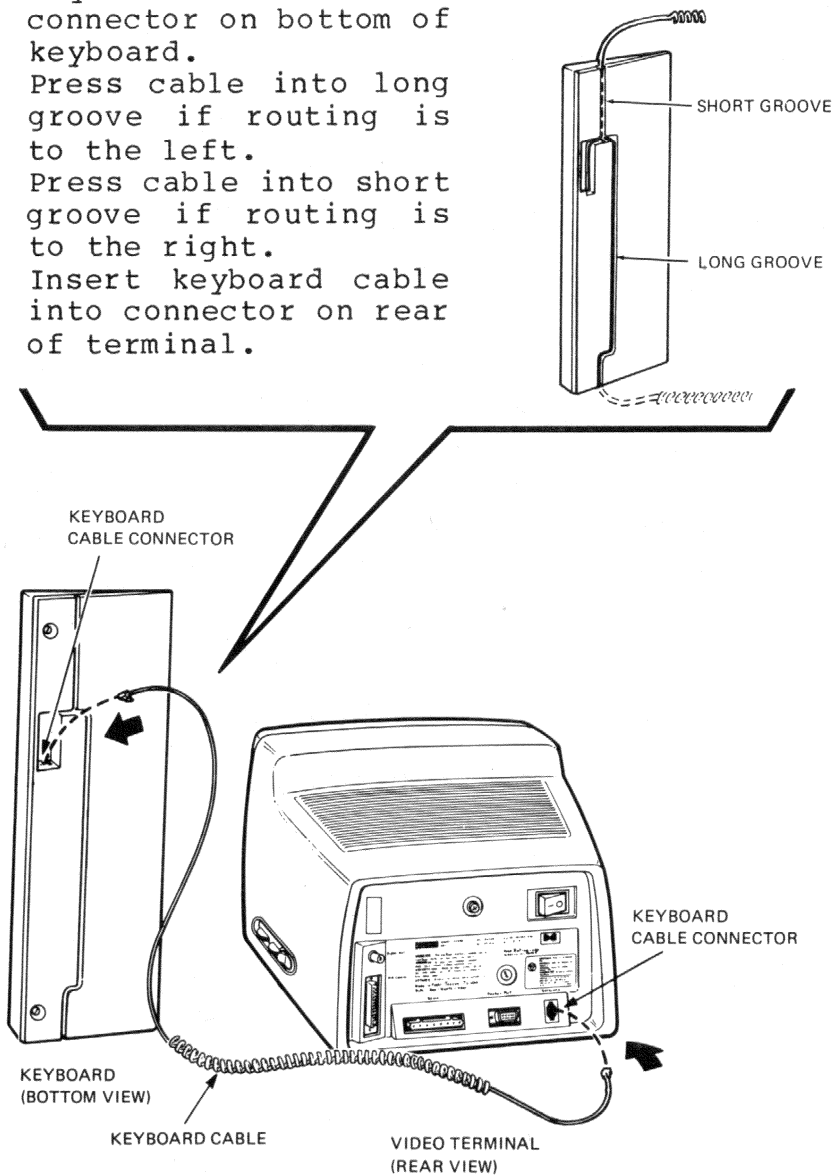

Figure 2-17 Installing the Replacement Keyboard

2.8 RECOMMENDED SPARES LIST

The recommended spares list for the VT220 is given in Table 2-1.

Table 2-1 Recommended Spares List

| Description | Part Number |
|----------------------------|--------------------------|
| Terminal controller | 70-20814-01 |
| Power supply/monitor board | 70-20624-01 |
| Flyback transformer | 70-20772-00 |
| CRT/bezel/yoke (white) | 70-20622-04 |
| (green) | 70-20622-05 |
| (amber) | 70-20622-06 |
| VT220-A (white) | VT220-A |
| VT220-B (green) | VT220-B |
| VT220-C (amber) | VT220-C |
| EIA loopback connector | 12-15336-00 |
| 20 mA loopback connector | 70-15503-00 |
| Printer port loopback | TBD |
| Keyboard | United States LK201-AA |
| Keyboard | Canada (French) LK201-AC |
| Keyboard | Denmark LK201-AD |
| Keyboard | United Kingdom LK201-AE |
| Keyboard | Finland LK201-AF |
| Keyboard | Austrian/German LK201-AG |
| Keyboard | Holland LK201-AH |
| Keyboard | Italy LK201-AI |
| Keyboard | Swiss (French) LK201-AK |
| Keyboard | Swiss (German) LK201-AL |
| Keyboard | Sweden LK201-AM |
| Keyboard | Norway LK201-AN |
| Keyboard | Belgium/French LK201-AP |
| Keyboard | Spain LK201-AS |

Table 2-1 Recommended Spares List (Cont)

| Description | Part |
|--|-------------|
| Keyboard Australia | LK201-AZ |
| Keycap removal tool | 74-27314-01 |
| Video alignment tool | 29-23190-00 |
| Tuning wand | 29-23189-00 |
| Fuse (U.S.) 3AG 2 Ampere rating | 90-07215-00 |
| Fuse carrier (U.S.) | 12-21126-03 |
| Fuse holder | 12-21126-01 |
| Fuse (European) | 12-19284-00 |
| Fuse carrier (European) | 12-201264 |
| Tie wraps | 90-09996-00 |

VIDEO MONITOR ALIGNMENT

3.1 GENERAL

The alignment procedure for the VT220 video monitor is described in this chapter. It will not be necessary to make all of the adjustments each time you align your monitor. However, many of the adjustments affect the other settings; therefore, all the adjustments should be checked. Then if a check discloses a correct setting, that adjustment can be omitted and you can go on to check the next setting.

All the adjustments must be made under the following conditions.

Enter SET-UP and put terminal in

- Reverse video mode (black characters on a white background)
- 80 columns per line
- VT100 mode
- Local.

Use a flexible metric ruler for determining alignment adjustments. Make certain that all adjustments are made under the conditions stated above.

3.2 MONITOR ADJUSTMENTS

The locations of the components where most of the adjustments will be made are shown in Figure 3-1.

3.2.1 Initial Preparations

1. Remove the access cover. (See Paragraph 2.2.)
2. Position your terminal as shown in Figure 3-1. Make certain that your monitor is on a nonconductive surface.
3. Reconnect the keyboard cable and power cord.
4. Turn the power switch on.
5. After "VT220 OK" appears on your screen, type ESC #8. (Your screen will display all capital Es.) This will be your alignment pattern.

NOTE

Your alignment pattern may not be distinct. Commence with the following alignment procedures to correct the problem.

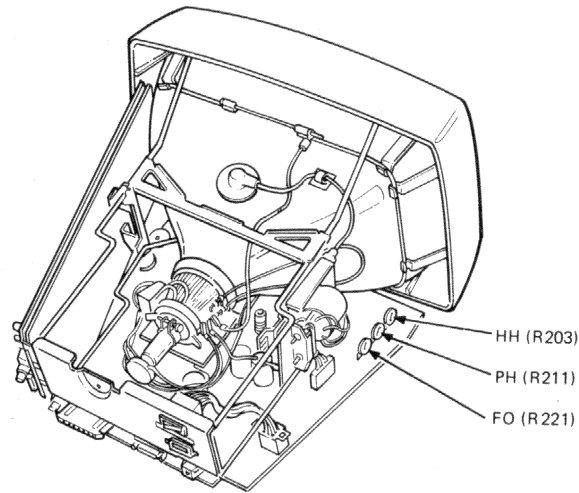
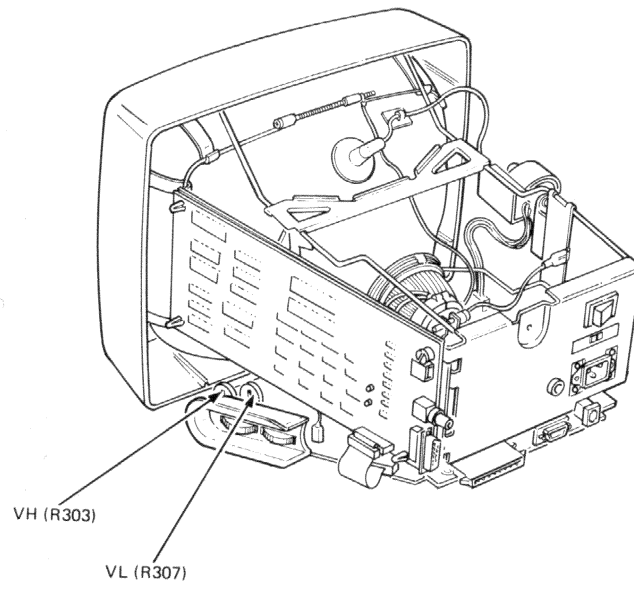

MA-0861-83

Figure 3-1 Video Adjustment Locations

3.2.2 Character Quality

3.2.2.1 Brightness -- Perform the following steps to adjust the brightness.

1. Permit the terminal to warm up for at least five minutes.
2. Increase both the brightness and the contrast to maximum. (See Figure 3-2 for the locations of the contrast and brightness controls.)
3. Decrease the brightness until the white diagonal lines (raster) just disappear.
4. Go to Paragraph 3.2.2.2.

3.2.2.2 CONTRAST -- Set the contrast control (see Figure 3-2) for the desired intensity of display relative to the background.

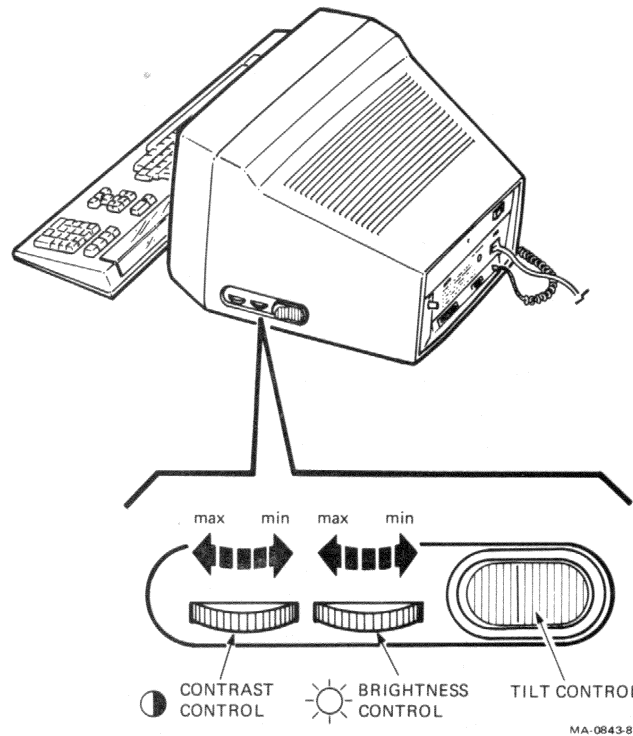

Figure 3-2 Brightness, Contrast, and Tilt Controls

3.2.2.3 Vertical Linearity -- Perform the following steps to check and adjust the vertical linearity.

1. Check the height of the characters at the four corners and at the center of the screen display. All of the characters should be the same height (3.7 ± 0.4 mm).
2. If necessary, adjust the vertical linearity (VL) control (See Figure 3-1.) until all of the characters, whether at the corners or in the center of the display, are the same height.
3. Go to Paragraph 3.2.2.4.

3.2.2.4 Focus -- Perform the following steps to check and adjust the focus.

1. Check the characters at the four corners and at the center of the screen display. The individual dots in the vertical segments of each E should be readily distinguishable.

NOTE

Make certain that the screen is clean and the filter (if any) is installed correctly. Either condition can appear to affect the focus.

In some instances, the operator may want the focus adjusted to suit personal preference. If the focus is adjusted as desired, go to step 3.

2. Adjust the focus (FO) control (See Figure 3-1.) for the best overall character presentation, if necessary.
3. Go to Paragraph 3.2.3.

3.2.3 Horizontal Hold (Display Instability Adjustment)

Perform the following steps to check and adjust the horizontal hold.

1. Examine the monitor display for tearing or any other signs of horizontal instability.
2. If necessary, adjust the horizontal hold (HH) control (See Figure 3-1.) to stabilize the display.
3. Go to Paragraph 3.2.4.

NOTE

There is no vertical hold adjustment.

3.2.4 Display Centering Adjustments

3.2.4.1 Horizontal Centering -- Perform the following steps to check and adjust the horizontal centering.

1. Measure the distance between the center of the left edge of the alignment pattern of Es on the screen and the monitor bezel. Use your flexible ruler to make this measurement. Make a note of the result.
2. Measure the distance between the center of the right edge of the alignment pattern of Es and the monitor bezel. Use your flexible ruler to make this measurement. Make a note of the result.
3. Compare the measurements taken in steps 1 and 2. If the difference between the two measurements is greater than 6 mm, adjust the horizontal centering control (PH). (See Figure 3-1.)

4. Perform steps 1 and 2 again to verify the adjustment.

NOTE

If the PH control adjusts the horizontal centering correctly, go to Paragraph 3.2.5.

5. Go to Paragraph 3.2.4.2.

3.2.4.2 Vertical Centering -- Perform the following steps to check and adjust vertical centering.

1. Measure the distance between the center character in the top row of Es and the monitor bezel. Use your flexible ruler to make this measurement. Make a note of the result.
2. Measure the distance between the center character in the bottom row of Es and the monitor bezel. Use your flexible ruler to make this measurement. Make a note of the result.
3. If the distance is less than 3 mm in either case, center the screen display by rotating the centering rings located on the neck of the CRT. Use the ring tabs to rotate these rings. (See Figure 3-3.)
4. Repeat Paragraph 3.2.4.2 to bring the horizontal centering control (PH) within range.

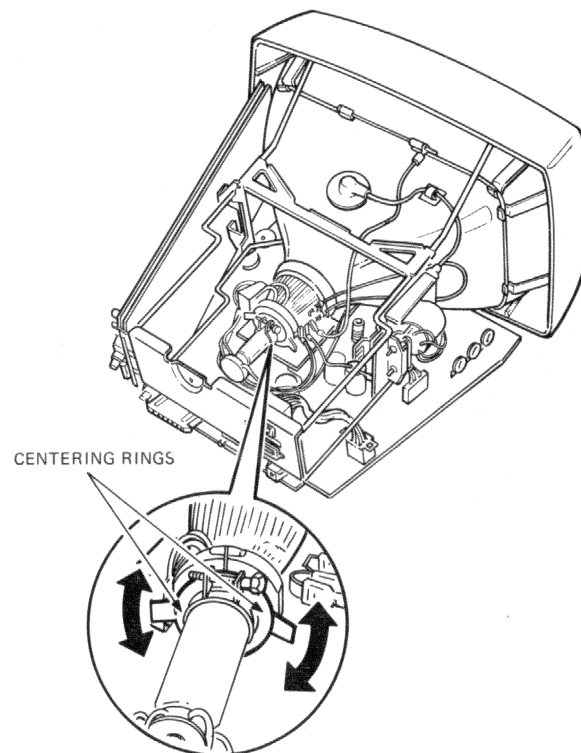

MA-0873-83

Figure 3-3 Centering Adjustments

3.2.5 Display Size

3.2.5.1 Horizontal Width -- Perform the following procedure to check and adjust the horizontal width.

Use your flexible ruler to measure the width of the alignment pattern of Es (one row of Es). If a single row of Es does not measure 203.2 mm, adjust the horizontal width (HW) control (L201) (See Figure 3-4.) with the tuning wand tool (PN 29-23189-00). Go to Paragraph 3.2.5.2.

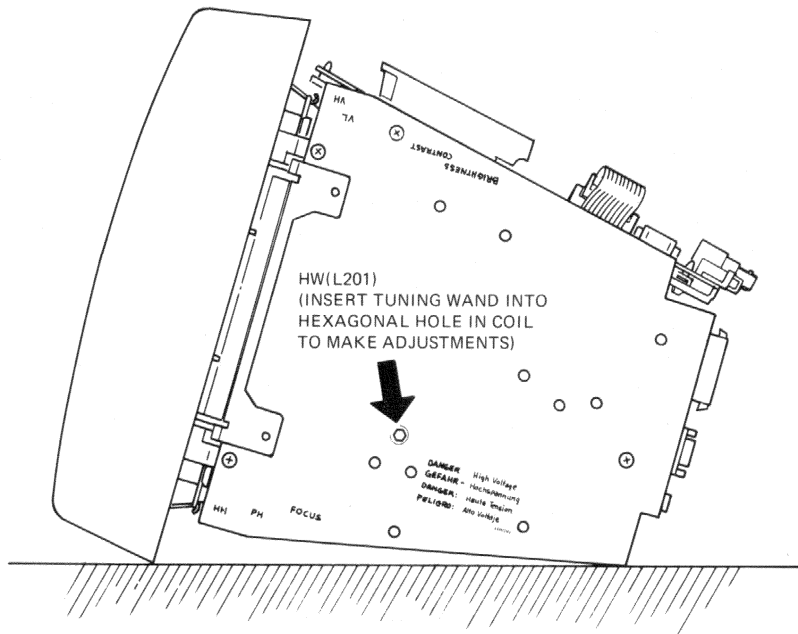

MA-0862-83

Figure 3-4 Horizontal Width Adjustment

3.2.5.2 Vertical Height

1. Use your flexible ruler to measure the height of the alignment pattern of Es (one column of Es). If a single column of Es does not measure 127 mm, adjust the vertical height (VH) control (See Figure 3-1.)
2. Readjust the vertical linearity, if necessary. (See Paragraph 3.2.2.3.)

4

SET-UP REFERENCE MATERIAL

Refer to the VT220 Owner's Manual for the SET-UP summaries for the VT220 video terminal.



APPENDIX A
VT220 DOCUMENTATION

All related documentation pertaining to the VT220 video terminal is included in the following list.

VT220 Owner's Manual EK-VT220-UG

This manual provides the user with the information needed to operate and service the VT220 terminal. The manual includes an overview of the VT220's physical and functional structure. Specific operational features such as SET-UP procedures, controls and indicators information, communication interfaces, and test functions are also described.

Installation Guide EK-VT220-IN

This guide provides the user with the information needed to unpack, assemble, and bring the VT220 terminal to operating status.

VT220 Programmer's Reference Manual EK-VT220-RM

This manual provides the programmer with all the information needed to use the communication and character processing features of the VT220 video terminal.

VT220 Programmer's Reference Card EK-VT220-RC

This card provides the programmer with a summary of the information needed to program the VT220 video terminal. Essentially, it is a list of the escape and control sequences on a pocket size reference card.

VT220 Pocket Service Guide EK-VT220-PS

This guide provides service personnel with the information needed to test, troubleshoot, and repair the VT220 video terminal.

VT220 Technical Manual

EK-VT220-TM

This manual provides the user with a technical description with which to isolate and repair VT220 problems that go beyond the FRU replacement level of repair. The manual includes an overview of both hardware and software components, and detailed descriptions of communications components and subsystems to the major circuit level.

VT220 Video Terminal IPB

EK-VT220-IP

This document is a detailed parts breakdown of the VT220 terminal's field replaceable units. This document does not contain part numbers for components on the printed circuit boards. However, these components are listed in the VT220 Field Maintenance Print Set, which is ordered separately.

VT220 Field Maintenance Print Set

MP-01732-01

This document provides the user with a complete set of electrical and mechanical schematic diagrams for the VT220 terminal.

APPENDIX B

FRU EXPLODED VIEW DRAWINGS

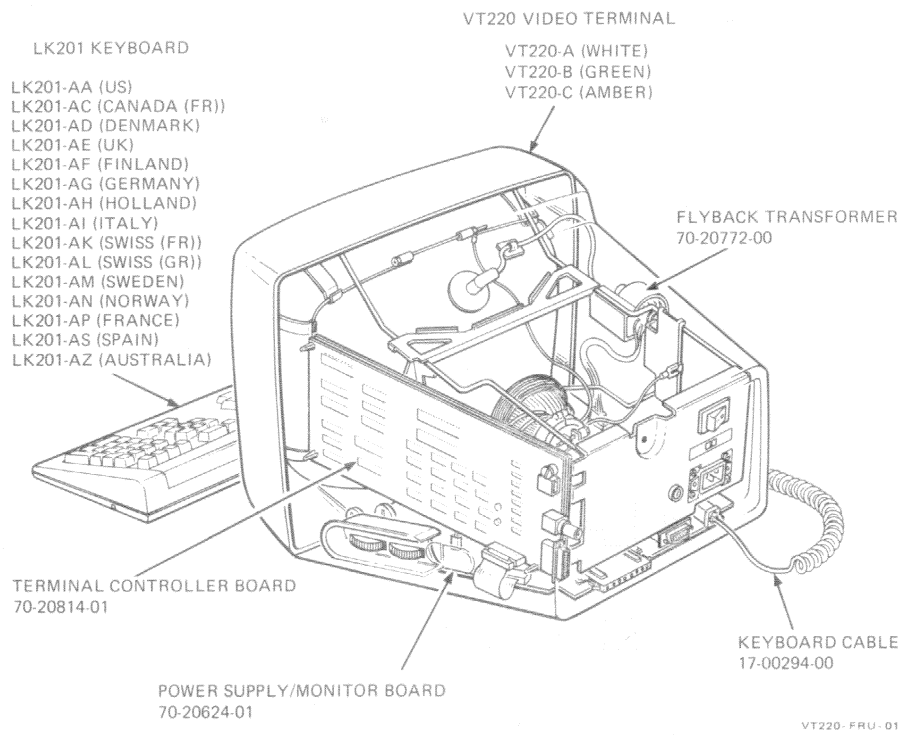
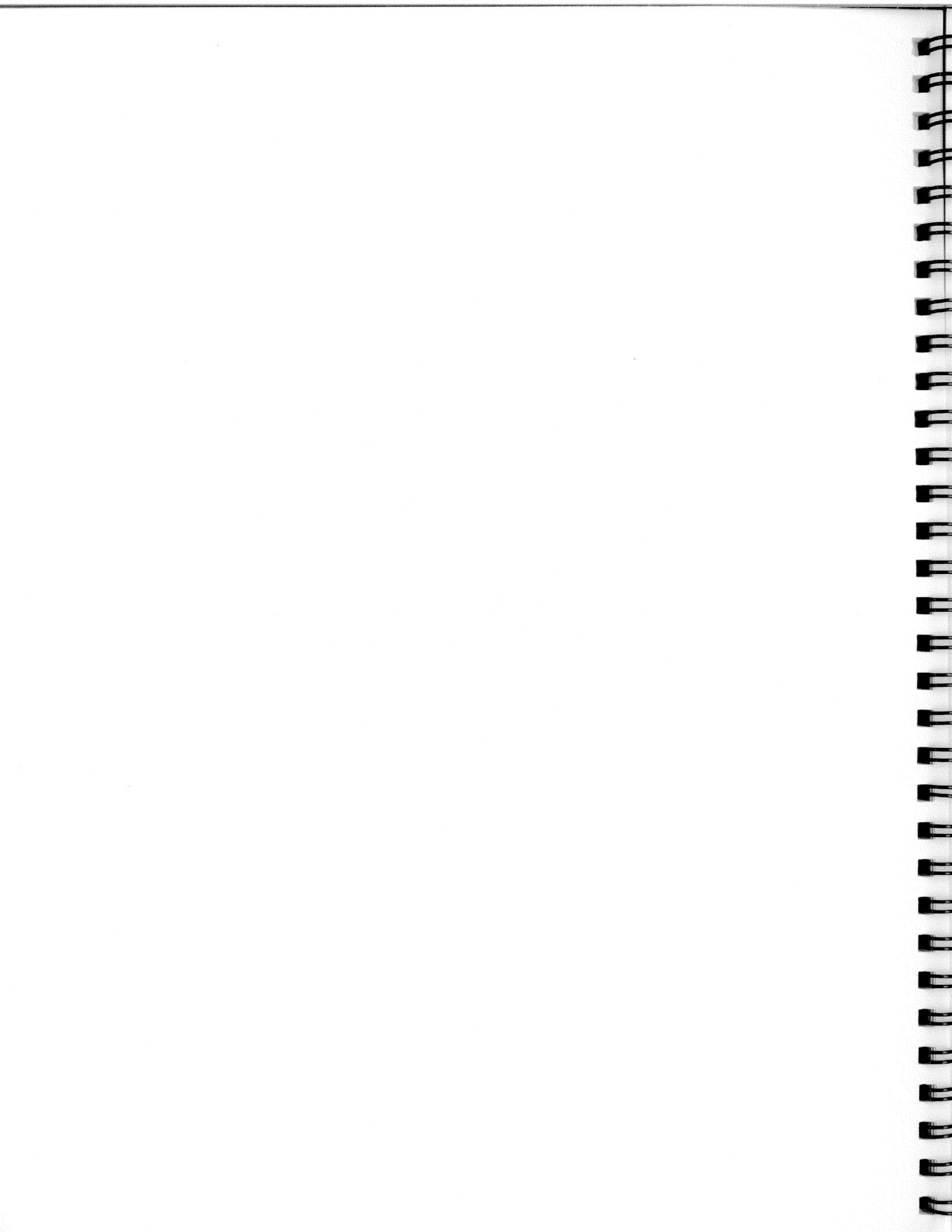

Figure B-1 VT220 FRUs (Exploded View)



APPENDIX C
CABLE INFORMATION

The cable connections for the VT220 video terminal are shown in Figure C-1. The available interface cables are listed in Table C-1 and the modem control selections in Table C-2.

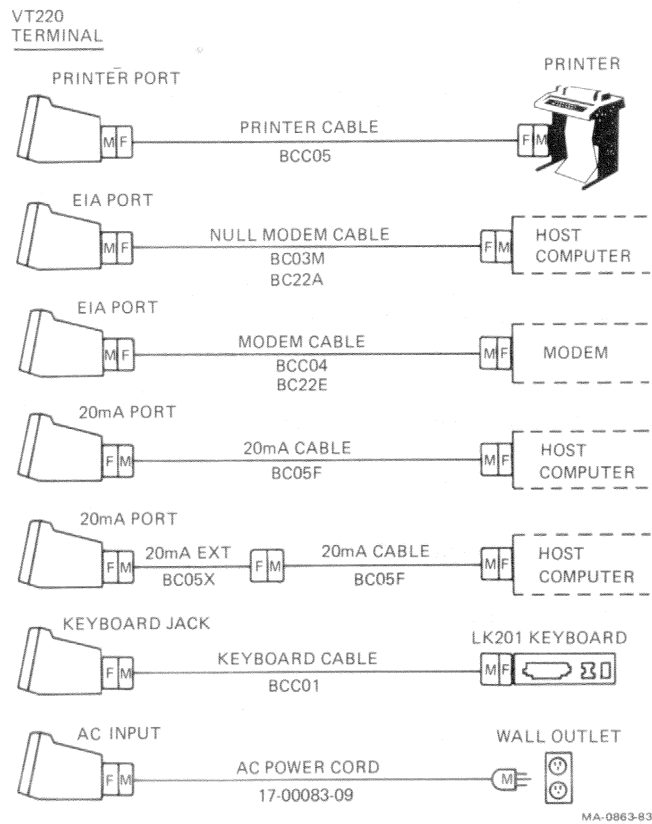

Figure C-1 Cable Summary

Table C-1 Interface Cables

| Cable | Number | Connector | Function |
|----------|-------------|--------------------|--------------------------------------|
| BCC05-10 | 17-00300-00 | 9 pin F RS232 | VT220 and printer |
| BCC05-25 | 17-00300-01 | to 25 pin F RS232 | (printer cable) |
| BC22A-10 | 17-00313-01 | 25 pin F RS232 | Null modem cable, |
| BC22A-25 | 17-00313-02 | to 25 pin F RS232 | VT220 to host |
| BC22A-50 | 17-00313-04 | | |
| BCC04-10 | 17-00289-00 | 25 pin F RS232 | Modem cable, |
| BCC04-25 | 17-00289-01 | to 25 pin M RS232 | VT220 to modem |
| BC22E-10 | 17-00322-01 | 25 pin F RS232 | Modem cable, |
| BC22E-25 | 17-00322-02 | to 25 pin M RS232 | VT220 to modem |
| BC05F-15 | | 8 pin M | 20 mA cable, |
| BC05F-50 | | to M | VT220 to host |
| BC05X-15 | | 8 pin to 8 pin | 20 mA extension, |
| BC05X-50 | | | VT220 to 20 mA cable |
| BCC01-06 | 17-00294-00 | Telephone jack | Keyboard cable, VT220 to keyboard |
| N/A | 17-00083-09 | Output to AC input | AC power cable |

Table C-2 Modem Control Selections

| Selection | Description | Usual Application |
|---------------------------|--|---|
| EIA Data leads only | Full duplex no EIA modem control (data leads only) | Full duplex communication with a null modem (direct) connection to the computer or with a modem that does not use modem control signals. |
| EIA modem control | Full duplex with EIA modem control | Full duplex communication with a modem that uses modem control signals, or with a port on the host computer supporting modem controls. |

APPENDIX D
PHYSICAL FUNCTIONAL DIAGRAM

See Figure D-1 for a physical functional diagram showing the interrelationships among components.

NOTE

All voltage readings are based on a line voltage of 115 Vac. Your readings may differ in accordance with any variations in your line voltage.

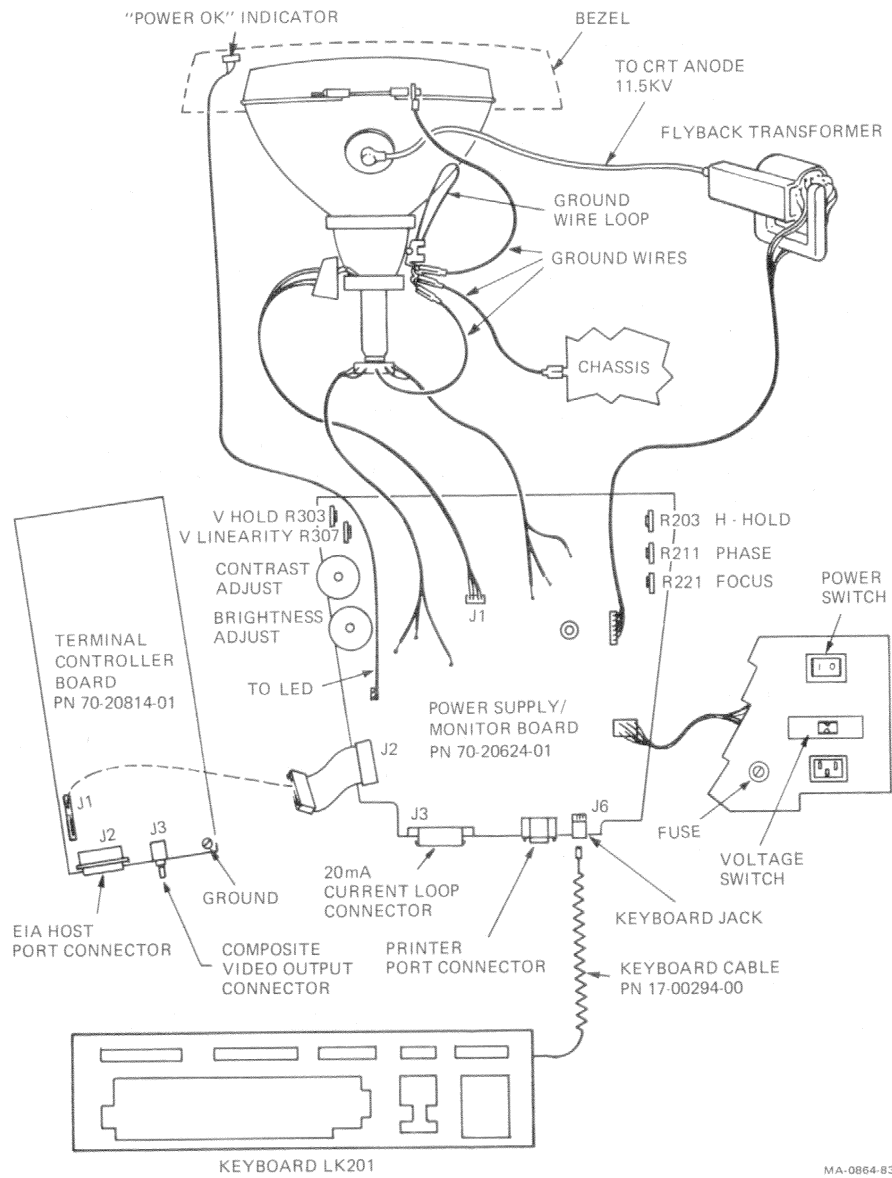

MA-0864-83

Figure D-1 Physical Functional Diagram

POWER SUPPLY/MONITOR BOARD

J1 (CRT Yoke Cable Connector)

| | | |
|-----|---|--------------------|
| Pin | 1 | Vertical (Yellow) |
| | 2 | Horizontal (Red) |
| | 3 | Horizontal (Green) |
| | 4 | Vertical (Brown) |

J2 (Power Supply/Monitor Board to Controller Connector)

| | | |
|-----|----|------------------------|
| Pin | 1 | Test/status |
| | 2 | -20 mA Transmit - |
| | 3 | +20 mA Transmit + |
| | 4 | Keyboard Transmit Data |
| | 5 | Printer Transmit Data |
| | 6 | Printer Data Set Ready |
| | 7 | +5 Vdc |
| | 8 | +5 Vdc |
| | 9 | Ground |
| | 10 | Ground |
| | 11 | Video |
| | 12 | Horizontal |
| | 13 | Video ground |
| | 14 | Video ground |
| | 15 | Vertical |
| | 16 | Ground |
| | 17 | Ground |
| | 18 | +5 Vdc |
| | 19 | +5 Vdc |
| | 20 | +12 Vdc |
| | 21 | -12 Vdc |
| | 22 | + Printer Receive Data |
| | 23 | Keyboard Receive Data |
| | 24 | 20 mA Receive + |
| | 25 | 20 mA Receive - |
| | 26 | Prod Reset |

J4 (Printer Port Connector)

| | | |
|-----|---|---------------------|
| Pin | 1 | Protected Ground |
| | 2 | PTR TDATA |
| | 3 | PTR RDATA |
| | 4 | Request to Send |
| | 5 | Data Terminal Ready |
| | 6 | PTR Data Set Ready |
| | 7 | Signal Ground |
| | 8 | Not Used |
| | 9 | Not Used |

J501 (Secondary Cable Connector)

| | | |
|-----|---|-----------|
| Pin | 1 | Secondary |
| | 2 | Secondary |
| | 3 | Secondary |

J6 (Keyboard Connector)
Pin 1 Keyboard Receive
2 Ground
3 +12 Vdc
4 +5 Transmit

TERMINAL CONTROLLER BOARD

J2 (EIA Connector)
Pin 1 N.C.
2 Transmitted Data
3 Received Data
4 Request to Send
5 Clear to Send
6 Data Set Ready
7 Signal Ground
8 Received Line Signal Detector
9 N.C.
10 N.C.
11 N.C.
12 Speed Indicator (FDX)
13 N.C.
14 12 Vdc
15 N.C.
16 N.C.
17 N.C.
18 N.C.
19 N.C.
20 Data Terminal Ready
21 N.C.
22 N.C.
23 Speed Select
24 N.C.
25 N.C.

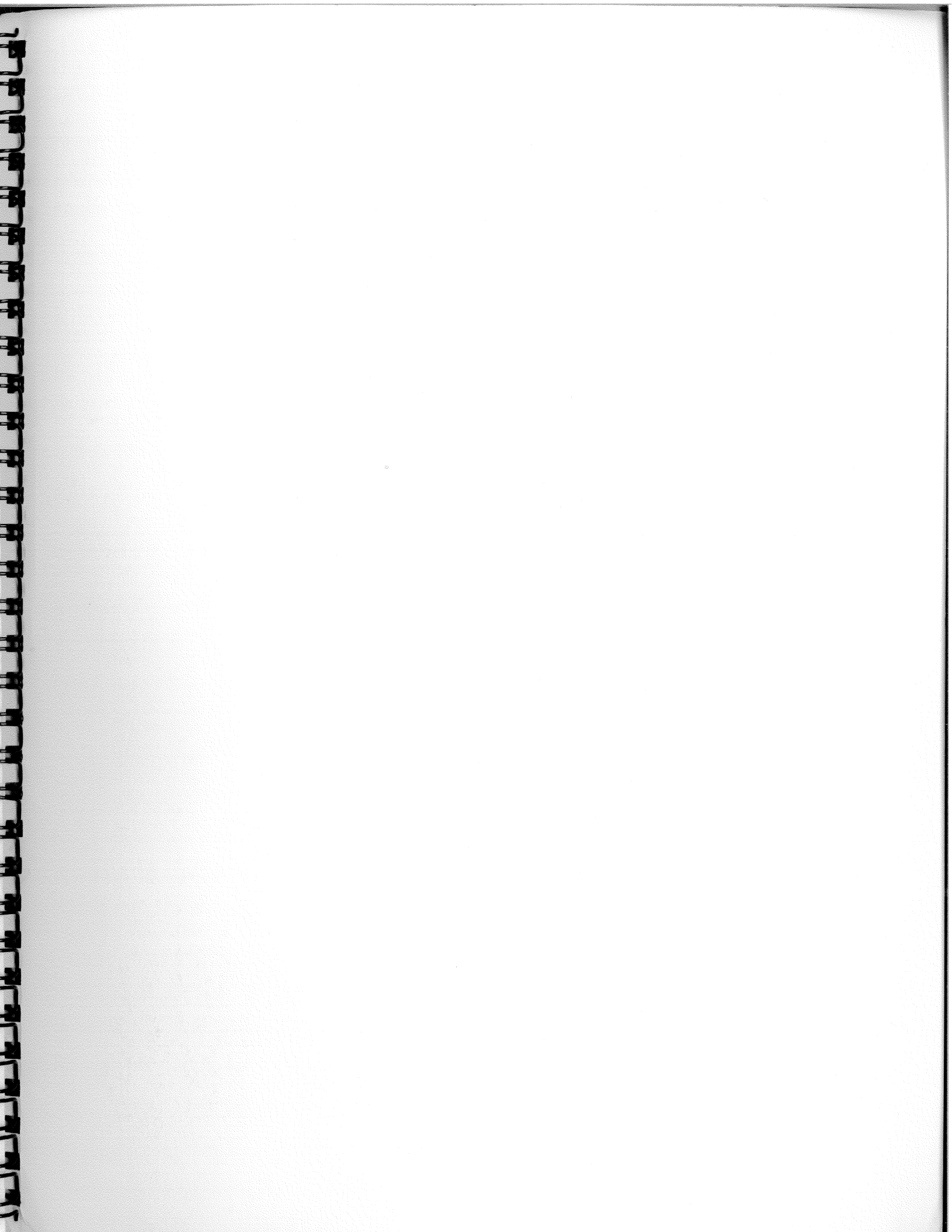

Printed in U.S.A.

EK-VT220-PS-001