

# KDA50 User Guide



# KDA50 User Guide

Prepared by Educational Services  
of  
Digital Equipment Corporation

---

November 1987

Digital Equipment Corporation makes no representation that use of its products with those of other manufacturers will not infringe existing or future patent rights. The descriptions contained herein do not imply the granting of a license to make, use, or sell equipment or software as described in this manual.

Digital Equipment Corporation assumes no responsibility or liability for the proper performance of other manufacturers' products used with its products.

Digital Equipment Corporation believes that information in this publication is accurate as of its publication date. Such information is subject to change without notice. Digital Equipment Corporation is not responsible for any inadvertent errors.

**Class A Computing Devices:**

**NOTICE:** This equipment generates, uses, and may emit radio frequency energy. It has been tested and found to comply with the limits for a Class A computing device pursuant to Subpart J of Part 15 of FCC rules for operation in a commercial environment. This equipment, when operated in a residential area, may cause interference to radio/TV communications. In such event the user (owner), at his own expense, may be required to take corrective measures.

---

Copyright © 1987 by Digital Equipment Corporation

All Rights Reserved.  
Printed in U.S.A.

---

The postpaid READER'S COMMENTS form requests the user's critical evaluation to assist in preparing future documentation.

The following are trademarks of Digital Equipment Corporation:

VAX	DECnet	UDA50
DIGITAL	HSC	SA482
RA81	KDA50-Q	RA80
TA78-81	RA60	TU78-81
UNIBUS	VMS	RA70
RC25	KDB50	
SA70	SA600	





# CONTENTS

<b>Preface</b> .....	vi
----------------------	----

## CHAPTER 1 GENERAL INFORMATION

1.1	OVERVIEW .....	1-1
1.2	DIGITAL STORAGE ARCHITECTURE .....	1-1
1.3	MASS STORAGE CONTROL PROTOCOL .....	1-1
1.4	KDA50 MODULES .....	1-3
1.4.1	SDI Module .....	1-3
1.4.2	Processor Module .....	1-3
1.5	KDA50 FUNCTIONAL MICROCODE .....	1-3
1.5.1	Q-bus Control Stream .....	1-3
1.5.2	Drive Control Stream .....	1-4
1.6	KDA50 SPECIFICATIONS .....	1-4
1.7	DIGITAL CUSTOMER SERVICE CONTRACT OPTIONS .....	1-5
1.7.1	Hardware Services .....	1-5
1.7.2	Software Services .....	1-6
1.8	RELATED DOCUMENTATION .....	1-6

## CHAPTER 2 INSTALLATION

2.1	INTRODUCTION .....	2-1
2.2	KDA50 INSTALLATION OVERVIEW .....	2-2
2.3	MODULE PREPARATION AND INSTALLATION .....	2-3
2.3.1	I/O Page Address Switches and Jumpers .....	2-3
2.3.2	Bus Grant Jumpers .....	2-4
2.3.3	Q-bus Tuning .....	2-8
2.3.3.1	Q-bus Device Positions .....	2-8
2.3.3.2	KDA50 Burst Rate Parameter .....	2-9
2.3.4	M7164 Intermodule Cable Installation .....	2-10
2.3.5	M7164 Module Installation .....	2-10
2.3.6	M7165 SDI Cable Installation and Initial M7165 Insertion .....	2-11
2.3.7	M7165 Intermodule Cable Installation .....	2-11
2.3.8	Final M7165 Installation .....	2-11
2.4	INSTALLATION PACKAGES .....	2-12
2.4.1	KDA50-QA—Standard Installation Package .....	2-12
2.4.2	I/O Bulkhead Installation .....	2-12
2.4.2.1	Internal SDI Cables Installation .....	2-14
2.4.2.2	External SDI Cables Installation .....	2-15

**CONTENTS**

2.4.3 KDA50-QB—Alternate Installation Package . . . . . 2-16  
2.4.3.3 Mounting the Alternate Bulkhead Assembly . . . . . 2-17  
2.4.3.4 Alternate Internal SDI Cable Installation . . . . . 2-19  
2.4.3.5 Alternate External SDI Cable Installation . . . . . 2-19

**CHAPTER 3 FIELD ACCEPTANCE TEST PROCEDURE**

3.1 OVERVIEW . . . . . 3-1  
3.2 DIAGNOSTICS . . . . . 3-1  
3.2.1 Drive-Resident Diagnostics . . . . . 3-3  
3.2.2 PDP-11 Subsystem Diagnostics . . . . . 3-3  
3.2.2.1 Sample CZUDH Prompts . . . . . 3-4  
3.2.2.2 Sample CZUDI Prompts . . . . . 3-5  
3.2.2.3 Sample CZUDJ Prompts . . . . . 3-5  
3.2.2.4 Sample CZUDM Prompts . . . . . 3-6  
3.2.3 MicroVAX Subsystem Diagnostics . . . . . 3-6  
3.2.4 Running MDM . . . . . 3-7  
3.2.4.1 Choice 1—Test the System . . . . . 3-8  
3.2.4.2 Choice 2—Display System Configuration and Devices . . . . . 3-8  
3.2.4.3 Choice 3—Display the Utilities Menu . . . . . 3-9  
3.2.4.4 Choice 4—Display the Service Menu . . . . . 3-9  
3.2.4.5 Choice 5—Exit MicroVAX Maintenance System . . . . . 3-10  
3.3 SYSTEM AND SOFTWARE CONSIDERATIONS . . . . . 3-10  
3.3.1 System Clock or Timer . . . . . 3-10  
3.3.2 Error Logs . . . . . 3-11  
3.3.3 Drive Numbering . . . . . 3-11

**CHAPTER 4 KDA50 PROGRAMMER INFORMATION**

4.1 KDA50 SPECIFIC PROGRAMMING INFORMATION . . . . . 4-1

**FIGURES**

1-1 KDA50 Disk Subsystem Configuration . . . . . 1-2  
2-1 KDA50 Illustrated Parts Breakdown . . . . . 2-2  
2-2 M7164 Jumpers and Bus Address Switches . . . . . 2-4  
2-3 KDA50 Switch Setting for Octal Address 172150 (F468 Hex) . . . . . 2-5  
2-4 Address Selector Switch Operation . . . . . 2-6  
2-5 M7165 (C- and D-Etch) Jumper Locations . . . . . 2-7  
2-6 M7165 (E-Etch) Jumper Locations . . . . . 2-8  
2-7 KDA50 Intermodule Flat Ribbon Cables . . . . . 2-10  
2-8 M7165 SDI Cable Assembly Installation . . . . . 2-11  
2-9 BA11 2 x 3 Adapter Plate Installation . . . . . 2-13  
2-10 Bulkhead to I/O Panel Attachment . . . . . 2-14  
2-11 Internal SDI Cable Installation . . . . . 2-15  
2-12 External SDI Cable Installation . . . . . 2-16  
2-13 Alternate Bulkhead Assembly . . . . . 2-18



## PREFACE

This guide describes how to install, checkout, and operate the KDA50 controller. It is intended for the equipment user and includes detailed equipment specifications in the first chapter.

This guide does not cover maintenance and servicing. Information on these subjects is provided separately in the *KDA50 Service Manual*. For further information, refer to the Related Documentation section included in Chapter 1.

# CHAPTER 1

## GENERAL INFORMATION

### 1.1 OVERVIEW

The KDA50 is an intelligent disk controller that can interface as many as four 16-bit SDI disk drives with any CPU operating on a Q-bus. The exact number of drives supported depends on the operating system and system configuration. For further information, refer to the related Software Product Description (SPD).

The KDA50 contains two quad-height modules: the Standard Disk Interconnect (SDI) module and the processor module. This controller uses a radial bus configuration instead of the conventional daisy-chain (serial) bus method. Such a radial bus configuration has separate I/O cables attached between each drive and the controller. Figure 1-1 shows the KDA50 subsystem configuration.

### 1.2 DIGITAL STORAGE ARCHITECTURE

The KDA50, a member of the Digital Storage Architecture (DSA) family, implements the Standard Disk Interconnect (SDI). DSA defines the functions to be performed by the host computer, controller, and drive and specifies how they interact to manage mass storage. SDI is the Digital Storage Architecture standard for connecting large system disk drives and controllers. Some of the characteristics of DSA are as follows:

- The controller, rather than the host, manages most input/output (I/O) operations.
- The host views the disk subsystem as one contiguous string of sectors known as logical blocks. (A logical block contains 512 bytes of information.)
- The disk geometry, (cylinder, track, sector, etc.), is unknown to the host.
- The host and subsystem exchange messages using Mass Storage Control Protocol (MSCP).

### 1.3 MASS STORAGE CONTROL PROTOCOL

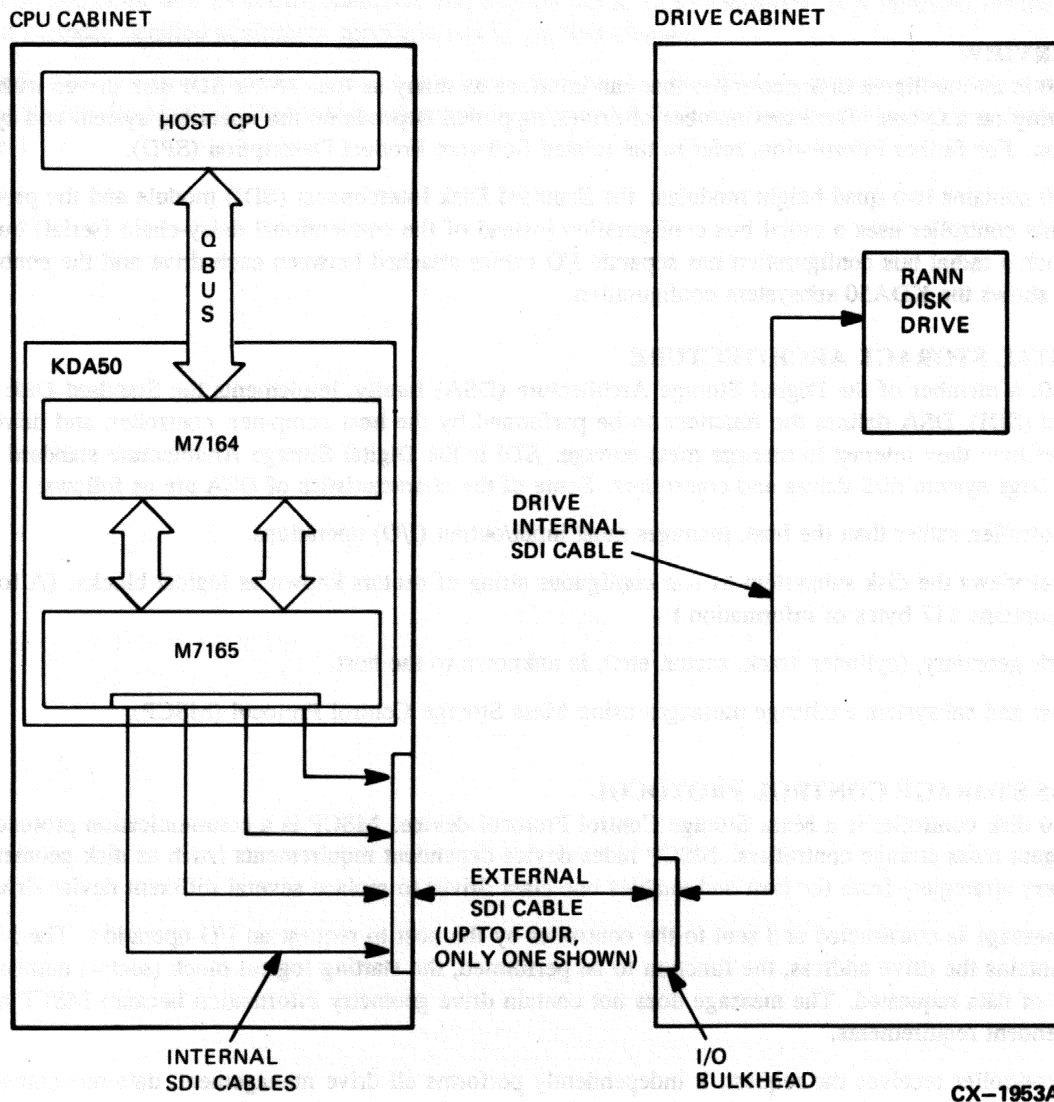
The KDA50 disk controller is a Mass Storage Control Protocol device. MSCP is a communication protocol used with intelligent mass storage controllers. MSCP hides device-dependent requirements (such as disk geometry and error recovery strategies) from the host and enables one class driver to replace several different device drivers.

A MSCP message is constructed and sent to the controller by the host to request an I/O operation. The MSCP message contains the drive address, the function to be performed, the starting logical block (sector) number, and the amount of data requested. The message does not contain drive geometry information because MSCP masks device-dependent requirements.

When the controller receives the request, it independently performs all drive management, data movement, and any necessary error recovery. For example, in the recovery technique called revectoring, the KDA50 accesses a replacement sector instead of the original sector in error. This original sector is replaced by means of a cooperative process between the host software and the KDA50. Upon completion of the replacement, the subsystem sends status information to the host with an MSCP response message. This flow differs from conventional subsystems where host computer resources are used to control the drive.

**GENERAL INFORMATION**

**Figure 1-1 KDA50 Disk Subsystem Configuration**



## 1.4 KDA50 MODULES

The following paragraphs describe the hardware on the SDI and processor modules.

### 1.4.1 SDI Module

The Standard Disk Interface (SDI) module (M7165) is the communication interface between the KDA50 processor module and the disk drives. Some of the circuitry and functions of the SDI module follow:

- Contains a 32K-byte high-speed buffer used during data transfers. The buffer permits controller-to-drive transfers at a higher rate than controller-to-host transfers. This improves performance by minimizing missed disk revolutions due to a full buffer condition.
- Converts the KDA50 buffer format (parallel) to SDI format (serial) and SDI format (serial) to KDA50 buffer format (parallel).
- Generates the real-time Error Correction Code (ECC). ECC has a correction capability of eight 10-bit error bursts per block (sector).
- Implements the real-time and electrical interface to the SDI, including error detection on the SDI and RAM.

### 1.4.2 Processor Module

The processor module (M7164) is the control portion of the KDA50. Some of the circuitry and functions of the processor module are:

- Performs all KDA50 interaction with the Q-bus by means of two registers: the initializing and polling (IP) register and the status/address (SA) register. A switch pack is used to set the I/O page register address (CSR).
- Reports microcode-detected errors through four LEDs on the processor module and four LEDs on the SDI module. The reported error code indicates the defective module.

Also located on the processor module is a dual microprocessor, containing two 12-bit microprogram sequencers that share a common 16-bit ALU. This microprocessor is capable of simultaneously executing two independent, interleaved microprograms from Read Only Memory. One of the sequencers controls the KDA50 to host interaction, and the other controls the KDA50 to disk drive interaction. For greater efficiency, one sequencer fetches an instruction while the other executes an instruction.

## 1.5 KDA50 FUNCTIONAL MICROCODE

The functional microcode is divided into two functional flows or streams: the Q-bus control stream which manages the controller-to-host interface and the drive control stream which manages the controller-to-disk drive interface.

### 1.5.1 Q-bus Control Stream

Some of the functions of the Q-bus control stream are:

- Branching to the appropriate handling routine in the microcode when the host wants to send a command to the KDA50 or the KDA50 has a response to send to the host
- Exchanging information packets with the host in memory
- Validating each host packet
- Analyzing the drive packets and performing the following functions:
  - Decoding the logical block number (LBN) to cylinder, group, track, and sector information
  - Optimizing seek selection from the outstanding commands
  - Allocating data buffer space
  - Computing and storing parameters for each sector transfer
  - Performing packet error detection



## GENERAL INFORMATION

- Performing memory mapping for mapped requests
- Transferring data between the host and internal memory (including automatic support for block mode memories)
- Performing Error Correction Code (ECC)
- Polling the command queue at each command completion
- Performing initialization
- Initiating drive control stream packet executions
- Constructing the KDA50 response packets for transmission to the host

### 1.5.2 Drive Control Stream

Some of the functions the drive control stream performs are:

- Monitoring the ATTENTION signal from the drives. When drive attention has been detected, the drive control stream gets the drive status, compares it with the previous status, and takes appropriate action.
- Constructing and sending packets to the disk drives. The packets may be the result of a host request (read, write, replace, etc.) or in response to a drive attention condition.
- Receiving and validating packets from the drives
- Monitoring the drive status flags from the Q-bus control stream. The drive status flags are used for communication between the Q-bus control stream and the drive control stream.
- Performing the following tasks as required by the drive status flags:
  - Initiating read, write, seek, and head select packets to the drive
  - Reading and verifying the block (sector) header
  - Performing data transfers between the internal RAM and the disk drive
  - Updating drive status and buffer-use flags
  - Performing data error analysis and recovery

## 1.6 KDA50 SPECIFICATIONS

The KDA50 disk controller specifications are described in Table 1-1.

Table 1-1 KDA50 Specifications

Characteristics	Specifications
Physical components	KDA50 processor module (M7164) KDA50 SDI module (M7165) 50-pin flat cable assembly 40-pin flat cable assembly SDI cable assembly I/O bulkhead assemblies
Power consumption	67.9 watts maximum, steady state
Heat dissipation	Approximately 238.6 BTU/hour



Table 1-1 (Cont.) KDA50 Specifications

Characteristics	Specifications
Electrical voltage and current requirements	+5V +12V
M7164	6.93A 0.00A
M7165	6.57A 0.03A
Totals	13.50A 0.03A
Q-bus loading	3.0 0.5 standard loads (total)
Operating temperature range	10 to 40°C (50 to 104°F), with a temperature gradient of 20°C/hour (36°F/hour)
Operating relative humidity range	10 to 90%, with a wet bulb temperature of 28°C (82°F) and a minimum dew point of 2°C (36°F)
Operating altitude range	Sea level to 2400 meters (8000 ft). Adjust the maximum allowable operating temperature by 1.8°C/1000 meters (1°F/1000 feet) for operation above sea level.
Mounting restrictions	Mounts in 2 quad-height Q-bus SPC slots in the following mounting boxes: dual BA23 (rack-mounted with H3490 I/O distribution panel) and BA123. To install the KDA50 in BA123s shipped before April 30, 1987, use the BA123 Compliant Kit (BA123-UC) to meet FCC regulations. BA123 models shipped after April 30, 1987, support the KDA50 without the compliant kit.
Bulkhead requirements	Two 2 x 3 standard cutouts for H3490 or BA123, two 6.35 x 8.10 cm (2.50 x 3.19 in.) cutouts, and two 2 x 3 adapter plates (supplied) for BA11-S or -N.

## 1.7 DIGITAL CUSTOMER SERVICE CONTRACT OPTIONS

You can upgrade your CPU system efficiently and maintain optimum performance by taking advantage of one of the service options listed below.

### 1.7.1 Hardware Services

DIGITAL provides a full range of hardware services for the KDA50 and all of the associated DIGITAL products in the host system.

Installation of all DIGITAL products must be performed by a qualified DIGITAL service representative.

Installation includes:

- Preinstallation evaluation to ensure a suitable site environment, including power, temperature, and humidity.
- Physical connection of equipment and verification of full system functionality.

Ongoing services for add-ons and upgrades to the system should also be performed by qualified DIGITAL representatives. Our ongoing maintenance service provides a comprehensive range of both services and times of coverage. After the system upgrade, or add-on has been installed, select the most appropriate service coverage for your application.

## GENERAL INFORMATION

Ongoing add-on and upgrade services are:

- **DEC service**—A comprehensive on-site service providing a program of preventive maintenance, committed response times, continuous effort until the problem is solved, installation of the latest engineering changes, and automatic escalation for complex problems.
- **Basic Service**—An economical full-service coverage providing priority status second only to DECservice calls, as well as the preventive maintenance on-site services listed under DECservice.
- **Per Call Service** is recommended only for the less critical for applications but provides full service for DIGITAL products performed by qualified DIGITAL representatives. This service is charged on a time-and-materials basis.
- **Carry-in or DECmailer Services** are designed to accommodate the self-maintenance customer. Such customers may only require guaranteed DIGITAL parts for repair of their systems.

### 1.7.2 Software Services

If the need arises to analyze or upgrade a current system or to develop or implement software, DIGITAL offers the following services.

1. **Computer Performance Service**—Helps develop growth plans by identifying add-on or upgrade options before problems begin.
2. **System Start-up Service Package**—Provides fixed-cost training for customer personnel, as well as one year of support services.
3. **Consulting Service**—Provides software programming or project manager expertise on a choice of resident, per-call, or fixed-price basis.

For more information, call the local DIGITAL field service office.

### 1.8 RELATED DOCUMENTATION

DIGITAL customers may also order the related documentation shown in the following list.

**External DIGITAL Customers:** Additional copies of this user guide, as well as the *KDA50 Service Manual* can be ordered directly from Digital Equipment Corporation, P.O. Box CS2008, Nashua, New Hampshire 03061, or by calling toll-free: 800-258-1710.

**Internal DIGITAL Customers:** The service manual and additional copies of this user guide can be ordered directly from Publishing and Circulation Services, 10 Forbes Road, Northboro, Massachusetts 01532 (RCS Code: NR12, Mail Code: NRO3/W3).

Outside the United States, consult local DIGITAL offices.

## CHAPTER 2 INSTALLATION

### 2.1 INTRODUCTION

The KDA50 is a two-module disk controller which can be installed in a variety of CPU packages. Although these CPU packages are different, the KDA50 installation procedure is similar. Table 2-1 lists these packages and the KDA50 assembly used with them.

Table 2-1 KDA50 Assemblies

CPU Package	KDA50 Assembly
BA23 with H3490, <sup>1</sup> BA123, or BA11-S or -N (5 1/4" box) <sup>2</sup>	KDA50-QA
Alternate installation package	KDA50-QB
BA213 installation packages	KDA50-QC

<sup>1</sup>If necessary also order BA23 expansion rackmount package when installing this assembly. This package permits the optional addition of a second rack-mounted BA23 with a Q-bus expansion kit, and includes the BA23 expansion cabinet, the BA23 rackmount kit, and the H3490 expansion I/O bulkhead.

<sup>2</sup>The BA11 box uses an I/O panel with cutouts intended for MASSBUS cable use. These cutouts must be adapted to 2 x 3 cutout size using the supplied adapter plates.

#### NOTE

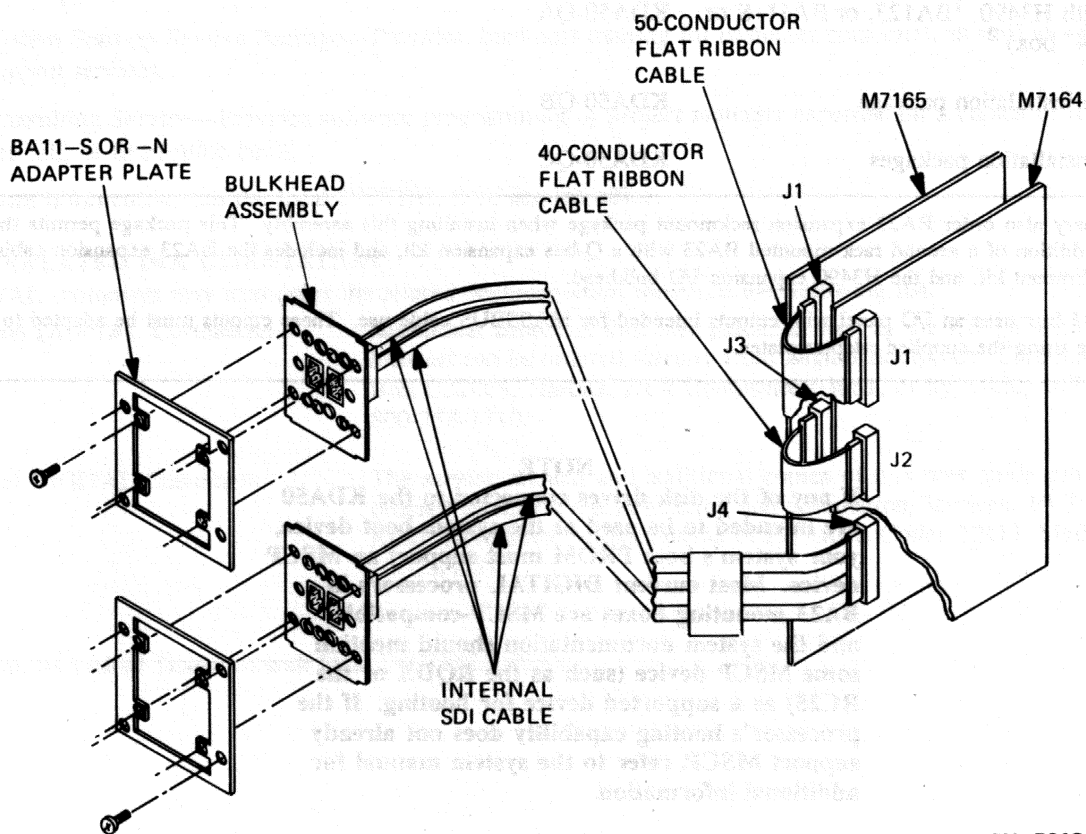
If any of the disk drives connected to the KDA50 are intended to be used as the system boot device, your system's boot PROM must support an MSCP device. Most current DIGITAL processors in BA23 mounting boxes are MSCP-compatible, and the system documentation should mention some MSCP device (such as the RQDX or the RC25) as a supported device for booting. If the processor's booting capability does not already support MSCP, refer to the system manual for additional information.

## INSTALLATION

### 2.2 KDA50 INSTALLATION OVERVIEW

The installation procedure for the KDA50 disk controller requires the insertion of two quad-high modules into a Q-bus backplane. These two modules are inserted in adjacent slots so that intermodule cables can be connected between them. One or two I/O bulkheads (depending on the number of drives to be attached) must be installed in the cutouts provided at the rear of the CPU cabinet unless the alternate installation procedure, described in Section 2.4.3, is used. The I/O bulkheads (bulkhead assemblies) are installed with an internal SDI cable connecting them to the modules. The disk drives are also connected to the I/O bulkhead. Figure 2-1 shows an illustrated parts breakdown of the KDA50 assembly.

Figure 2-1 KDA50 Illustrated Parts Breakdown



CX-501C

The KDA50 modules may be installed horizontally or vertically, depending upon the CPU package. If the CPU package requires the horizontal insertion of modules, the following vertical orientation checklist may still be used by considering module M7164 as the top module. Parentheses at the end of the sentences indicate procedure locations.

1. Connect the 40-conductor and 50-conductor intermodule cables to module M7164 (J2) and (J1) respectively (Section 2.3.4).

**NOTE**

**Before continuing, ensure power is turned off.**

2. Insert module M7164 into the first of two vacant backplane slots and engage the handle retainer latches. Leave the 50-conductor cable on top of the handle retainer latch. (Section 2.3.5).
3. Insert and clamp the internal SDI cable to module M7165 (J4). Slide M7165 halfway into the second backplane slot (Section 2.3.6).
4. Connect both the 40-conductor and 50-conductor intermodule cables to module M7165 (J3 and J1) (Section 2.3.7).
5. Press M7165 into the backplane, engaging the handle retainer latches (Section 2.3.8).
6. If the standard installation package is used, install the I/O bulkhead connector assembly, route the internal SDI cable ends to the bulkhead location, and connect the external SDI cables (from SDI disk drives) to the bulkhead assembly (Section 2.4).
7. If the alternate installation package is used, mount the alternate bulkhead assembly, connect the internal SDI cable ends to the bulkhead assembly, and connect the external SDI cables (Section 2.4.3).
8. Perform the field acceptance test procedure (Chapter 3).

If necessary, the position of the KDA50 modules can be reversed. Ensure the top or left module initially installed has the 40-conductor and 50-conductor flat ribbon cables attached. Also, ensure the 50-conductor flat ribbon cable connected to the second module is not crimped by the module handle retainer latches.

### 2.3 MODULE PREPARATION AND INSTALLATION

The following paragraphs describe the KDA50 modules, I/O bulkhead, and cables.

#### 2.3.1 I/O Page Address Switches and Jumpers

The KDA50 disk controller contains two registers visible in the I/O page. These registers are the initializing and polling (IP) register and the status and address (SA) register. The SA register acts as the KDA50 Control and Status Register and is assigned the default octal Q-bus address of 172150 (F468 hex). The SA register address is the IP address plus two.

The address selector switches and a jumper (W1) are used to set the Q-bus address for the IP register. The location of these switches and the jumper on KDA50 module M7164 is shown in Figure 2-2. Set the address switches and W1 to the positions shown in Figure 2-3 and Figure 2-4 to select the default octal Q-bus address of 172150 (F468 hex).

**NOTE**

**Because other DSA controllers (such as RQDXn, RC25, RRD50) are shipped with the same default CSR address as the KDA50, the KDA50 address switches and jumpers should be set for a floating address (W1 removed) when another DSA controller is present in the system. Possible default values in the floating address space are Octal 160334 (E0DC hex), followed by Octal 160340 (E0E0 hex).**

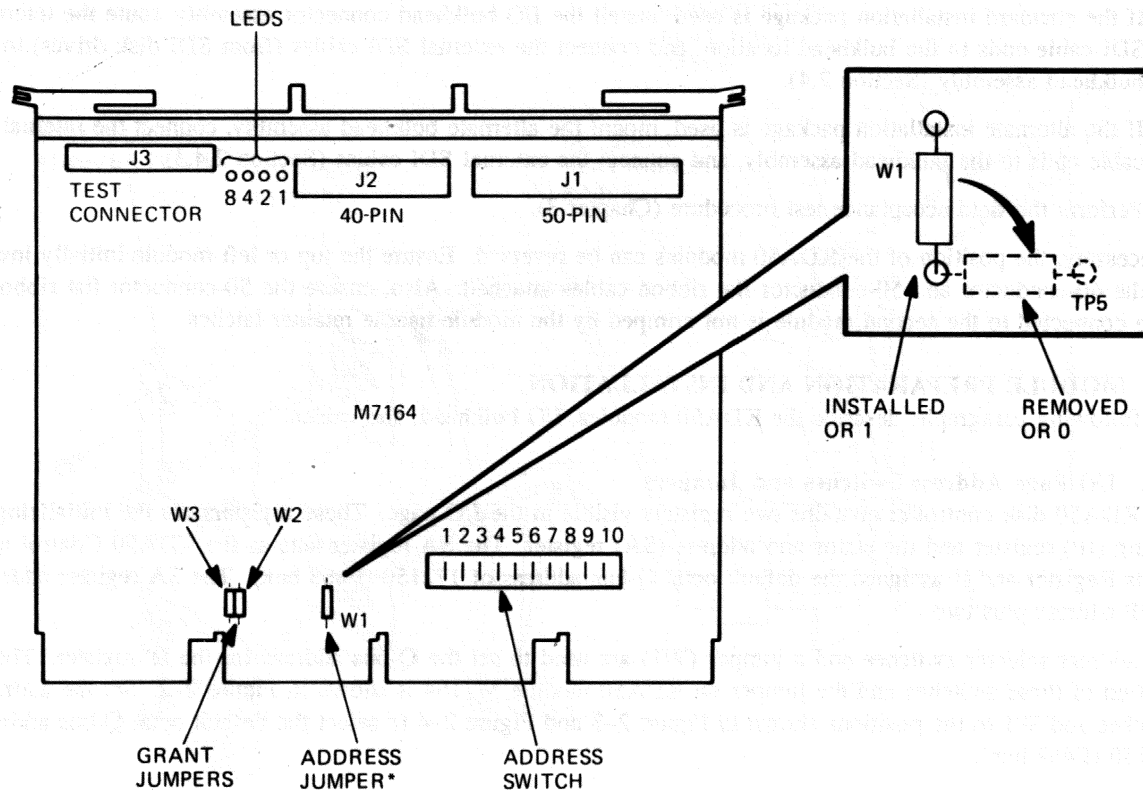
## INSTALLATION

However, if other devices in the system are already assigned to these addresses, an alternate address must be chosen. Refer to system and software documentation for address assignment.

### 2.3.2 Bus Grant Jumpers

Two jumpers on each KDA50 module (W2 and W3) are used to provide bus-grant compatibility between the KDA50 and the Q22/CD backplane, as well as between the KDA50 and the Q22/Q22 backplane. For the Q22/CD backplane type, W2 and W3 must be removed from both modules. Conversely, for the Q22/Q22 backplane type, W2 and W3 must be present on both modules. This is the default KDA50 configuration. Figure 2-2 shows the location of these jumpers on M7164. Figure 2-5 and Figure 2-6 show the location of these jumpers on M7165.

Figure 2-2 M7164 Jumpers and Bus Address Switches



\* NOTE: B REV ETCH - BLACK STRIPE  
C REV ETCH - BLUE JUMPER

CX-502C

Figure 2-3 KDA50 Switch Setting for Octal Address 172150 (F468 Hex)

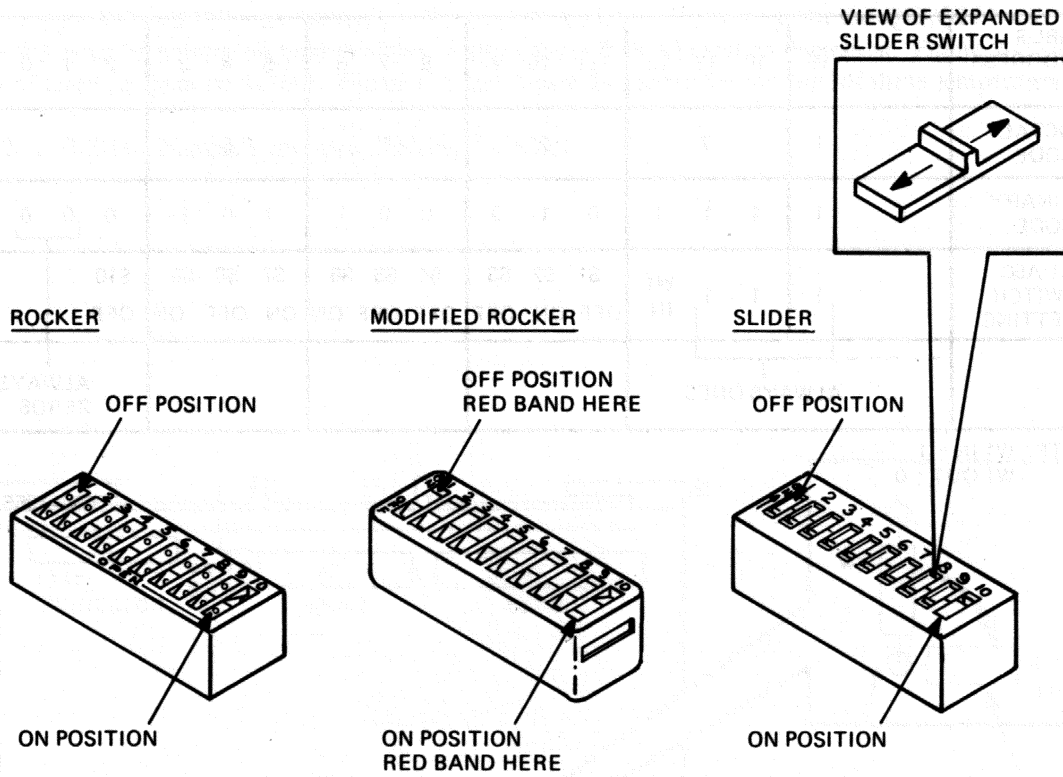
QBUS ADDRESS BITS	15	14 13 12	11 10 9	8 7 6	5 4 3	2 1 0
OCTAL CODE	1	7	2	1	5	0
BINARY CODE	1	1 1 1	0 1 0	0 0 1	1 0 1	0 0 0
KDA50 SWITCH SETTING	1	1 1 1 W1 IN	S1 S2 S3 OFF ON OFF	S4 S5 S6 OFF OFF ON	S7 S8 S9 ON OFF ON	S10 OFF
	ALWAYS ONES					ALWAYS ZEROS

NOTE: W1 IN = 1  
W1 OUT = 0

CX-1955A

# INSTALLATION

**Figure 2-4 Address Selector Switch Operation**

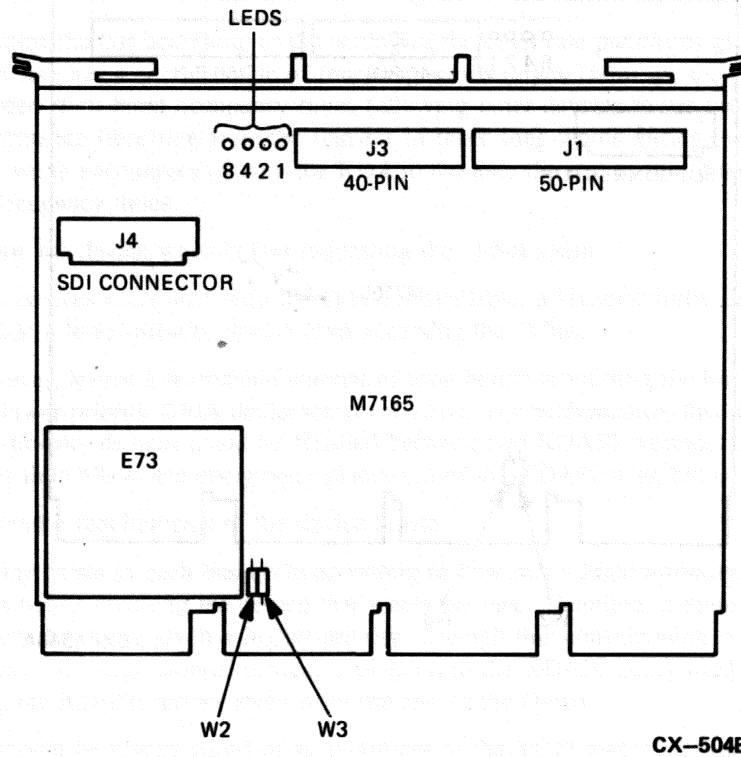


**NOTE:** IN EACH ILLUSTRATION, SWITCHES 1 THROUGH 9 ARE SHOWN IN THE OFF POSITION, AND SWITCH 10 IS SHOWN IN THE ON POSITION.

CX-503A

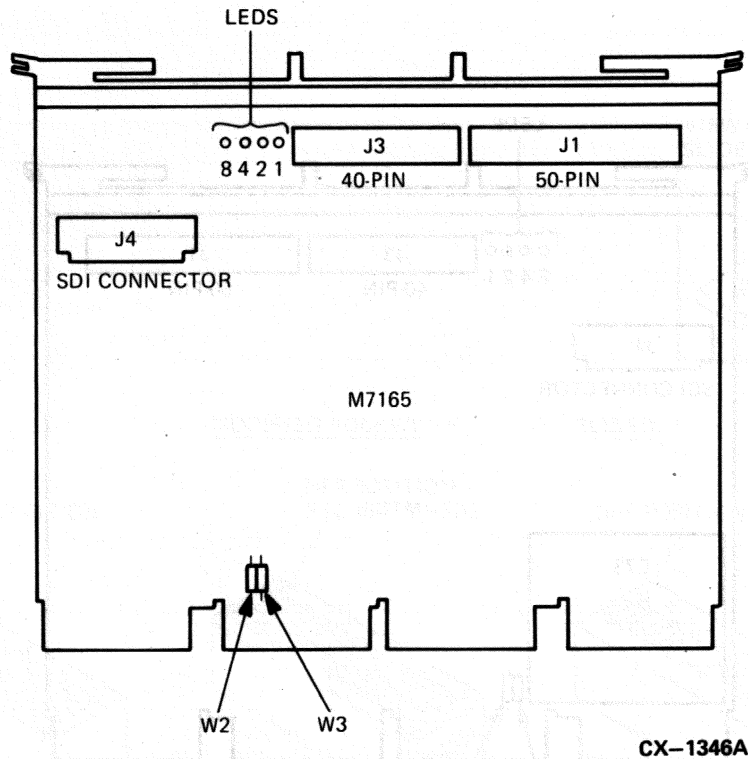


Figure 2-5 M7165 (C- and D-Etch) Jumper Locations



## INSTALLATION

Figure 2-6 M7165 (E-Etch) Jumper Locations



In earlier disk products, a vector address was also physically selectable. This is not true with the KDA50 disk controller. A typical vector address of 154 (octal) is supplied to the KDA50 by the software and varies with different system configurations.

### 2.3.3 Q-bus Tuning

Tuning the Q-bus remedies data-late or reduced performance conditions. The tuning process involves changing the relative positions of the Direct Memory Access (DMA) devices on the bus, or making use of other product features. The DMA device electrically nearest the host processor has the highest priority; the device farthest from the host processor has the lowest priority.

#### 2.3.3.1 Q-bus Device Positions

Non-DMA interfaces along a Q-bus are placed nearest the host processor because they do not significantly affect the performance level of DMA devices.

The proper positioning of DMA devices on the Q-bus involves several considerations:

1. The instantaneous bandwidth requirements of the device or interface

Typically, a device with a high raw bandwidth requires a high priority. However, this high priority requirement may be reduced if the device has sufficient internal buffering to reduce its actual bandwidth requirements. Devices with little buffering may, on the other hand, require the actual bandwidth match or exceed the effective bandwidth for the device.

The KDA50, although it interfaces with some very fast disk devices, is well-buffered internally (which results in a relatively low instantaneous bandwidth requirement). It operates dependably at the very end of the Q-bus (lowest priority). The KDA50 will also wait very long periods of time to gain bus access, and proceed from this waiting period without error.

2. The amount of time the device occupies the Q-bus during each bus access

Devices that hold the Q-bus for longer periods of time are placed at a lower priority to reduce the time that a higher-priority device must wait to gain access to the Q-bus.

The KDA50 occupies the bus according to the setting of the burst rate parameter given to it by the operating system. The burst rate has a default value of four long-words (eight 16-bit words). This provides the best compromise between short burst occupancy times (allowing other devices to use the bus when needed) and high system performance (resulting from the transfer of more long-words during every bus acquisition). Thus, this default value encourages placing the KDA50 towards the end of the Q-bus, but ahead of devices with longer bus occupancy times.

3. The amount of time the device waits before requesting the Q-bus again

Because all DMA devices must wait until the Q-bus is available, a higher-priority device that requests rapid access may preclude a lower-priority device from accessing the Q-bus.

The KDA50, however, leaves a reasonable amount of time before requesting the bus for a successive transfer and thus permits lower-priority DMA devices use of the bus. For performance, this time is not so large that a great many lower-priority devices could be satisfied between two KDA50 requests. Regardless, this KDA50 successive transfer time allowance encourages placement of the KDA50 near, but not at the end of, the bus.

4. The average bandwidth requirements of the device in use

Some intrinsic delay exists in each bus cycle according to how many higher-priority interfaces the bus grant must pass through before reaching the device that wants the bus. Therefore, a more frequently-used device in the configuration should be given a higher priority. Though this consideration is highly application-dependent, it is based on large storage devices connected to the KDA50 being used frequently and would encourage placing the KDA50 further away from the end of the Q-bus.

Overall, the KDA50 should be placed ahead of such devices as the RC25 and RQDX and behind other DMA devices. However, it is important if space limitations force you to place the KDA50 at the very end of the bus (assuming that bus grants are passed to the KDA50).

#### 2.3.3.2 KDA50 Burst Rate Parameter

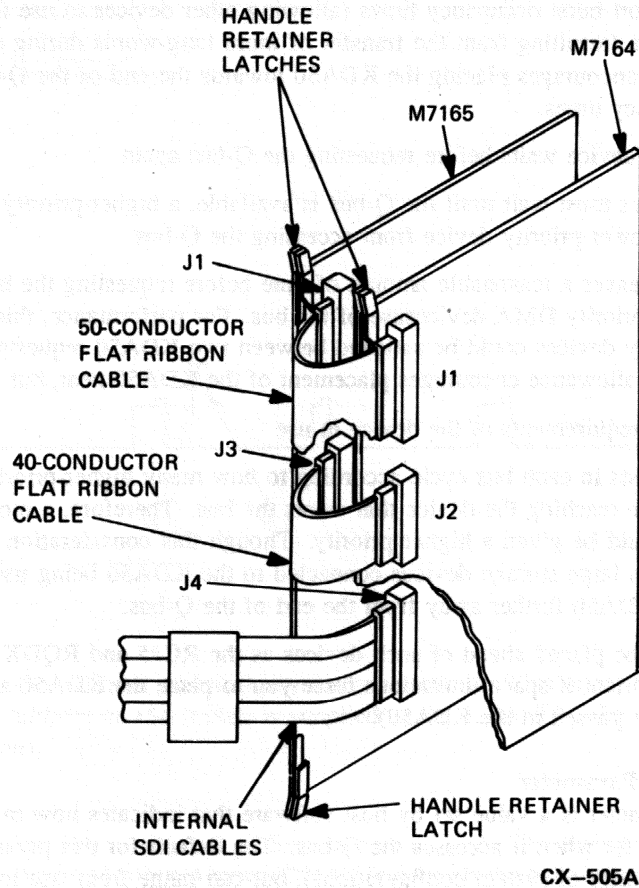
The KDA50 burst rate parameter is a value set by host software that indicates how many long-words (32 bits) the KDA50 attempts to transfer when it accesses the Q-bus. The default for this parameter is four (this value is chosen to suit a large majority of system configurations), but can range from one to eight. By increasing the KDA50 burst parameter to a number greater than one, overall system efficiency increases. However, data-late conditions (on other devices) may become more likely as the parameter is increased. Therefore, the operating system default (four) is recommended.

## INSTALLATION

### 2.3.4 M7164 Intermodule Cable Installation

The KDA50 modules must be interconnected by the two 4-inch long flat ribbon cables shown in Figure 2-7. The outer cable is a 50-conductor flat ribbon cable that connects M7164 (J1) to M7165 (J1). The inner cable is a 40-conductor flat ribbon cable that connects M7164 (J2) to M7165 (J3). Install the two cables on module M7164 first.

Figure 2-7 KDA50 Intermodule Flat Ribbon Cables



### 2.3.5 M7164 Module Installation

At this point, module M7164 should have two intermodule cables attached to it. The I/O page address switches and jumper should be properly set.

Ensure no empty slots are present between options on the backplane. This ensures grant continuity to the KDA50. To accomplish this task, use a grant continuity card, such as M9037.

Insert M7164 into the first of two vacant backplane slots. This slot should be the first available backplane slot of the pair.

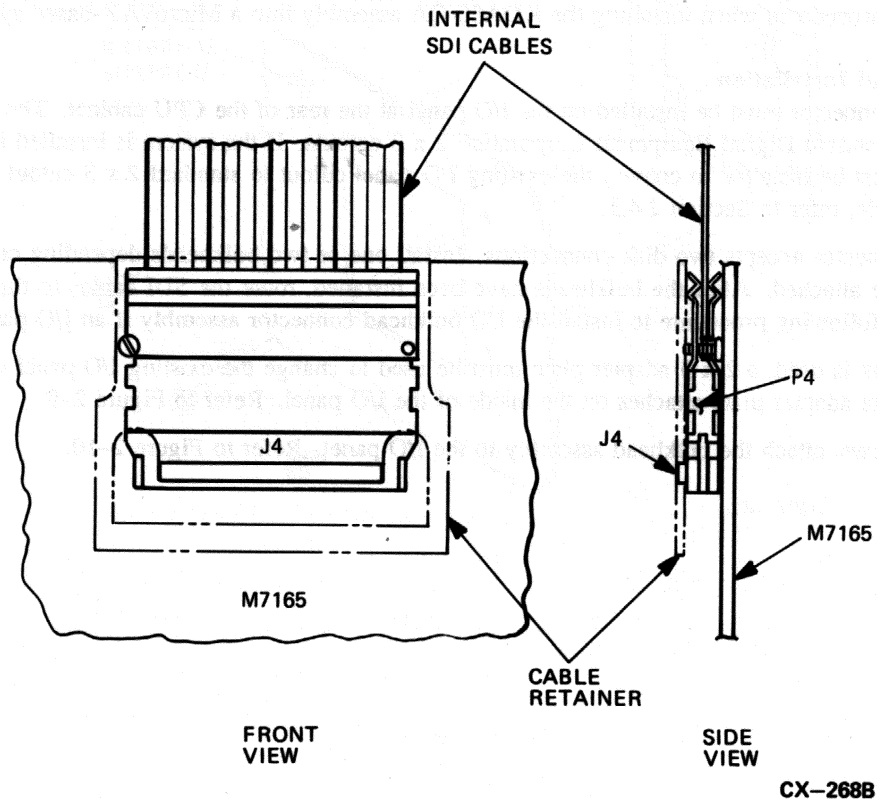
Press M7164 into the backplane and engage the handle retainer latches. Ensure the 50-conductor flat ribbon cable is on top of (not under) the handle retainer latch after the latch is engaged.

### 2.3.6 M7165 SDI Cable Installation and Initial M7165 Insertion

Insert plug P4 of the internal SDI cable assembly into SDI connector J4 on KDA50 module M7165 as shown in Figure 2-8. Slide the cable retainer over connector J4 until the connector protrudes through the plastic cutout. The cable retainer locks the SDI cable in place.

Slide M7165 approximately halfway into the backplane slot.

**Figure 2-8 M7165 SDI Cable Assembly Installation**



### 2.3.7 M7165 Intermodule Cable Installation

Install the 40-conductor flat ribbon cable on module M7165 (J3) and the 50-conductor flat ribbon cable on M7165 (J1) as shown in Figure 2-7.

### 2.3.8 Final M7165 Installation

Press M7165 into the backplane and engage the handle retainer latches. Ensure the 50-conductor flat ribbon cable is on top of the handle retainer latch. Also ensure both modules are now secure and none of the cables are crimped by the latch handles.

## INSTALLATION

### 2.4 INSTALLATION PACKAGES

The following list shows the three installation packages available for the KDA50.

1. KDA50-QA - For microVAX applications
2. KDA50-QB - For PDP-11 based applications
3. KDA50-QC - For BA213 applications

The following sections detail the installation procedures for the KDA50-QA and KDA50-QB. The KDA50-QC is a manufacturing installed option and therefore its installation procedure is not documented in this manual.

#### 2.4.1 KDA50-QA—Standard Installation Package

Use the following procedures when installing the KDA50-QA assembly into a MicroVAX-based system.

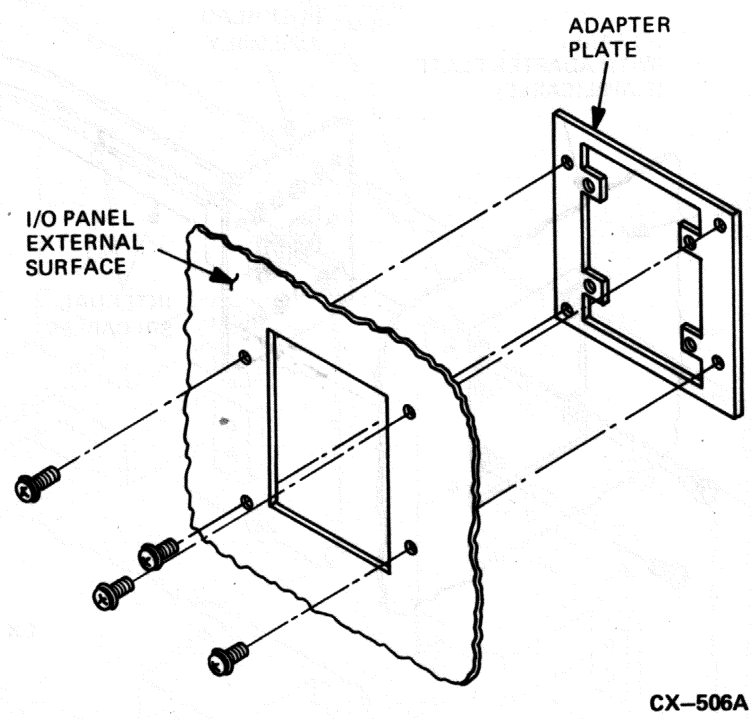
#### 2.4.2 I/O Bulkhead Installation

An I/O bulkhead connector must be installed on the I/O panel at the rear of the CPU cabinet. The connectors are designed to fit in standard Digital Equipment Corporation 2 x 3 cutouts. If the system is installed in a BA11 box, an adapter plate must be installed to convert the existing I/O panel cutout to standard 2 x 3 cutout size. If an I/O panel is not available, refer to Section 2.4.3.

Each bulkhead connector accepts two disk connections. Install one or two bulkheads depending on the number of disk drives to be attached. After the bulkheads have been installed, route the SDI cables to the bulkhead locations. Use the following procedure to install the I/O bulkhead connector assembly if an I/O panel is present:

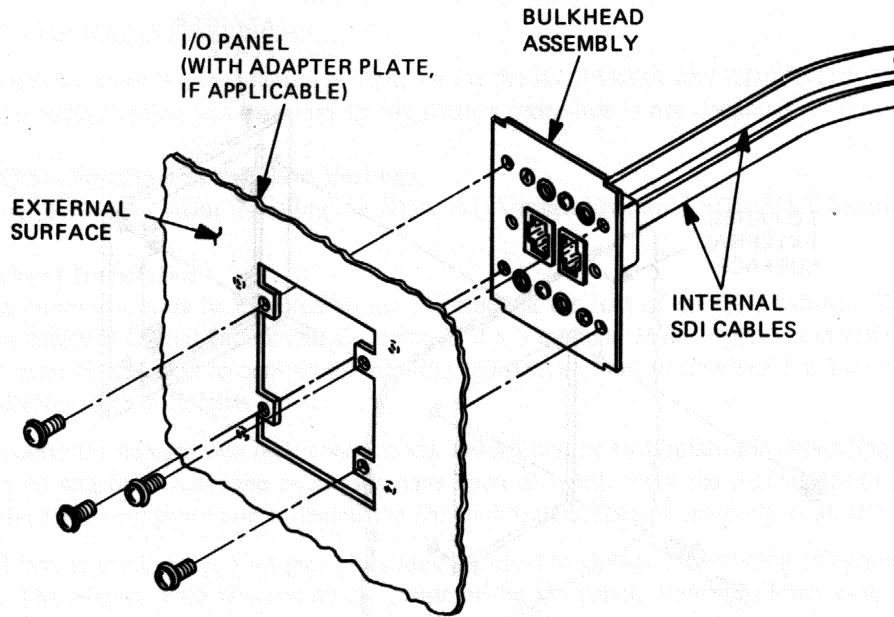
1. If the BA11 box is used, a 2 x 3 adapter plate must be used to change the existing I/O panel cutout to 2 x 3 cutout size. The adapter plate attaches on the inside of the I/O panel. Refer to Figure 2-9.
2. Using four screws, attach the bulkhead assembly to the I/O panel. Refer to Figure 2-10.

Figure 2-9 BA11 2 x 3 Adapter Plate Installation



## INSTALLATION

**Figure 2-10 Bulkhead to I/O Panel Attachment**



CX-507B

### 2.4.2.1 Internal SDI Cables Installation

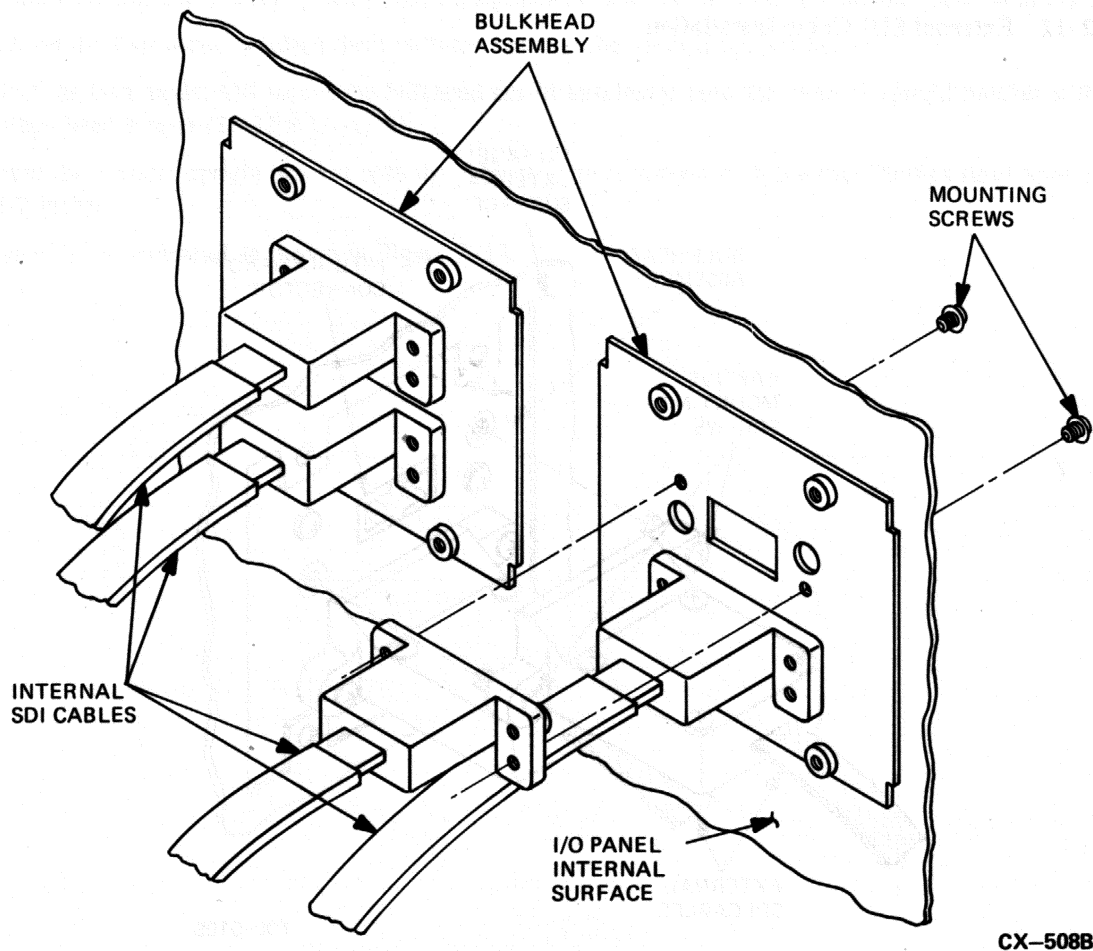
Install the internal SDI cables from the module to the bulkhead assembly as shown in Figure 2-11.

#### NOTE

**The cable ends and connectors are keyed for correct alignment.**

The internal SDI cable assemblies are manufactured so it is unnecessary to secure extra cable. If a cable retractor (used for service access) is present, the internal SDI cable should be attached.



**Figure 2-11 Internal SDI Cable Installation****2.4.2.2 External SDI Cables Installation**

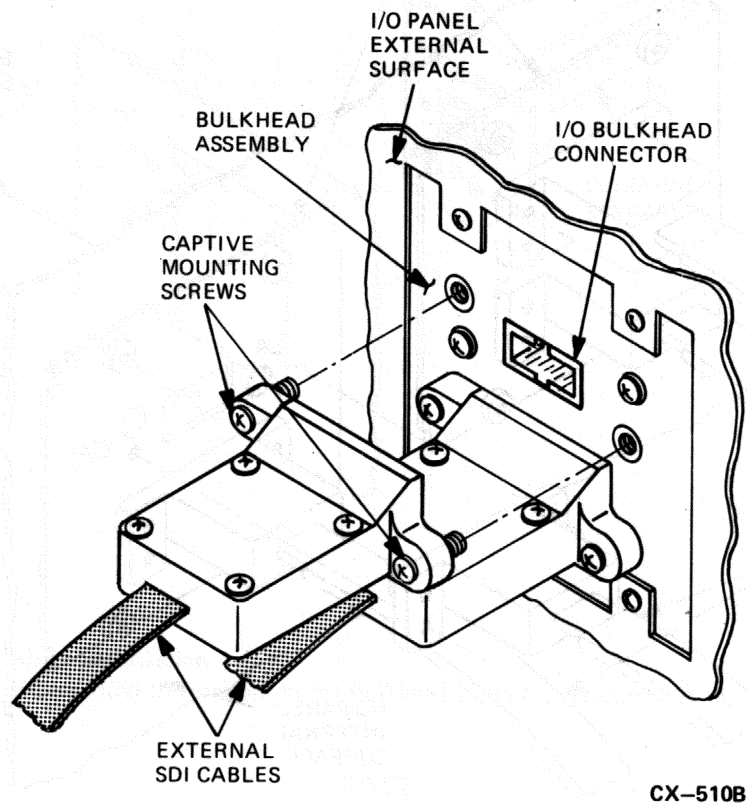
Refer to Figure 2-12 when following this procedure to install external SDI cables:

1. Plug the external SDI cables into the bulkhead assembly.
2. Secure the cables using the screw connections.
3. If the external cables connected to the bulkhead assembly have their natural bend horizontally, use the following procedure:
  - a. Run the cables horizontally to a vertical upright.
  - b. Twist the cables and route them vertically down the upright.

## INSTALLATION

4. If the external cables have their natural bend vertically, secure the cables at the base of the cabinet.
5. If the drives and CPU are in the same cabinet, secure any extra drive cable so it does not interfere with normal operation and service.

Figure 2-12 External SDI Cable Installation



### 2.4.3 KDA50-QB—Alternate Installation Package

Use the following procedure to install the KDA50-QB into a non-MicroVAX based system.

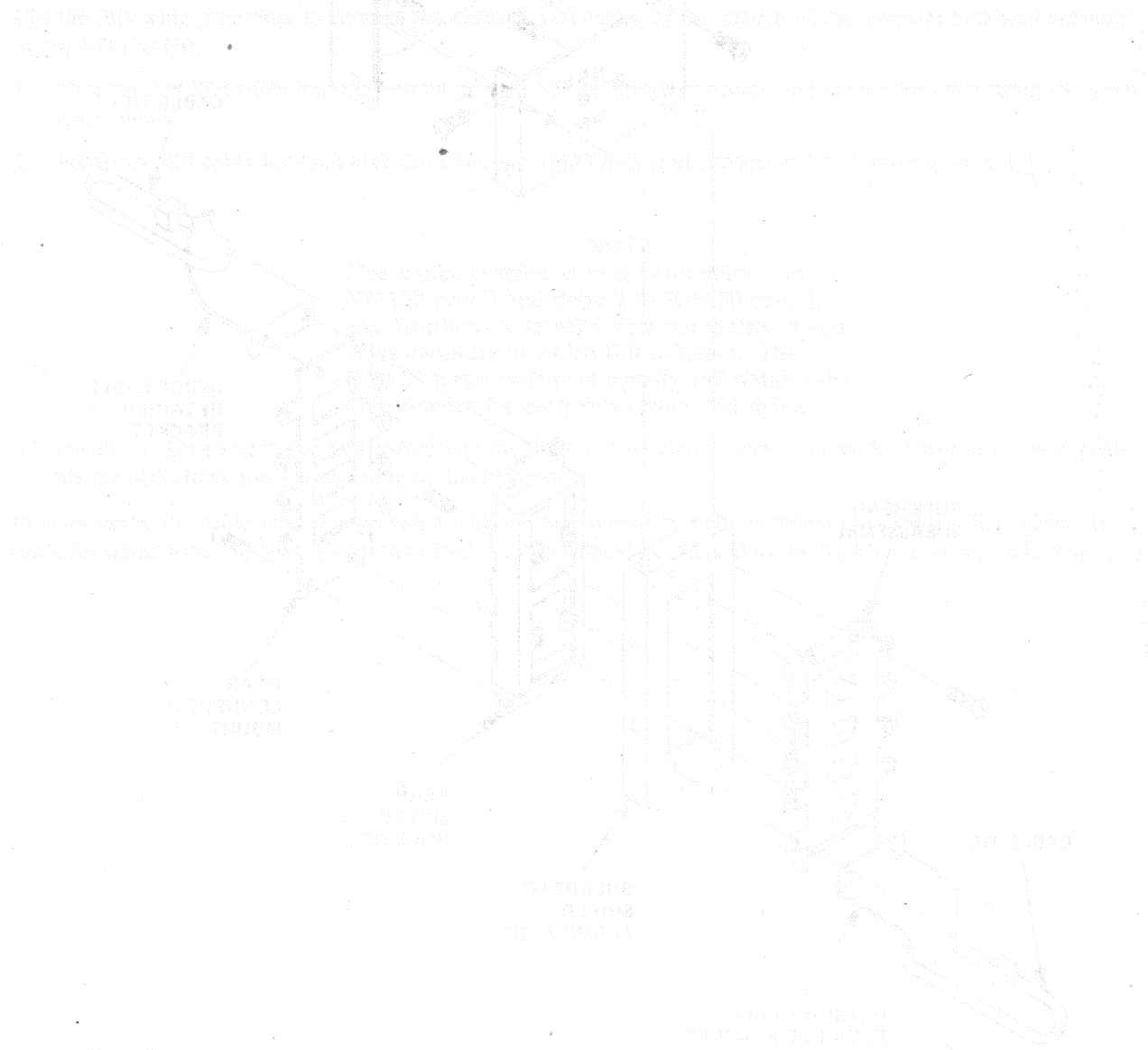
If an I/O panel is not present or if a very long internal SDI cable is required, the KDA50-QB alternate installation package (Part Number KDA50-QB) contains an alternate bulkhead assembly into which internal and external SDI cables can be installed. Procedures for mounting the alternate bulkhead and SDI cabling follow.

If 2 x 3 cutouts are available, use the installation instructions in Section 2.4.2.

**2.4.3.3 Mounting the Alternate Bulkhead Assembly**

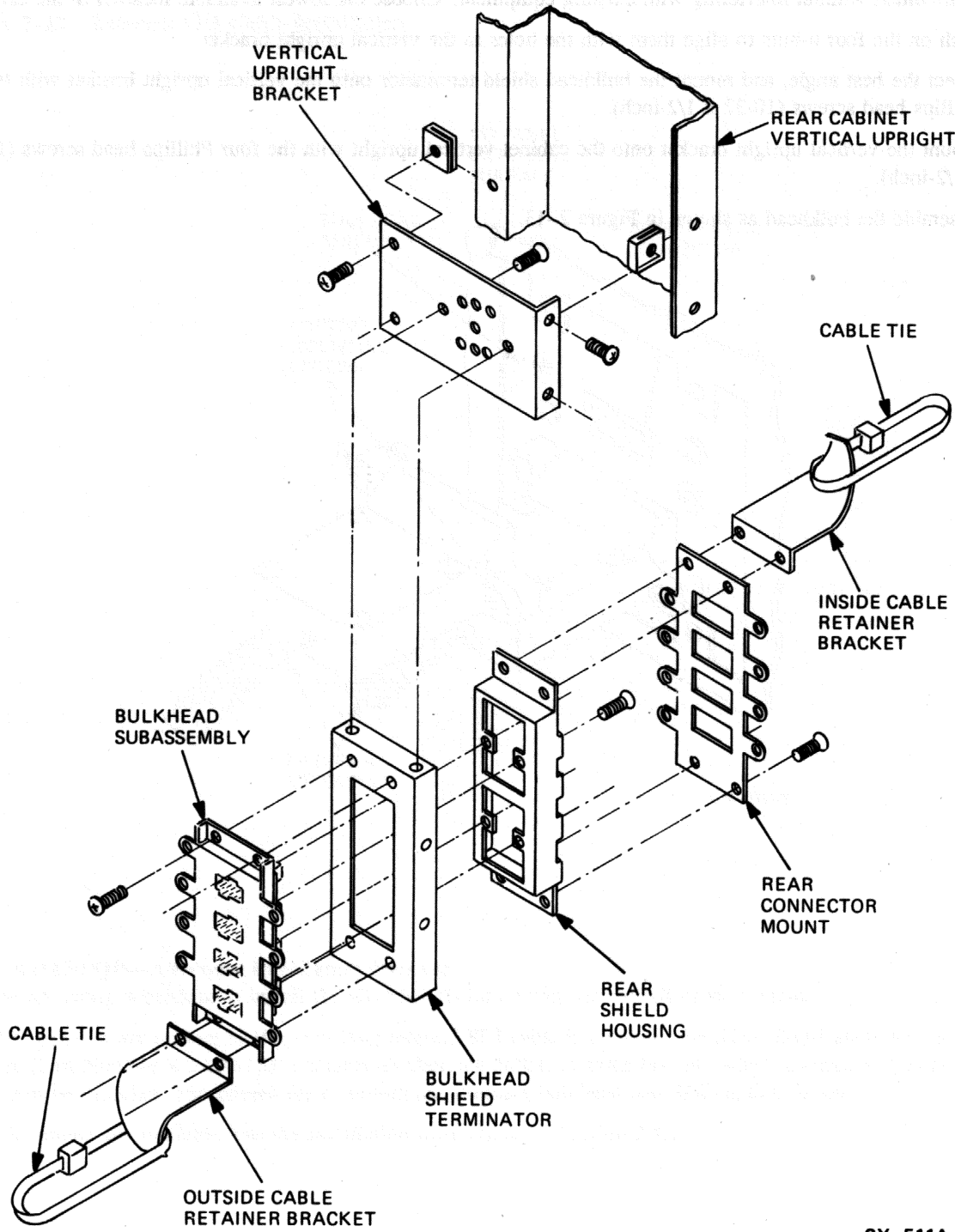
Use the following procedure for installation of the KDA50-QB only if it is impossible to mount the bulkhead assembly to an I/O panel using a KDA50-QA. Refer to Figure Figure 2-13.

1. Select a suitable location on either rear cabinet vertical upright where the alternate bulkhead subassembly can be mounted without interfering with existing equipment. Choose the lowest available location in the cabinet.
2. Push on the four u-nuts to align them with the holes in the vertical upright bracket.
3. Select the best angle, and mount the bulkhead shield terminator onto the vertical upright bracket with two Phillips head screws (10-32 x 1/2-inch).
4. Mount the vertical upright bracket onto the cabinet vertical upright with the four Phillips head screws (10-32 x 1/2-inch).
5. Assemble the bulkhead as shown in Figure 2-13.



**INSTALLATION**

**Figure 2-13 Alternate Bulkhead Assembly**



CX-511A

**2.4.3.4 Alternate Internal SDI Cable Installation**

Use the following procedure to install internal SDI cables into the alternate bulkhead assembly of the KDA50-QB.

**NOTE**

**The cable ends and connectors are keyed for correct alignment.**

1. Connect the internal SDI cables to the bulkhead.
2. Secure the internal SDI cables with cable tie(s) to the inside cable retainer bracket.
3. Secure any extra internal SDI cable(s) to the cabinet vertical upright.

**2.4.3.5 Alternate External SDI Cable Installation**

Use the following procedure to connect the external SDI cables to the outside of the alternate bulkhead assembly of the KDA50-QB.

1. Plug the first SDI cable into the bottom or right I/O bulkhead connector, and secure the cable using the screw connections.
2. Install an SDI cable for each disk drive starting at I/O bulkhead connector 3 and moving toward 0.

**NOTE**

**One useful practice is to connect drive 0 to KDA50 port 0 and drive 1 to KDA50 port 1, etc. However, it actually does not matter which drive connects to which KDA50 port. The KDA50 treats each port equally and obtains the unit number for each drive from that drive.**

3. Install the drive end of the SDI cables into the drive I/O bulkhead connectors as described in the user guide for the disk drive you are attaching to this controller.

In most cases, the cable restraints provided with the unit should be used to secure the exterior SDI cables. If cable restraints have not been given, the exterior cables should be secured to the backframe using cable tie(s).

2.4.2.4. Alternative External SSI Cable Installation  
Use the following procedure to install external SSI cables into the alternate locations specified in the RDA20-02

NOTE

The cable ends and connector are keyed for correct alignment.

1. Connect the internal SSI cables to the backboard.
2. Secure the internal SSI cables with cable ties to the inside cable support brackets.
3. Secure any extra internal SSI cables to the cabinet wall with zip ties.

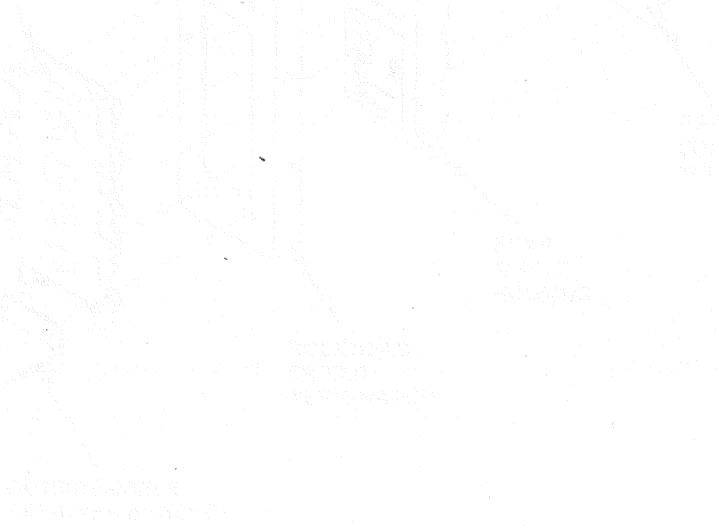
2.4.2.5. Alternative External SSI Cable Installation  
Use the following procedure to install the external SSI cables to the inside of the alternate cabinet enclosure of the RDA20-02.

1. Plug the first SSI cable into the bottom or right (A) backboard connector, and secure the cable using the screw connections.
2. Install an SSI cable for each drive starting at the leftmost connector 1 and working toward the right.

NOTE

The correct pinout is to connect drive 0 to RDA20 port 0 and drive 1 to RDA20 port 1. However, it actually does not matter which drive connects to which RDA20 port. The RDA20 treats each port equally and obtains the drive number for each drive from the drive

3. Plug the drive end of the SSI cable into the drive 00 backboard connector as described in the main guide for the drive you are attaching to this controller.
- In most cases, the cable treatment provided with the unit should be used to secure the external SSI cables. If cable restraints have not been provided, the external cables should be secured to the backboard using cable ties.



## CHAPTER 3

# FIELD ACCEPTANCE TEST PROCEDURE

### 3.1 OVERVIEW

The field acceptance and test procedure for the KDA50 disk subsystem has three parts:

1. The KDA50 disk controller resident diagnostic test.
2. The disk drive field acceptance test (found in the user guide for the disk drive attaching to this controller).
3. The KDA50 host-resident diagnostics (run to complete the third part of this procedure after each subsystem device has been tested separately).

### 3.2 DIAGNOSTICS

Before the KDA50 resident diagnostics are initiated by applying power to the KDA50 disk controller, the CPU should be halted. The four LED indicators on each module should then display a cycling pattern in the LEDs. (Refer to footnote \*\*\* in Table 3-1 and to Figure 2-2, Figure 2-5, and Figure 2-6, which show the location of the four LEDs on each KDA50 module.) The cycling pattern in the LEDs signifies the completion of a successful KDA50 diagnostic test. If, however, the KDA50 LEDs do not display the cycling pattern after power is applied, look at the LED code in Table 3-1 to locate the problem.

Table 3-1 shows LED condition S/B; zero equals LED off and one equals LED on.

Note: 1 = LED ON    0 = LED OFF    x = May be ON or OFF

**Table 3-1 LED Error and Symptom Codes**

M7164 LEDs *	M7165 LEDs *	Error Symptoms	Most Likely Failure
8 4 2 1	8 4 2 1		
0 0 0 1	x x x x	Hex 1; microcode halted in init step 1	M7164
0 0 1 0	0 0 0 0	Hex 2; microcode halted in init step 2	M7164 or software
0 0 1 1	0 0 0 0	Hex 3; microcode halted in init step 3	**
0 1 0 0	0 0 0 0	Hex 4; microcode halted in init step 4, or QBUS timeout error	M7164 or host inactive
B L 0 1 0 I N K	0 0 0 0	Hex 4/5; test complete. Normal display for operating KDA50.	No problem
0 1 1 0 x x x x	x x x x 0 1 1 0	Hex 6; undefined	Undefined

**FIELD ACCEPTANCE TEST PROCEDURE**

**Table 3-1 (Cont.) LED Error and Symptom Codes**

<b>M7164 LEDs *</b> <b>8 4 2 1</b>	<b>M7165 LEDs *</b> <b>8 4 2 1</b>	<b>Error Symptoms</b>	<b>Most Likely Failure</b>
0 1 1 1 x x x x	x x x x 0 1 1 1	Hex 7; undefined	Undefined
1 0 0 0	0 0 0 0	Hex 8; wrap bit 14 set in SA register	M7164 or software
1 0 0 1 0 0 0 0	0 0 0 0 1 0 0 1	Hex 9; board one error	M7164
1 0 1 0 1 0 1 0	0 0 0 0 1 0 1 0	Hex A; board two error	M7165
1 0 1 1 x x x x	x x x x 1 0 1 1	Hex B; undefined	Undefined
x x x x 1 1 0 0	1 1 0 0 x x x x	Hex C; timeout error. Check error code in SA register. Refer to <i>KDA50 Service Manual</i> .	Many causes
1 1 0 1 x x x x	x x x x 1 1 0 1	Hex D; RAM parity error	M7165
1 1 1 0 x x x x	x x x x 1 1 1 0	Hex E; ROM parity error	M7164
1 1 1 1	1 1 1 1	Hex F; sequencer error	M7164
Cycling pattern	Cycling pattern	None	No problem ***
Cycling pattern	Cycling pattern	The cycling pattern continues beyond the start of the initialization process. The KDA50 is not responding to the host CPU.	M7164

\* The bit order significance of the KDA50 LEDs appears to be in reverse order (1, 2, 4, 8) when viewed with the module handles positioned horizontally (chips upward).

\*\* The error code of Hex 3 (0011) is most frequently encountered during installation. The most significant aspect of this display is it describes the point where the KDA50 first attempts to access memory by means of the QBUS. The list following this table includes typical reasons for this error, usually the KDA50 is detecting problems during DMA access.

\*\*\* During a cycling pattern, LEDs begin flashing on the M7164 module, then progress to the M7165 module. The LEDs flash one at a time, starting at the LSB (least significant bit) and progressing through the MSB (most significant bit). The flash goes on and off for approximately a quarter-second, and then repeats at approximately a 4-second rate. However, the pattern is executed so fast that it looks like all the LEDs are flashing at about the same time.



1. QBUS routing in the backplane—Check system documentation to determine how the QBUS is connected through the backplane. Module positions (either dual or quad) not utilized in your configuration may require grant continuity jumpers to ensure proper operation of DMA devices that follow along the QBUS. If another DMA device following the KDA50 in a QBUS sequence works properly, routing problems are not likely.
2. DMA access to memory—The KDA50 may be unable to access memory because of a problem with the memory, processor module, or QBUS expander cables and cards. If another DMA device installed anywhere on the same backplane works properly, this problem is not likely.
3. Grant passing devices—Check the documentation for all other devices on the QBUS preceding the KDA50 in the QBUS sequence. One device (or more) may not properly pass grants to following devices and, if so, the KDA50 must be positioned in advance of any such device(s). If another DMA device following KDA50 in a QBUS sequence works properly, this problem is not likely.
4. M7164 module—If none of the preceding items is the cause of this error code, the M7164 module may be at fault.

The LEDs normally cycle while the KDA50 is waiting for the host to start the initialization process. At this time, the KDA50 responds to the initialization and the cycling pattern stops. This occurs in about four seconds, if the system software is prepared to establish a connection with the KDA50.

When two codes are given for the same error, both indicate the same failure.

### 3.2.1 Drive-Resident Diagnostics

Each disk drive should be tested separately by running the drive-resident diagnostics. The procedure for running these diagnostics is found in the installation instructions for the disk drive attaching to this controller. Perform the drive-field acceptance tests found in the installation procedure, and then perform the subsystem diagnostic procedures in Section 3.2.2.

### 3.2.2 PDP-11 Subsystem Diagnostics

The following paragraphs describe the subsystem diagnostics used with the KDA50 controller when it is used on a PDP-11 CPU with the XXDP+ small or extended monitor. If the diagnostic program reports errors, refer to the *KDA50 Service Manual (EK-KDA5Q-SV)*.

#### NOTE

**If the KDA50 is an add-on to a PDP 11/23-PLUS system, the BEVENT jumper on the KDF11-B microprocessor may need to be removed in order to successfully run diagnostics. Refer to the *PDP 11/23-PLUS System Manual (EK-1T23B-OP)*.**

- CZUDK (KDA50 Disk Drive Formatter) is not a diagnostic. Do not run it unless specifically instructed to do so by Digital Field Service personnel.
- CZUDH (UDA50-A/KDA50 Basic Subsystem Diagnostic) consists of the following three tests:
  - Test 1—Bus Addressing Test
  - Test 2—Disk-Resident Diagnostic Test
  - Test 3—Disk Functional Test
- CZUDI (Disk Exerciser Test)
- CZUDJ (Subsystem Exerciser Test)
  - Test 1—Controller Verification Test
  - Test 2—Subsystem Verification Test
  - Test 3—Subsystem Exerciser

## FIELD ACCEPTANCE TEST PROCEDURE

- CZUDL (Bad Block Replacement Utility)
- CZUDM (Disk Resident Error Log Utility)

Sample hardware and software prompts asked by CZUDH, CZUDI, CZUDJ, and CZUDM are shown in the following examples. In the examples, the symbol in parentheses indicates the response required: D is a decimal number, O is a octal number, L is a logical (Yes/No). The value after the parentheses indicates the default.

### NOTE

**These prompts are subject to change due to diagnostic revisions. Always follow the actual program directions displayed on your terminal. Refer to the software documentation for detailed descriptions, and error messages.**

#### 3.2.2.1 Sample CZUDH Prompts

Sample CZUDH hardware prompts:

CHANGE HW (L) ?

# UNITS (D) 1 ?

UNIT 0

CSR ADDRESS OF CONTROLLER (O) 172150 ?

### NOTE

**CSR=IP.**

VECTOR (O) 154 ?

### NOTE

**This value varies with different system configurations.**

BR LEVEL (D) 5 ?

### NOTE

**The diagnostic ignores the answer and automatically reassigns the appropriate BR level of 4.**

DRIVE NUMBER (D) 0 ?

Sample CZUDH software prompts:

CHANGE SW (L) ?

ENTER MANUAL INTERVENTION MODE IN TEST 2 (L) N ?

**3.2.2.2 Sample CZUDI Prompts**

**Sample CZUDI hardware prompts:**

CHANGE HW (L) ?  
# UNITS (D) 1 ?  
UNIT 0  
CSR ADDRESS OF CONTROLLER (O) 172150 ?  
DRIVE NUMBER (D) 0 ?  
EXERCISE ON CUSTOMER DATA AREA (L) N ?

**Sample CZUDI software prompts:**

CHANGE SW (L) ?  
ENTER MANUAL INTERVENTION MODE FOR SPECIAL DIAGNOSIS (L) N ?  
ERROR LIMIT (D) 32 ?  
READ TRANSFER LIMIT IN MEGABYTES - 0 FOR NO LIMIT (D) 0 ?  
SUPPRESS PRINTING SOFT ERRORS (L) Y ?  
DO INITIAL WRITE ON START (L) Y ?  
ENABLE ERROR LOG (L) N ?

**3.2.2.3 Sample CZUDJ Prompts**

**Sample CZUDJ hardware prompts:**

CHANGE HW (L) ?  
# OF UNITS (D) ?

**NOTE**

**The next three questions are asked for each unit selected**

CSR ADDRESS OF CONTROLLER (O) 172150 ?  
DRIVE # (D) 0 ?  
WRITE ON CUSTOMER DATA AREA (L) N ?

## FIELD ACCEPTANCE TEST PROCEDURE

### Sample CZUDJ software prompts (only asked if you selected Test 3)

CHANGE SW (L) ?  
ENTER MANUAL INTERVENTION MODE (L) N ?  
HARD ERROR LIMIT (D) 1 ?  
EXERCISER TIME LIMIT IN MINUTES (D) 120 ?  
MINUTES BETWEEN STATISTICAL REPORTS (D) 15 ?  
PRINT SOFT ERROR MESSAGES (L) N ?  
DO DATA PATTERN VERIFICATION ON READS (L) N ?  
DO DATA PATTERN VERIFICATION ON WRITES (L) N ?  
USE VARIABLE LENGTH TRANSFERS (L) Y ?  
MAXIMUM TRANSFER SIZE IN BLOCKS (D) 8 ?  
ENABLE ERROR RETRIES (L) Y ?  
ENABLE ECC DATA CORRECTION (L) Y ?  
RANDOMLY ACCESS DRIVE (L) Y ?  
DO SEQUENTIAL WRITE/READ PHASE (L) N ?

#### NOTE

**Sequential Write/Read Phase in the CZUDJ sample prompts was previously known as the Deterministic Phase.**

#### 3.2.2.4 Sample CZUDM Prompts

Sample CZUDM hardware prompts:

CHANGE HW (L) ?  
# UNITS (D) ?  
CRS ADDRESS (O) 172150 ?

Sample CZUDM software prompts:

There are no software questions asked with this utility.

#### 3.2.3 MicroVAX Subsystem Diagnostics

The MicroVAX subsystem diagnostics are executed using the MicroVAX Diagnostic Monitor (MDM). MDM applies to the MicroVAX II system and to the MicroVAX System 3600. It provides a diagnostic operating system and supports functional testing of a MicroVAX processor and the peripherals.

MDM and the associated diagnostic programs are contained on floppy diskettes or a tape, depending on which boot device you are using (RX50 disk drive or TK50 tape drive). These floppy diskettes and/or tape are provided with the MicroVAX system. The floppy diskettes consist of:

1. Diskettes 1 and 2 containing:
  - Boot program
2. Several diskettes containing:
  - MDM
  - CPU diagnostics
  - Memory diagnostics

3. A diagnostic floppy diskette containing the various diagnostic programs for the different peripheral devices on your system.
4. An additional diagnostic floppy diskette containing the remainder of the peripheral device diagnostics.

The KDA50 diagnostic program consists of the following tests:

1. Wrap mode—Verifies data patterns written to the controller SA register can be looped back to the host.
2. Interrupt test—Ensures the KDA50 generates interrupts correctly.
3. Controller RAM test—Ensures the KDA50 RAM is free of typical RAM memory errors.
4. Subsystem functional test—Verifies proper operation of the disk subsystem for various drives attached to the KDA50.
5. Exerciser—Performs inputs and outputs to the various drives attached to the KDA50 to detect possible intermittent failures in the subsystem.

### 3.2.4 Running MDM

After powerup or reset, the console device displays the following message:

```
KA630-A.Vx.x
```

```
Performing normal system tests.
```

```
7..6..5..4..3..
```

```
Tests completed.
```

```
Loading system software.
```

```
2..0..1..
```

The device then proceeds through the system startup procedure and displays the following system prompt :

```
>>>
```

At the prompt, boot the MDM diagnostic software using the provided boot device and media. The console then displays:

```
2..1..0..
```

```
VAXELN V2.x-xx
```

```
MicroVAX Maintenance System - Release Vx.xx
```

```
Confidential Diagnostic Software
```

```
Property of
```

```
Digital Equipment Corporation
```

```
Use authorized only pursuant to a valid right-to-use license.
```

```
The current date and time is xx-xxx-xxxx xx:xx:xx:xx
```

```
Press the Return Key to continue
```

```
or enter the new date and time, then press the Return Key.
```

```
[DD-MMM-YYYY-HH:MM]:
```

The system prompts for input and, in the case of an RX50 boot device, instructs when to change floppy disks.

## FIELD ACCEPTANCE TEST PROCEDURE

Once the the diagnostics are loaded in system memory, the console device displays the following message:

The system is ready for testing.

Press the RETURN key to continue. >

At this point, load scratch media in both floppy disk drives and continue (press the RETURN key). The MDM main menu appears as follows:

### MAIN MENU

- 1 - Test the System
- 2 - Display System Configuration and Devices
- 3 - Display the Utilities Menu
- 4 - Display the Service Menu
- 5 - Exit MicroVAX Maintenance System

Type the number; then press the RETURN key. >

If your menu choice is:

1. Test the System Refer to Section 3.2.4.1.
2. Display System Configuration and Devices refer to Section 3.2.4.2.
3. Display the Utilities Menu Refer to Section 3.2.4.3.
4. Display the Service Menu Refer to Section 3.2.4.4.
5. Exit MicroVAX Maintenance System Refer to Section 3.2.4.5.

#### 3.2.4.1 Choice 1—Test the System

The system test performs the functional tests for each MicroVAX device. The exerciser test follows. MDM prompts you to either return to the main menu or begin the test.

Once the test starts, the console device displays the name of the device under test and the test result. After the functional tests have completed, the exerciser test begins. Again, the device under test is displayed on the console device along with its test status. Choice 1 (Test the System) is complete when the exerciser portion is completed.

#### 3.2.4.2 Choice 2—Display System Configuration and Devices

Selecting Choice 2 causes MDM to list the system devices. That is, a KDA50 with two disk drives (RA60 and RA81, for example) produces the following listing in the display:

```
KDA50-QA ... Q-bus SDI disk controller.  
  KDA50-Q - REV MC=x HW=x  
    RA60 ... Removable media disk drive.  
    RA81 ... Fixed media disk drive.
```

#### NOTE

In the designation KDA50-QA, the "A" denotes the first KDA50 on the system.

If more than one KDA50 exists on the system, the second KDA50 would be designated KDA50-QB, and so forth. This is also true for other devices on the system.

**3.2.4.3 Choice 3—Display the Utilities Menu**

If Choice 3 is attempted, the following message appears:

To use this function you must purchase the MicroVAX Maintenance Kit, which includes the appropriate license.

**3.2.4.4 Choice 4—Display the Service Menu**

If Choice 4 is attempted, the following message appears:

To use this function you must purchase the MicroVAX Maintenance Kit, which includes the appropriate license.

If the user selects choice 4 from the main menu and the MDM maintenance kit has been installed, the following menu appears:

MAIN MENU  
SERVICE MENU

CAUTION: This is intended for use by qualified service personnel only. Misuse of the commands could destroy data.

- 1 - Set test and message parameters
- 2 - Exercise system continuously.
- 3 - Display the device menu
- 4 - Enter system commands

Type the number; then press the RETURN key, or type 0 and press the RETURN key to return to the Main Menu.>

To select the KDA specific diagnostics, the user enters choice 3. This will invoke the device menu. The menu displayed will depend on the specific system configuration. A sample menu is shown below:

MAIN MENU  
SERVICE MENU  
DEVICE MENU

This menu lets you select a device for testing.

- 1 - MEMA - MicroVAX/rtVAX memory system
- 2 - KDA50QA - Q-bus SDI disk controller
- 3 - RQDAX - Winchester ddisk controller

Type the number; then press the RETURN key, or type 0 and press the RETURN key to return to the Service Menu.

If at this point the user selects the menu number that corresponds to the KDA50QA device, in this example choice 2, the following menu is displayed:

MAIN MENU  
SERVICE MENU  
DEVICE MENU  
KDA50QA - Q-bus SDI disk controller MENU

Testing is ENABLED

- 1 - ENABLE/disable testing for device
- 2 - Perform all functional test



## FIELD ACCEPTANCE TEST PROCEDURE

- 3 - Perform the exerciser test
- 4 - Display the device utilities menu

Type the number; then press the RETURN key,  
or type 0 and press the RETURN key to return to the  
Device Menu.

The following explains menu selections:

1. Selecting this choice enables the user to toggle the device from the enable to disabled state.
2. Selecting this choice, causes the system to execute all of the KDA functional tests.
3. Selecting this choice, causes the system to execute the KDA exerciser.
4. Selecting this choice, causes the system to display the device utility menu:

MAIN MENU  
SERVICE MENU  
DEVICE MENU  
KDA50QA - Q-bus SDI disk controller MENU  
UTILITY PROGRAMS AND TESTS MENU

Utility selections are:

- 1 - MSCP Level Subsystem Exerciser.(Test 5).
- 2 - Basic Functional Test (Tests 1-3)
- 3 - Drive Internal Error Log Utility.
- 4 - RA Disk Drive Formatter

Type the number; then press the RETURN key,  
or type 0 and press the RETURN to return to the previous Menu.>

1. The MSCP Level Subsystem exerciser exercises the controller and any attached drives in a similar manner to the exerciser in the previous menu. The only difference is this exerciser allows the user to also perform write testing. If write testing is selected, the user's data should be backed up prior to the testing.
2. The Basic Functional Tests (Tests 1-4) uses a DUP program that is loaded into the controller to provide improved fault isolation on the controller and disk drives.
3. The Drive Resident Error Log Utility (DRELU) displays error log entries from drives which support internal error logging. For the RA80, RA81 and RA82 only 16 bytes of hex data will be displayed. For the RA60, no error log is implemented.
4. The DUP RA Disk Drive Formatter formats any RA series disk connected to the KDA50-Q controller. The formatter program is actually a DUP program that is loaded into into the controller and run.

### 3.2.4.5 Choice 5—Exit MicroVAX Maintenance System

Choice 5 brings you back to the system (>>>) prompt.

## 3.3 SYSTEM AND SOFTWARE CONSIDERATIONS

The following paragraphs describe system and software considerations important when using a KDA50 disk controller.

### 3.3.1 System Clock or Timer

Some aspects of both diagnostic and/or functional usage of a KDA50 depend upon the ability of the host processor to time out an operation. Thus, clock interrupts should be enabled. Check host processor documentation for the appropriate instructions.



### 3.3.2 Error Logs

The KDA50 returns information to the operating system for inclusion into an error log. This information may be specific to the operation of the KDA50, its attached drives, or other parts of the system (such as host processor, memory, software, etc.), which may be important in diagnosing problem sources. Error logging should be enabled in the operating system. For further directions, refer to the system documentation.

Some reports contained in the error log may represent information on the configuration or operation of your system and do not represent the occurrence of an actual error condition. Examples are:

- Completion of the KDA50 initialization sequence.
- Attention messages pertaining to the availability of a disk drive (which may be the result of changing a drive unit number).

### 3.3.3 Drive Numbering

DSA/SDI drives connected to the KDA50 are given a unit number ranging from 0 to 254. However, some operating systems may only support the range from 0 to 7. Consult operating system documentation for appropriate range capability and drive documentation for assigning unit numbers.

The unit numbers assigned to drives attached to a KDA50 do not imply any priority. All drives are treated equally by the KDA50. The only requirement for unit number assignments is to avoid the duplication of unit numbers on two different drives. If these numbers are duplicated, the KDA50 does not permit drive access. This situation may be corrected by changing either (or both) of the duplicated numbers.

Unit numbers can be changed at the drive, although this is recommended only when the intended drive is not online to the KDA50 (not mounted by the operating system).

3.2.1. *Reverse Engineering*

The KLEVER system is a multi-processor system for the control of a robot arm. The system is based on the concept of the KLEVER, the control data, or other parts of the system, being processed by the robot arm. The system is based on the concept of the KLEVER, the control data, or other parts of the system, being processed by the robot arm. The system is based on the concept of the KLEVER, the control data, or other parts of the system, being processed by the robot arm.

3.2.2. *Reverse Engineering*

The KLEVER system is a multi-processor system for the control of a robot arm. The system is based on the concept of the KLEVER, the control data, or other parts of the system, being processed by the robot arm. The system is based on the concept of the KLEVER, the control data, or other parts of the system, being processed by the robot arm.

3.2.3. *Reverse Engineering*

The KLEVER system is a multi-processor system for the control of a robot arm. The system is based on the concept of the KLEVER, the control data, or other parts of the system, being processed by the robot arm. The system is based on the concept of the KLEVER, the control data, or other parts of the system, being processed by the robot arm.

3.2.4. *Reverse Engineering*

The KLEVER system is a multi-processor system for the control of a robot arm. The system is based on the concept of the KLEVER, the control data, or other parts of the system, being processed by the robot arm. The system is based on the concept of the KLEVER, the control data, or other parts of the system, being processed by the robot arm.

3.2.5. *Reverse Engineering*

The KLEVER system is a multi-processor system for the control of a robot arm. The system is based on the concept of the KLEVER, the control data, or other parts of the system, being processed by the robot arm. The system is based on the concept of the KLEVER, the control data, or other parts of the system, being processed by the robot arm.

## CHAPTER 4

### KDA50 PROGRAMMER INFORMATION

#### 4.1 KDA50 SPECIFIC PROGRAMMING INFORMATION

The following information is necessary in order to write software for the KDA50:

- The default address of the KDA50 IP register is 172150 (octal).
- The address of the KDA50 SA register is the IP address plus two.
- The KDA50 supports interrupt vector address set by the host. A typical vector address of 154 (octal) is supplied to the KDA50 from the host software. However, this value varies with different system configurations.
- The KDA50 has a command limit value of 21. This includes 20 MSCP commands and 1 IMMEDIATE-ONLY command.
- The KDA50 supports a DMA burst value of 1 to 8 long-words (32 bits). The operating system default burst value is recommended.
- The KDA50 supports only 512-byte disk formats.
- The KDA50 supports both MSCP and the diagnostic and utilities protocols (DUP).
- The diagnostic option capabilities available on the KDA50 are purge/poll and wrap.
- The KDA50 supports maintenance read and maintenance write to and from the KDA50 RAM.
- The KDA50 supports last fail log packets.
- The KDA50 has automatic support for block mode memories.

#### NOTE

Some of the items in the preceding list are host-dependent and may or may not apply, depending on the host.

# RESEARCH REPORT

The research objectives of this study are to investigate the effects of the proposed system on the performance of the system. The study is divided into two main parts: a theoretical analysis and an experimental evaluation. The theoretical analysis is based on the principles of the system and the results of previous research. The experimental evaluation is based on the results of a series of experiments conducted under controlled conditions. The results of the theoretical analysis and the experimental evaluation are presented in the following sections. The theoretical analysis shows that the proposed system is capable of achieving the desired performance objectives. The experimental evaluation shows that the proposed system is capable of achieving the desired performance objectives under a wide range of conditions. The results of the theoretical analysis and the experimental evaluation are consistent with each other, indicating that the proposed system is capable of achieving the desired performance objectives.

## CONCLUSION

The results of this study indicate that the proposed system is capable of achieving the desired performance objectives. The theoretical analysis and the experimental evaluation both show that the proposed system is capable of achieving the desired performance objectives under a wide range of conditions. The results of the theoretical analysis and the experimental evaluation are consistent with each other, indicating that the proposed system is capable of achieving the desired performance objectives.

## Index

### B

- BEVENT jumper, 3-3
- Burst rate parameter
  - description of, 2-9
  - when considering device placement, 2-9
- Bus tuning, 2-8

### C

- Checklist
  - for installation, 2-3
- Clock interrupt, 3-10
- CSR address, 2-3
- Customer service, 1-5

### D

- Device positioning, 2-8
- Diagnostic
  - drive resident, 3-3
  - MicroVAX subsystem, 3-6
  - PDP-11 subsystem, 3-3
    - CZUDH, 3-3
      - hardware prompts, 3-4
      - software prompts, 3-4
    - CZUDI, 3-3
      - hardware prompts, 3-5
      - software prompts, 3-5
    - CZUDJ, 3-3
      - hardware prompts, 3-5
      - software prompts, 3-6
    - CZUDK, 3-3
    - CZUDM
      - hardware prompts, 3-6
- Digital Storage Architecture
  - see DSA
- Drive numbers, 3-11
- DSA Description, 1-1
- Dual microprocessor, 1-3

### E

- Error recovery
  - ECC, 1-3
    - performed by the drive control stream, 1-4
    - performed by the Q-bus control stream, 1-4
  - revectoring, 1-1

### F

- Floating addresses, 2-3

### G

- Grant continuity, 2-10

### I

- I/O page address, 2-3
- Installation
  - of modules, 2-3
- Installation checklist, 2-3
- Installation of intermodule cables, 2-10
- Installation overview, 2-2

### K

- KDA50
  - general description, 1-1

### M

- Mass Storage Control Protocol
  - see MSCP
- MDM, 3-6
- Microcode
  - drive control stream general functions, 1-4
  - Q-bus control stream general functions, 1-3
- MicroVAX diagnostic monitor
  - see MDM
- MSCP, 1-1

### P

- Priority
  - of DMA devices, 2-8
  - of non-DMA devices, 2-8
- Processor module
  - list of general functions, 1-3

### Q

- Q22/CD backplane, 2-4
- Q22/Q22 backplane, 2-4

**INDEX**

**Q-bus tuning, 2-8**

**R**

**Related documentation, 1-6**

**S**

**SA register address, 2-3**

**SDI module**

list of general functions, 1-3

**Sequencers, 1-3**

**Service documentation, 1-6**

**Status and address**

see SA

**System clock, 3-10**

**T**

**Testing 3-1**

**Time out, 3-10**

**U**

**Unit numbers, 3-11**

**V**

**Vector address, 2-8**

